



# AK5354

## Low Power 20bit $\Delta\Sigma$ ADC with PGA

**FEATURES**

The AK5354 is a low voltage 20bit A/D converter for digital audio system. The AK5354 also includes Analog input PGA, therefore is suitable for microphone application and etc. As digital power supply of the AK5354 corresponds to 1.8V, the interface with microprocessor can operate at low voltage. Analog signal input of the AK5354 is single-ended, therefore, any external filters are not required. As the package is 16pin TSSOP, the AK5354 is a suitable for minimizing system.

**FEATURES**

1. Resolution : 20bits
2. Recording Functions
  - 2-Stereo Inputs Selector
  - Analog Input PGA
  - Monaural Mixing
  - Digital HPF for DC-offset cancellation ( $f_c=3.4\text{Hz}@f_s=44.1\text{kHz}$ )
3. ADC Characteristics
  - Input Level :  $1.5\text{Vpp}@V_A=2.5\text{V}$  (=  $0.6 \times V_A$ )
  - S/(N+D) : 84dB
  - DR, S/N : 89dB
4. 3-wire Serial Control I/F
5. Master Clock : 256fs/384fs
6. Audio Data Format : MSB First, 2's compliment
  - 20bit MSB justified or I<sup>2</sup>S
8. Power Supply
  - $V_A$  : 2.1 ~ 3.3V (typ. 2.5V)
  - $V_D$  : 1.8 ~ 3.3V (typ. 2.5V)
9. Power Supply Current
  - IPGA + ADC : 7mA
10.  $T_a = -40 \sim 85^\circ\text{C}$
11. Package : 16pin TSSOP

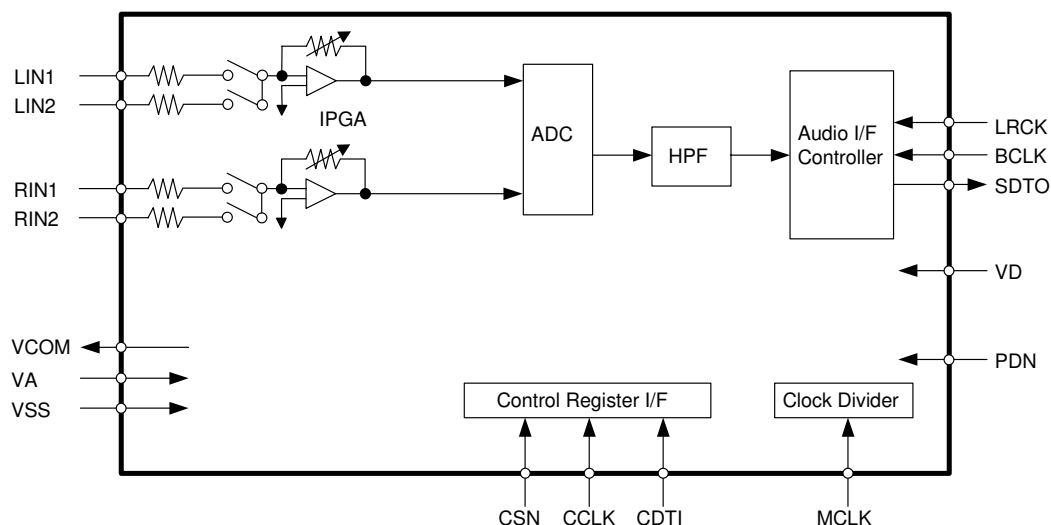

■ Ordering Guide

AK5354VT  
AKD5354

-40 ~ +85°C  
Evaluation Board for AK5354

16pin TSSOP (0.65mm pitch)

■ Pin Layout

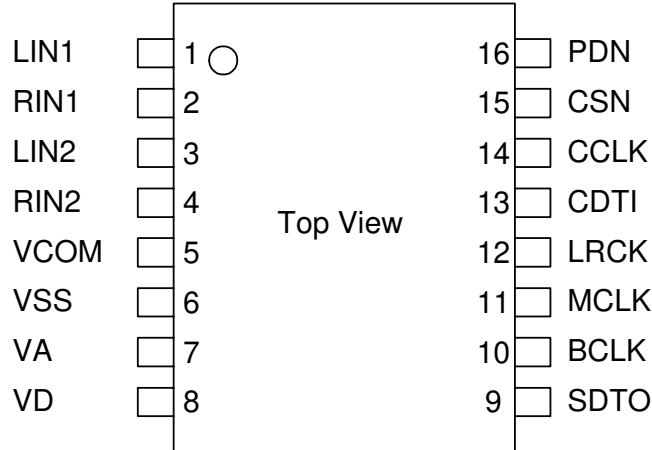

**PIN/FUNCTION**

No.	Pin Name	I/O	Function
1	LIN1	I	Lch #1 Input Pin
2	RIN1	I	Rch #1 Input Pin
3	LIN2	I	Lch #2 Input Pin
4	RIN2	I	Rch #2 Input Pin
5	VCOM	O	ADC Common Voltage Output Pin
6	VSS	-	Ground Pin
7	VA	-	Analog Power Supply Pin, +2.5V
8	VD	-	Digital Power Supply Pin, +2.5V
9	SDTO	O	Audio Serial Data Output Pin
10	BCLK	I	Audio Serial Data Clock Pin
11	MCLK	I	Master Clock Input Pin
12	LRCK	I	Input/Output Channel Clock Pin
13	CDTI	I	Control Data Input Pin
14	CCLK	I	Control Clock Input Pin
15	CSN	I	Chip Select Pin
16	PDN	I	Reset & Power Down Pin “L” : Reset & Power down “H” : Normal operation

Note: All digital input pins should not be left floating.

<b>ABSOLUTE MAXIMUM RATINGS</b>
---------------------------------

(VSS=0V; Note 1)

Parameter		Symbol	min	max	Units
Power Supply	Analog	VA	-0.3	4.6	V
	Digital	VD	-0.3	4.6	V
Input Current (Any Pin Except Supplies)		IIN	-	±10	mA
Analog Input Voltage (LIN2-1, RIN2-1 pins)		VINA	-0.3	VA+0.3	V
Digital Input Voltage		VIND	-0.3	VD+0.3	V
Ambient Temperature (power applied)		Ta	-40	85	°C
Storage Temperature		Tstg	-65	150	°C

Note: 1. All voltages with respect to ground.

WARNING: Operation at or beyond these limits may results in permanent damage to the device.  
Normal operation is not guaranteed at these extremes.

<b>RECOMMENDED OPERATING CONDITIONS</b>
---

(VSS=0V; Note 1)

Parameter		Symbol	min	typ	max	Units
Power Supply	Analog (VA pin)	VA	2.1	2.5	3.3	V
	Digital (VD pin)	VD	1.8	2.5	VA	V

Note: 1. All voltages with respect to ground.

WARNING: AKM assumes no responsibility for the usage beyond the conditions in this data sheet.

<b>ANALOG CHARACTERISTICS</b>
-------------------------------

(Ta=25°C; VA, VD=2.5V; fs=44.1kHz; Signal Frequency=1kHz; Measurement frequency=10Hz ~ 20kHz; unless otherwise specified)

Parameter	min	typ	max	Units	
Resolution			20	bits	
<b>Input PGA Characteristics (IPGA):</b>					
Input Voltage (LIN1, LIN2, RIN1, RIN2) (Note 2)	1.35	1.5	1.65	Vpp	
Input Impedance	6.3	9	15	kΩ	
Step Width	+28dB ~ -8dB	0.1	0.5	1	dB
	-8dB ~ -16dB	0.1	1	2	dB
	-16dB ~ -32dB	0.1	2	4	dB
	-32dB ~ -40dB	-	2	-	dB
	-40dB ~ -52dB	-	4	-	dB
<b>ADC Analog Input Characteristics: (Note 3)</b>					
S/(N+D) (-0.5dBFS Input)	74	84		dB	
D-Range (EIAJ)	82	89		dB	
S/N (EIAJ)	82	89		dB	
Interchannel Isolation	90	100		dB	
Interchannel Gain Mismatch		0.2	0.5	dB	
<b>Power Supplies</b>					
Power Supply Current: VA+VD					
Normal Operation (PDN="H")					
IPGA+AD (PM0=1, PM1=1)		7	10	mA	
Power Down (PDN="L") (Note 4)		10	100	μA	

Note: 2. Analog input voltage (full-scale voltage: IPGA = 0dB) scale with VREF. (IPGA = ADC = 0.6 x VREF)

Note: 3. ADC is input from LIN1/RIN1 or LIN2/RIN2 and it measures included in IPGA. The value of IPGA is set 0dB. Internal HPF cancels the offset of IPGA and ADC.

Note: 4. In case of power-down mode, all digital input pins including clocks pins (MCLK, BCLK and LRCK) are held VD or VSS. PDN pin is held VSS.

<b>FILTER CHARACTERISTICS</b>
-------------------------------

(Ta=25°C; VA=2.1 ~ 3.3V, VD=1.8 ~ 3.3; fs=44.1kHz)

Parameter	Symbol	min	typ	max	Units	
<b>ADC Digital Filter (Decimation LPF):</b>						
Passband (Note 5)	±0.1dB -1.0dB -3.0dB	PB	0	17.4	kHz	
					20.0	kHz
					21.1	kHz
Stopband (Note 5)	SB	27.0			kHz	
Passband Ripple	PR			±0.1	dB	
Stopband Attenuation	SA	65			dB	
Group Delay (Note 6)	GD		17.0		1/fs	
Group Delay Distortion	ΔGD		0		μs	
<b>ADC Digital Filter (HPF):</b>						
Frequency Response (Note 5)	-3dB -0.5dB -0.1dB	FR		3.4	Hz	
					10	Hz
					22	Hz

Note:5. The passband and stopband frequencies scale with fs (sampling frequency).

For examples, PB=0.454 x fs(@ADC: -1.0dB), PB=0.454 x fs(@DAC: -0.1dB).

Note: 6. The calculating delay time which occurred by digital filtering. This time is from the input of analog signal to setting the 20bit data of both channels to the output register for ADC and include group delay of HPF.

<b>DC CHARACTERISTICS</b>
---------------------------

(Ta=25°C; VA=2.1 ~ 3.3V, VD=1.8 ~ 3.3V)

Parameter	Symbol	min	Typ	max	Units
High-Level Input Voltage	VIH	75%VD	-	-	V
Low-Level Input Voltage	VIL	-	-	25%VD	V
High-Level Output Voltage (Iout=-80μA)	VOH	VD-0.4	-	-	V
Low-Level Output Voltage (Iout=80μA)	VOL	-	-	0.4	V
Input Leakage Current	Iin	-	-	± 10	μA

<b>SWITCHING CHARACTERISTICS</b>
----------------------------------

(Ta=25°C; VA=2.1 ~ 3.3V, VD=1.8 ~ 3.3V; CL=20pF)

Parameter	Symbol	min	typ	max	Units
<b>Control Clock Frequency</b>					
<b>Master Clock (MCLK)</b> 256fs: Frequency Pulse Width Low Pulse Width High 384fs: Frequency Pulse Width Low Pulse Width High <b>Channel Clock (LRCK)</b> Frequency Duty Cycle	fCLK	2.048	11.2896	12.8	MHz
	tCLKL	28			ns
	tCLKH	28			ns
	fCLK	3.072	16.9344	19.2	MHz
	tCLKL	23			ns
	tCLKH	23			ns
	fs	8	44.1	50	kHz
		45		55	%
<b>Audio Interface Timing</b>					
BCLK Period	tBLK	312.5			ns
BCLK Pulse Width Low	tBLKL	130			ns
Pulse Width High	tBLKH	130			ns
BCLK “↓” to LRCK	tBLR	-tBLKH+50		tBLKL-50	ns
LRCK Edge to SDTO (MSB)	tDLR			80	ns
BCLK “↓” to SDTO	tDSS			80	ns
<b>Control Interface Timing</b>					
CCLK Period	tCCK	200(Note 7)			ns
CCLK Pulse Width Low	tCCKL	80			ns
Pulse Width High	tCCKH	80			ns
CDATA Setup Time	tCDS	50			ns
CDATA Hold Time	tCDH	50			ns
CSN “H” Time	tCSW	150(Note 7)			ns
CSN “↓” to CCLK “↑”	tCSS	50(Note 7)			ns
CCLK “↑” to CSN “↑”	tCSH	50			ns
<b>Reset / Calibration Timing</b>					
PDN Pulse Width	tPW	150			ns
PDN “↑” to SDTO (Note 8)	tPWV		4128		1/fs

Note: 7. fs ≥ 19.6kHz.

In the case of fs < 19.6kHz, these three parameters must meet a relationship of (tCSW + tCSS + 7 × tCCK) > 1/(32 × fs) in addition to these specifications.

For example, When tCCK=200ns and tCSS=50ns at fs=8kHz, tCSW(min) is 2457ns. When tCSW=150ns and tCSS=50ns fs=8kHz, tCCK(min) is 530ns.

Note: 8. These cycles are the numbers of LRCK rising from PDN pin rising.

■ Timing Diagram

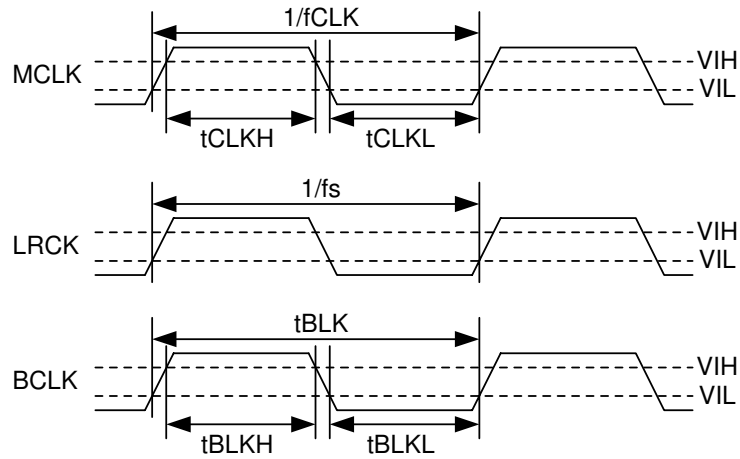

Figure 1. Clock Timing

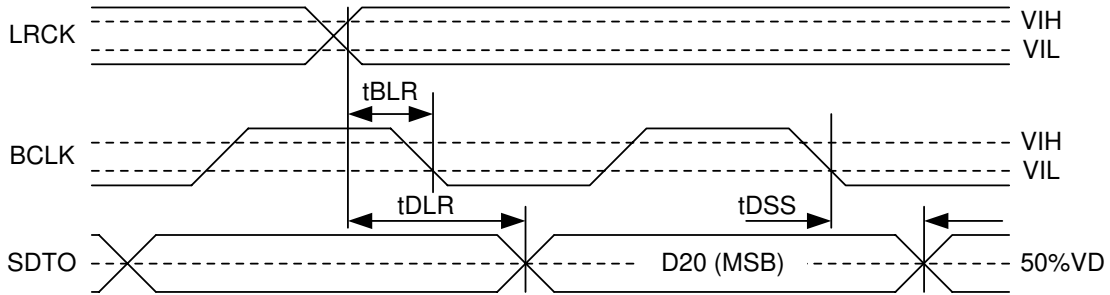

Figure 2. Audio Data Input/Output Timing (Audio I/F = No.0)

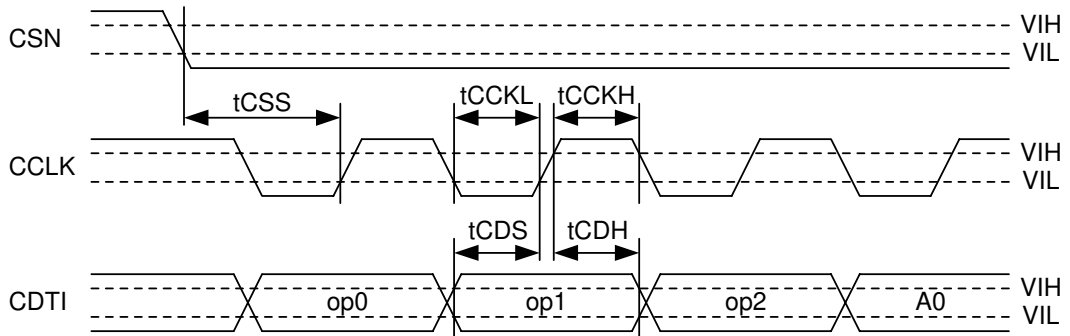

Figure 3. WRITE Command Input Timing

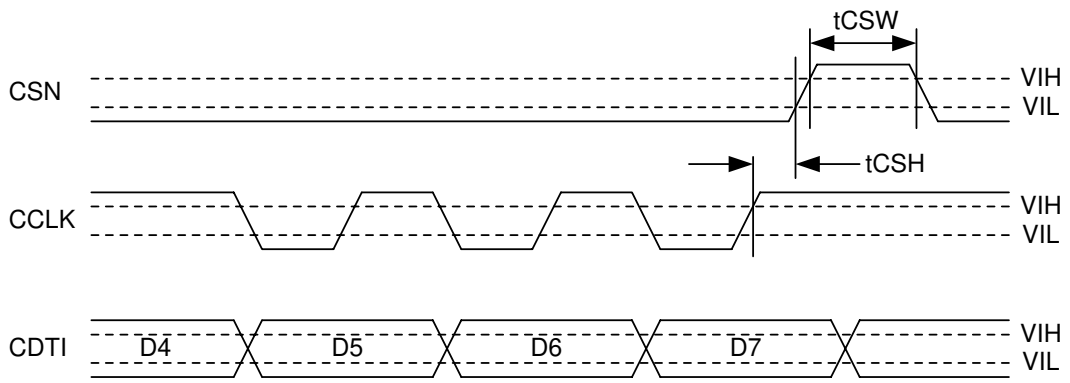

Figure 4. WRITE Data Input Timing

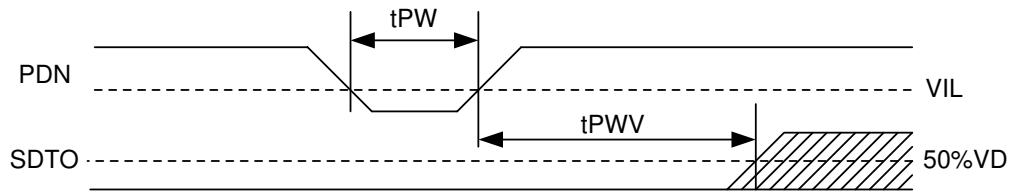

Figure 5. Reset Timing



**OPERATION OVERVIEW**

■ **System Clock**

The clocks that are required to operate are MCLK (256fs/384fs), LRCK (fs) and BCLK (40fs~). The master clock (MCLK) should be synchronized with LRCK but the phase is free of care. The frequency of MCLK can be input 256fs or 384fs. When the 384fs is input, the internal master clock is divided into 2/3 automatically.

\*fs is sampling frequency.

All external clocks (MCLK, BCLK and LRCK) should always be present whenever ADC is in operation. If these clocks are not provided, the AK5354 may draw excess current and it is not possible to operate properly because utilizes dynamic refreshed internally. If the external clocks are not present, the AK5354 should be in the power-down mode.

■ **Audio Data I/F Format**

Using SDTO, BCLK and LRCK pins are connected to external system. Audio data format has two kinds of mode, the data format is MSB-first, 2's compliment. Setting by DIF bit. The initial value is DIF = "0".

No.	DIF bit	SDTO (ADC)	LRCK	BCLK
0	0	20bit MSB justified	Lch: "H", Rch: "L"	≥ 40fs
1	1	I <sup>2</sup> S Compatible	Lch: "L", Rch: "H"	≥ 40fs

Table 1. Audio Data Format

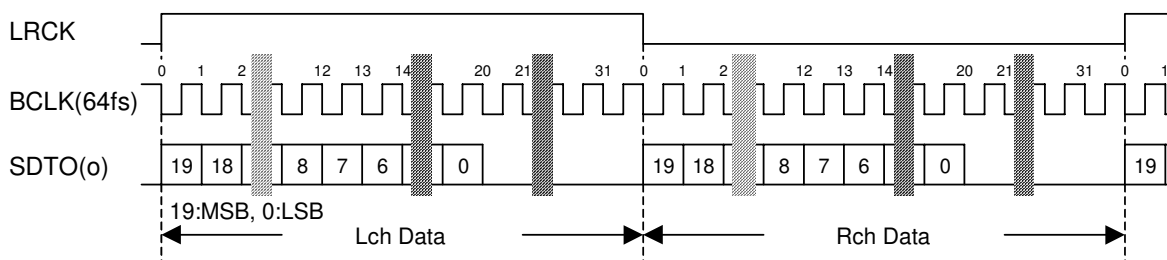

Figure 6. Audio Data Format (No.0)

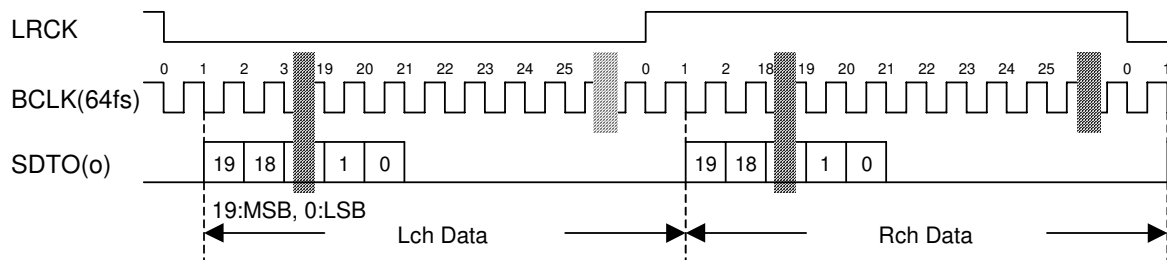

Figure 7. Audio Data Format (No.1)

■ **Digital High Pass Filter**

The AK5354 has a Digital High Pass Filter (HPF) to cancel DC-offset in ADC and IPGA. The cut-off frequency of the HPF is 3.4Hz at fs=44.1kHz. It also scales with the sampling frequency (fs). And digital HPF can be selected by ON/OFF of HPF bit.

## ■ System Reset & Offset Calibration

The AK5354 should be reset once by bringing PDN pin “L” after power-up. The control register values are initialized by PDN “L”.

Offset calibration starts by PDN pin “L” to “H”. It takes 4128/fs to offset calibration cycle. During offset calibration, the ADC digital data outputs of both channels are forced to a 2’s complement “0”. Output data of settles data equivalent for analog input signal after offset calibration. IPGA is set MUTE during offset calibration and after offset calibration.

As a normal offset calibration may not be executed, nothing write at address 01H during offset calibration.

When offset calibration is executed once, the calibration memory is held even if each block is powered down (PM0 = “0” or PM1 = “0”) by power management bits.

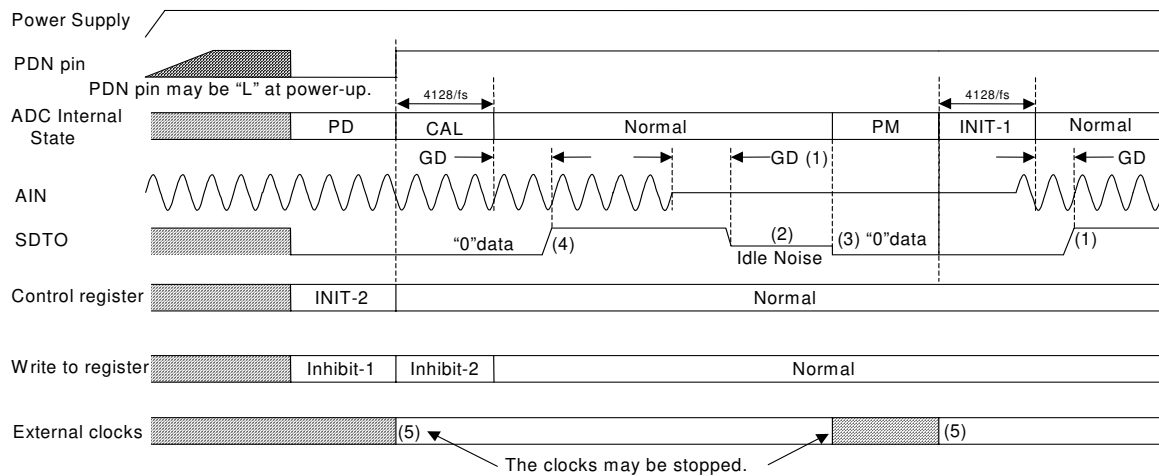

Figure 8. Power up / Power down Timing Example

- PD: Power-down state. ADC is output “0”.
- PM: Power-down state by Power Management bit. ADC is output “0”.
- CAL: During offset calibration cycle. IPGA is set MUTE state.
- INIT-1: Initializing all control registers.
- Inhibit-1: Inhibits writing to all control registers.
- Inhibit-2: Enable writing to control registers except address 01H.

Note: See “Register Definitions” about the condition of each register.

- (1). Digital output corresponding to analog input and analog output corresponding to digital input have the group delay (GD). Output signal gradually comes to settle to input signal during a group delay.
- (2). If the analog signal does not be input, digital outputs have the offset to op-amp of input and some offset error of a internal ADC.
- (3). ADC output is “0” at power down.
- (4). This figure shows that MUTE of IPGA is canceled during offset calibration. If MUTE of IPGA is canceled, SDTO outputs Idle Noise.
- (5). When the external clocks (MCLK, BCLK and LRCK) are stopped, the AK5354 should be in the power down (PDN pin = “L” or PM1 bit = “0”) mode.

■ Timing of Control Register

The internal registers are written by the 3-wire  $\mu$ P interface pins: CSN, CCLK, CDTI. These data are included by Op-code (3bit), Address (LSB-first, 5bit) and Control data (LSB-first, 8bit). A side of transmitted data is output to each bit by “ $\downarrow$ ” of CCLK, a side of receiving data is input by “ $\uparrow$ ” of CCLK. Writing of data becomes effective by “ $\uparrow$ ” of CSN. CSN should be held to “H” at no access.

Address except 00H ~ 03H inhibits control of writing. And CCLK always need 16 edges of “ $\uparrow$ ” during CSN = “L”.

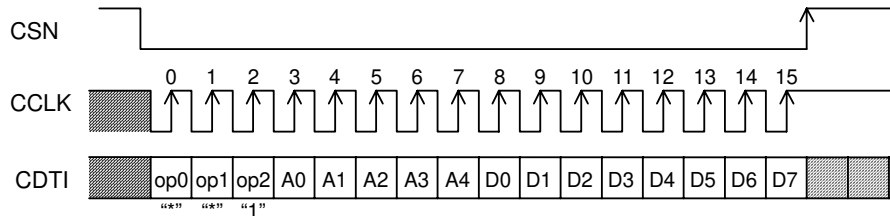

op0-op2: Op code (Fixed to “111:WRITE”)  
 A0-A4: Register Address  
 D0-D7: Control data

Figure 9. Control Data Timing

■ Register Map

Addr	Register Name	D7	D6	D5	D4	D3	D2	D1	D0
00H	Input Select	0	0	0	HPF	RIN2	RIN1	LIN2	LIN1
01H	Mode Control 1	0	0	0	0	0	0	PM1	PM0
02H	Mode Control 2	MONO1	MONO0	ZTM1	ZTM0	0	0	DIF	0
03H	Input Analog PGA Control	ZEIP	IPGA6	IPGA5	IPGA4	IPGA3	IPGA2	IPGA1	IPGA0

All registers are reset at PDN = “L”, then inhibits writing to all registers.

## ■ Register Definition

### Input Select

Addr	Register Name	D7	D6	D5	D4	D3	D2	D1	D0
00H	Input Select	0	0	0	HPF	RIN2	RIN1	LIN2	LIN1
	RESET	0	0	0	0	0	1	0	1

HPF: Select ON/OFF of the digital HPF. (0: ON, 1: OFF)

LIN2-1: Select ON/OFF of Lch input. (0: OFF, 1: ON)

RIN2-1: Select ON/OFF of Rch input. (0: OFF, 1: ON)

### Mode Control 1

Addr	Register Name	D7	D6	D5	D4	D3	D2	D1	D0
01H	Mode Control 1	0	0	0	0	0	0	PM1	PM0
	RESET	0	0	0	0	0	0	1	1

PM1-0: Power Management (0: Power down, 1: Power up)

PM0: Power control of IPGA

PM1: Power control of ADC

When PDN pin goes “L”, all circuit in the AK5354 can be powered-down in no relation to PM1-0. When PM1-0 goes all “0”, all circuit in the AK5354 can be also powered-down. However, the contents of control registers are held.

In case of PM1 = “1”, MCLK is not stopped.

**Mode Control 2**

Addr	Register Name	D7	D6	D5	D4	D3	D2	D1	D0
02H	Mode Control 2	MONO1	MONO0	ZTM1	ZTM0	0	0	DIF	0
	RESET	0	0	1	1	0	0	0	0

MONO1-0: Monaural Mixing  
 00: Stereo (RESET)  
 01: (L+R)/2  
 10: LL  
 11: RR

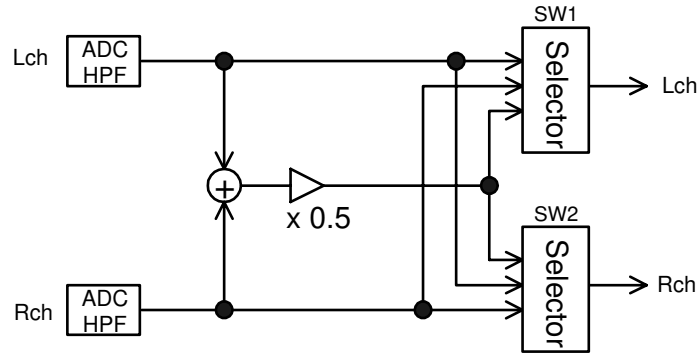

Figure 10. Monaural mixing block

Mode	SW1	SW2	MONO1	MONO0
Stereo Recording	Lch	Rch	0	0
Monaural Recording Stereo Input	(L+R)/2	(L+R)/2	0	1
Monaural Recording Lch Input	Lch	Lch	1	0
Monaural Recording Rch Input	Rch	Rch	1	1

Table 2. Monaural Mode Setting

ZTM1-0: Setting of Zero Crossing Timeout for IPGA  
 00: 256/fs  
 01: 512/fs  
 10: 1024/fs  
 11: 2048/fs (RESET)

DIF: Select Digital Interface Format

No.	DIF bit	SDTO(ADC)	LRCK	BCLK	Reset
0	0	20bit MSB justified	Lch: "H", Rch: "L"	≥ 40fs	
1	1	I <sup>2</sup> S Compatible	Lch: "L", Rch: "H"	≥ 40fs	

Table 3. Audio Data Format

Inhibits writing at PM1 = "0".

**Input Analog PGA Control**

Addr	Register Name	D7	D6	D5	D4	D3	D2	D1	D0
03H	Input Analog PGA Control	ZEIP	IPGA6	IPGA5	IPGA4	IPGA3	IPGA2	IPGA1	IPGA0
	RESET	0	00H (MUTE)						

**ZEIP:** Select IPGA zero crossing operation (0: Disable, 1: Enable)  
 Writing to IPGA value at ZEIP = "1", IPGA value of L/R channels changes by zero crossing detection or timeout independently.

In the timeout cycle, it is possible to set in ZTM1-0 bit.  
 When ZTM1-0 is "11", timeout cycle is 2048/fs = 46.4ms (@fs=44.kHz).  
 When ZEIP is "0", IPGA changes immediately. When PM1 is "0", ZEIP is ignored and IPGA does the operation which is the same as the case of ZEIP = "0".

**IPGA6-0:** Input Analog PGA. 97 levels. 00H=MUTE.  
 ON/OFF of zero crossing detection can be controlled by ZEIP bit.  
 Inhibits writing at PM0 = "0".

DATA	GAIN(dB)	Step	Level
60H	+28.0	0.5dB	73
5FH	+27.5		
5EH	+27.0		
•	•		
28H	+0.0		
27H	-0.5		
•	•		
19H	-7.5	1dB	8
18H	-8.0		
17H	-9.0		
16H	-10.0		
•	•		
11H	-15.0	2dB	12
10H	-16.0		
0FH	-18.0		
0EH	-20.0		
•	•	4dB	3
05H	-38.0		
04H	-40.0		
03H	-44.0		
02H	-48.0		
01H	-52.0		
00H	MUTE		1

Table 4. Input Gain Setting

- About zero crossing operation

Comparator for zero crossing detection in the AK5354 has offset. Therefore, it is a possible that IPGA value is changed by zero crossing timeout as zero crossing detection does not occur by a little offset of comparator.

For example, when Lch and Rch are in the state of IPGA = 30H, both channels are set to IPGA = 31H. And then the only Lch completed zero crossing, Rch is waiting for zero crossing detection, zero crossing counter is reset when IPGA is newly written 32H, zero crossing operation starts toward IPGA = 32H in state Lch = 31H, Rch = 30H. Internal IPGA value in the AK5354 has the registers of L/R channels independently, according to change IPGA value independently, IPGA value of L/R channels may become a difference in level.

Therefore, if IPGA is written before zero crossing detection on zero crossing timeout, IPGA is keeping the same value. When IPGA is finished by normal zero crossing timeout on IPGA value of L/R channels does not give a difference in level, the change of IPGA should be written after zero crossing timeout cycle and over.

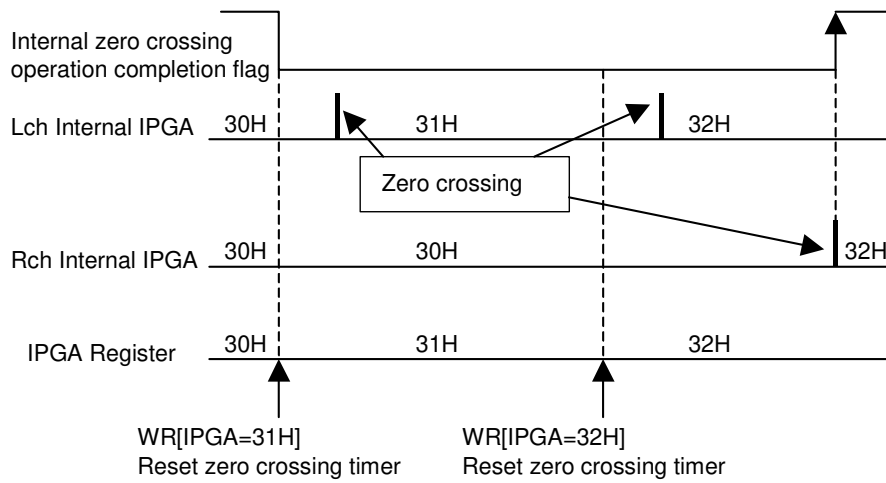

Figure 11. About Zero Crossing Operation

**SYSTEM DESIGN**

Figure 12 shows the system connection diagram. An evaluation board [AKD5354] is available which demonstrates application circuit, optimum layout, power supply arrangements and measurement results.

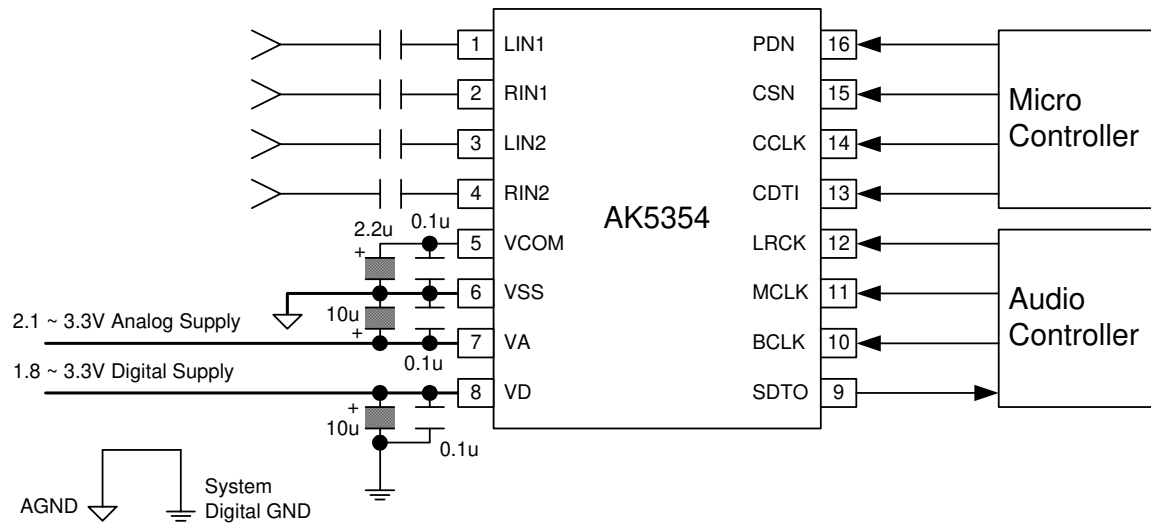

Figure 12. System Connection Diagram Example

Notes:

- Electrolytic capacitor value of VCOM depends on low frequency noise of supply voltage.



### 1. Grounding and Power Supply Decoupling

The AK5354 requires careful attention to power supply and grounding arrangements. VA is usually supplied from analog supply in system. VD is a power supply pin to interface with the external ICs and is supplied from digital supply in system. VSS of the AK5354 should be connected to analog ground plane. System analog ground and digital ground should be connected together near to where the supplies are brought onto the printed circuit board. Decoupling capacitors should be as near to the AK5354 as possible, with the small value ceramic capacitor being the nearest.

### 2. Voltage Reference

The input to VA Voltage sets the analog input range. A 0.1 $\mu$ F ceramic capacitor and a 10 $\mu$ F electrolytic capacitor is connected to VA and VSS pins, normally. VCOM is a signal ground of this chip. An electrolytic 2.2 $\mu$ F in parallel with a 0.1 $\mu$ F ceramic capacitor attached to these pins eliminates the effects of high frequency noise. No load current may be drawn from VCOM pin. All signals, especially clock, should be kept away from the VA, VD and VCOM pins in order to avoid unwanted coupling into the AK5354.

### 3. Analog Inputs

The analog inputs are single-ended and the input resistance 9k $\Omega$  (typ). The input signal range scales with nominally 0.6 x VA Vpp (typ) centered in the internal common voltage (typ. 0.45 x VA). Usually, the input signal cuts DC with a capacitor. The cut-off frequency is  $f_c=(1/2\pi RC)$ . The AK5354 can accept input voltages from VSS to VA. The ADC output data format is 2's complement. The DC offset including ADC own DC offset removed by the internal HPF ( $f_c=3.4\text{Hz}@f_s=44.1\text{kHz}$ ).

**PACKAGE**

16pin TSSOP (Unit: mm)

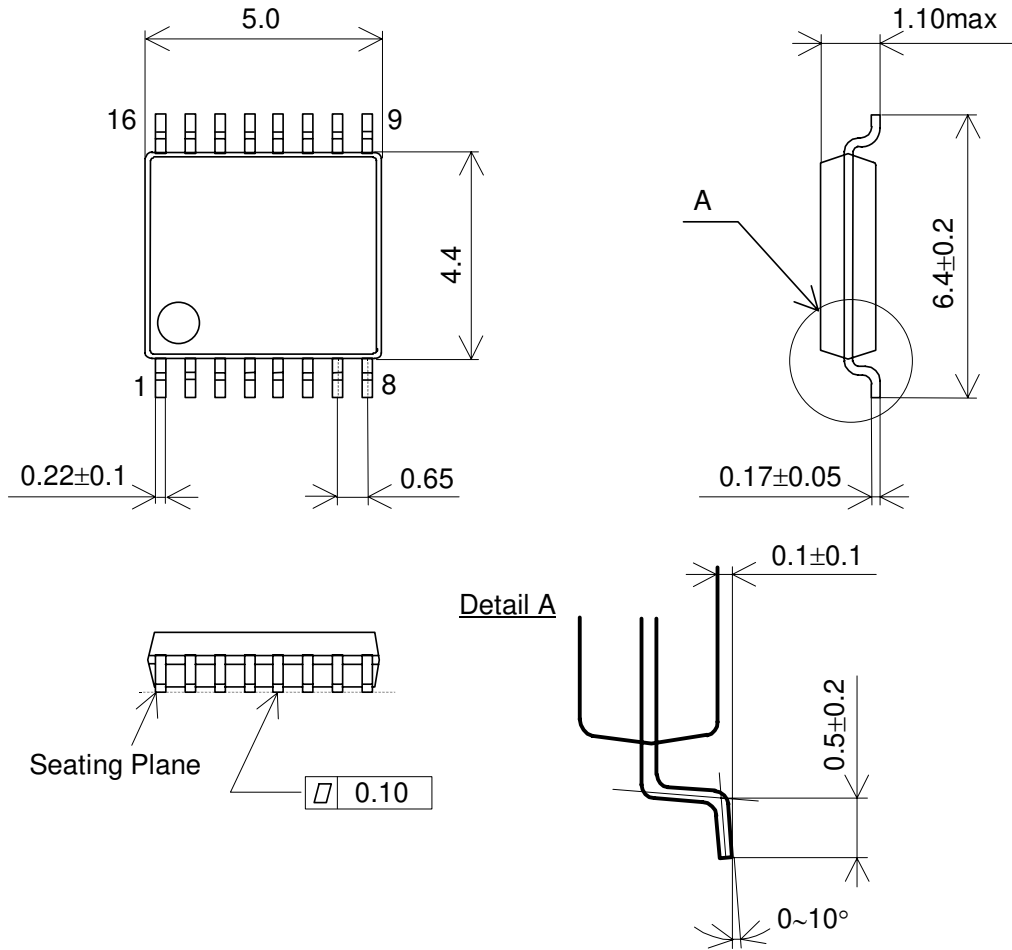

■ Package & Lead frame material

Package molding compound:	Epoxy
Lead frame material:	Cu
Lead frame surface treatment:	Solder plate

<b>MARKING</b>
----------------

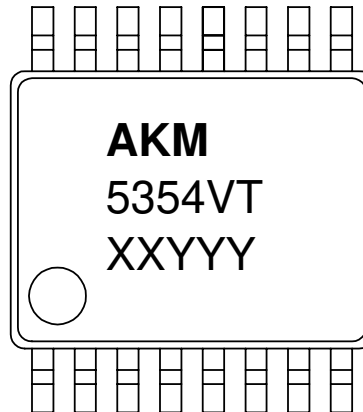

- 1) Pin #1 indication
- 2) Date Code : XXYYYY (5 digits)  
     XX : lot#  
     YYY : Date Code
- 3) Marketing Code : 5354VT
- 4) Asahi Kasei Logo

**IMPORTANT NOTICE**

- These products and their specifications are subject to change without notice. Before considering any use or application, consult the Asahi Kasei Microsystems Co., Ltd. (AKM) sales office or authorized distributor concerning their current status.
- AKM assumes no liability for infringement of any patent, intellectual property, or other right in the application or use of any information contained herein.
- Any export of these products, or devices or systems containing them, may require an export license or other official approval under the law and regulations of the country of export pertaining to customs and tariffs, currency exchange, or strategic materials.
- AKM products are neither intended nor authorized for use as critical components in any safety, life support, or other hazard related device or system, and AKM assumes no responsibility relating to any such use, except with the express written consent of the Representative Director of AKM. As used here:
  - a. A hazard related device or system is one designed or intended for life support or maintenance of safety or for applications in medicine, aerospace, nuclear energy, or other fields, in which its failure to function or perform may reasonably be expected to result in loss of life or in significant injury or damage to person or property.
  - b. A critical component is one whose failure to function or perform may reasonably be expected to result, whether directly or indirectly, in the loss of the safety or effectiveness of the device or system containing it, and which must therefore meet very high standards of performance and reliability.
- It is the responsibility of the buyer or distributor of an AKM product who distributes, disposes of, or otherwise places the product with a third party to notify that party in advance of the above content and conditions, and the buyer or distributor agrees to assume any and all responsibility and liability for and hold AKM harmless from any and all claims arising from the use of said product in the absence of such notification.