

SMP

Straight Plug PCB  
Smooth Bore

**19S145-400L5**

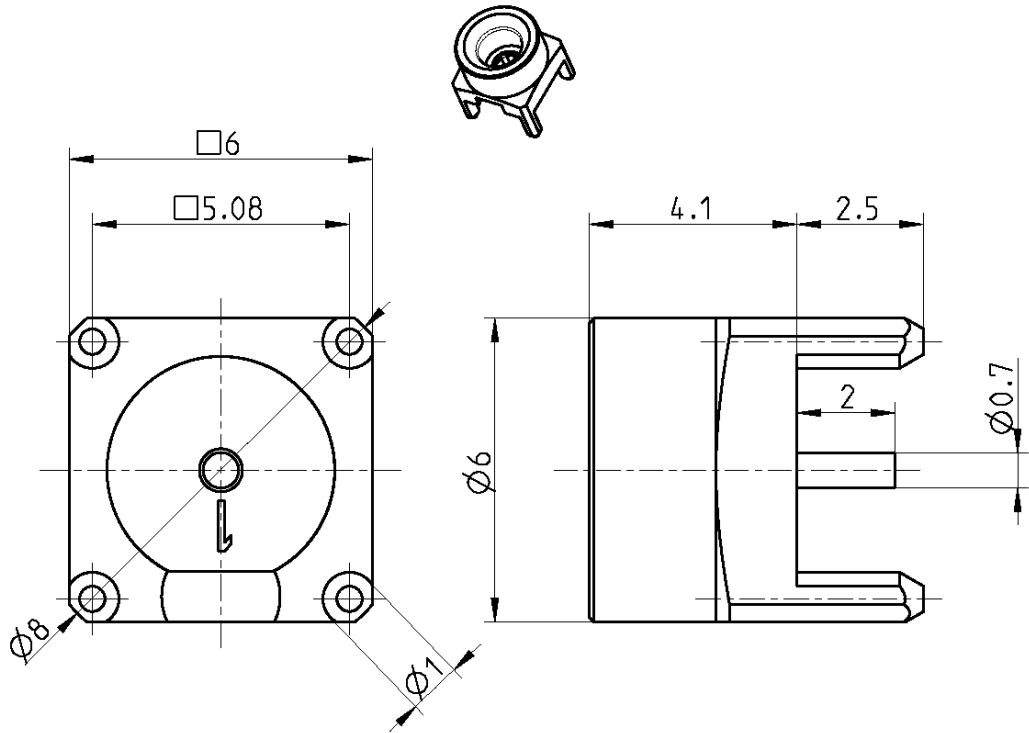

All dimensions are in mm; tolerances according to ISO 2768 m-H

**Interface**

Compatible to MIL-STD-348

**Documents**

PCB layout B 30  
Tape & reel packaging VG32.01M00

**Material and plating**

**Connector parts**

Center contact	Brass
Outer contact	Brass
Dielectric	PEEK

**Plating**

AuroDur®, gold plated  
AuroDur®, gold plated

Dieses Dokument ist urheberrechtlich geschützt • This document is protected by copyright • Rosenberger Hochfrequenztechnik GmbH & Co. KG

RF\_35/09.14/6.2

**Electrical data**

Impedance	50 Ω
Frequency	DC to 26.5 GHz
Return loss	≥ 26 dB, DC to 2 GHz ≥ 20 dB, 2 to 6 GHz
Insertion loss	≤ 0.05 x √f(GHz) dB; DC to 6 GHz
Insulation resistance	≥ 5 GΩ
Center contact resistance	≤ 6.0 mΩ
Outer contact resistance	≤ 2.0 mΩ
Test voltage	500 V rms
Working voltage	335 V rms
Contact Current	1.2A DC max.

- VSWR in application depends decisive on PCB layout -

**Mechanical data**

Mating cycles	≥ 500
Center contact captivation	≥ 7 N
Engagement force	9 N max.
Disengagement force	2.2 N min.

**Environmental data**

Temperature range	-65°C to +155°C
Thermal shock	MIL-STD-202, Method 107, Condition B
Vibration	MIL-STD-202, Method 204, Condition B
Shock	MIL-STD-202, Method 213, Condition A
Moisture resistance	MIL-STD-202, Method 106
Max. soldering temperature	IEC 61760-1, +260°C for 10 sec.
RoHS	compliant

**Tooling**

N/A

**Suitable cables**

N/A

**Weight**

Weight	0.77 g/pce
--------	------------

While the information has been carefully compiled to the best of our knowledge, nothing is intended as representation or warranty on our part and no statement herein shall be construed as recommendation to infringe existing patents. In the effort to improve our products, we reserve the right to make changes judged to be necessary.

For the installation of the electrotechnical equipment, particular electrotechnical expertise is required.



Draft	Date	Approved	Date	Rev.	Engineering change number	Name	Date
Andreas Fellner	07.05.07	Chr. Janßen	28.10.20	f00	20-1927	S. Huber-Siegl	28.10.20
Rosenberger Hochfrequenztechnik GmbH & Co. KG P.O.Box 1260 D-84526 Tittmoning Germany <a href="http://www.rosenberger.de">www.rosenberger.de</a>						Tel. : +49 8684 18-0 Email : <a href="mailto:info@rosenberger.de">info@rosenberger.de</a>	
							Page 2 / 2