

# Datasheet

## WB40NBT

*Version 3.12*

---

## REVISION HISTORY

| Version | Date         | Notes  | Approver      |
|---------|--------------|--|---------------|
| 1.0     | 02/24/12     | Initial Release Version.   | Andrew Chen   |
| 1.1     | 03/05/12     | Changed RSTN to RESET.   | Andrew Chen   |
| 1.2     | 03/20/12     | Resolved outstanding TBDs.<br>Added AS/NZS (Australia, New Zealand) certifications.<br>Updated AS/NZS links. | Andrew Chen   |
| 1.3     | 6/29/12      | Updated BT Transmit Power.   | Andrew Chen   |
| 1.4     | 7/5/12       | Updated Receiver Sensitivity Values.   | Andrew Chen   |
| 2.0     | 10/2/12      | Laird formatting and removal of schematic links to website.  | Andrew Chen   |
| 2.1     | 11/01/12     | Changed Voltage Rise Time maximum from 5 ms to 100 ms.   | Andrew Chen   |
| 3.0     | 1/29/13      | Updated Receive Sensitivity data   | Andrew Chen   |
| 3.1     | 1/30/13      | Updated 5ghz channel and 5ghz frequency data<br>Updated operating temperature data.                          | Andrew Chen   |
| 3.2     | 3/4/13       | Updated Pin Table.<br>Changed Operating and Storage Humidity (Specs Table)                                   | Andrew Chen   |
| 3.3     | 4/26/13      | Changed Operating and Storage Humidity (Specs Table)   | Andrew Chen   |
| 3.4     | 5/2/13       | Updated Intro. Updated operating Linux kernel and version used for testing.<br>Lowered Storage Humidity.     | Andrew Chen   |
| 3.5     | 17 May 13    | Added BT Priority <i>Important</i> note to the <a href="#">Block Diagram</a> .                               | Andrew Chen   |
| 3.6     | 14 Oct 13    | Removed references to summitdata.com   | Andrew Chen   |
| 3.7     | 11 Mar 14    | Added Bluetooth SIG section.   | Jonathan Kaye |
| 3.8     | 22 Oct 15    | Added Approved By section to Revision History; fixed internal links  | Sue White     |
| 3.9     | 15 Aug 16    | Changed <i>Hardware Integration Guide</i> to <i>Datasheet</i>  | Sue White     |
| 3.10    | 21 Feb 17    | Updated FCC data to 24 non-overlapping channels  | Jay White     |
| 3.11    | 14 June 17   | Updated the EU DoC for RED standards   | Tom Smith     |
| 3.12    | 20 June 2017 | Changed <b>EN 301 893 v2.1.0 (2017-03)</b> to <b>EN 301 893 v2.1.1 (2017-05)</b>                             | Tom Smith     |

## CONTENTS

|       |   |    |
|-------|---|----|
| 1     | Scope .....   | 4  |
| 2     | Product Description .....                                 | 4  |
| 3     | Block Diagram .....                                       | 5  |
| 4     | Specifications .....                                      | 6  |
| 5     | Electrical Characteristics.....                           | 10 |
| 5.1.1 | Absolute Maximum Ratings.....                             | 10 |
| 5.1.2 | Power Supply .....  | 10 |
| 5.1.3 | Reset Characteristics .....                               | 11 |
| 5.1.4 | I/O Pin Characteristics (including UART interfaces) ..... | 11 |
| 5.1.5 | USB Transceiver Characteristics .....                     | 12 |
| 6     | Pin Definitions .....                                     | 13 |
| 7     | Mechanical Specifications .....                           | 18 |
| 7.1   | Mounting .....  | 18 |
| 8     | Integration Guidelines .....                              | 19 |
| 9     | Regulatory .....  | 19 |
| 9.1   | Certified Antennas.....                                   | 19 |
| 9.2   | Documentation Requirements .....                          | 20 |
| 9.2.1 | FCC.....  | 20 |
| 9.2.2 | Industry Canada.....                                      | 22 |
| 9.2.3 | European Union.....                                       | 23 |

## 1 SCOPE

This document describes key hardware aspects of the Laird SDC-WB40NBT wireless bridge module. This document is intended to assist device manufacturers and related parties with the integration of this module into their host devices. Data in this document are drawn from a number of sources including data sheets for the Broadcom BCM4329 and Atmel AT91SAM9G20 CPU.

Please contact Laird or visit the Laird website to obtain the most recent version of this document:  
<http://www.lairdtech.com/Products/WB40NBT>

## 2 PRODUCT DESCRIPTION

The SDC-WB40NBT Wireless Bridge Module is a wireless communications subsystem that may be integrated into a variety of host devices via a number of available electronic and logical interfaces. The SDC-WB40NBT provides complete enterprise-class Wi-Fi connectivity with an integrated TCP/IP stack, full support for IEEE 802.11a/b/g/n air standards and a fully integrated security supplicant providing 802.11i/WPA2 Enterprise authentication and data encryption.

The SDC-WB40NBT has a wide variety of interfaces including Fast Ethernet, serial UART, USB, SPI and I2C. The wireless bridge may be configured, monitored and managed via a Command Line Interface over an available dedicated console port, via a web interface over a wireless or Ethernet interface, or via a remote SDK interface over wireless or Ethernet.

The SDC-WB40NBT incorporates the Laird SDC-SSD40NBT radio module and provides all the Wi-Fi capabilities of that device. The product features an ARM9 processor running at 396 MHz, 32 MB of SDRAM memory, and 64 MB of NAND flash storage. Several GPIO lines are available for data acquisition and similar applications. The platform runs an embedded Linux operating system based on the 3.2 kernel. A Software Developer's Kit with Application Programming Interfaces and software tools are available for the development of custom software applications on the device.

The SDC-WB40NBT measures 47 mm long by 37 mm wide by 3 mm tall. The wireless bridge physically interfaces to the host device via a 120 pin board to board connector that has a variety of mating options. The SDC-WB40NBT may be secured to the host device via available grounded mounting holes. The SDC-WB40NBT operates at temperatures between -30° to +80°C degrees Celsius.

SDC-WB40NBT is a fully integrated module: It has its own RF shielding and does not require shielding provided by the host device into which it is installed in order to maintain compliance with applicable regulatory standards. As such, the device may be tested in a standalone configuration via an extender card.

The SDC-WB40NBT provides two unique U.FL type antenna connectors to support dual band transmit and receive diversity. Supported host device antenna types include dipole and monopole antennas.

Regulatory operational requirements are included with this document and may be incorporated into the operating manual of any device into which the SDC-WB40NBT is installed. The SDC-WB40NBT is designed for installation into mobile devices which typically operate at distances greater than 20 cm from the human body and portable devices which typically operate at distances less than 20 cm from the human body. See "[Documentation Requirements](#)" for more information.



### 3 BLOCK DIAGRAM

The following is the SDC-WB40NBT block diagram:

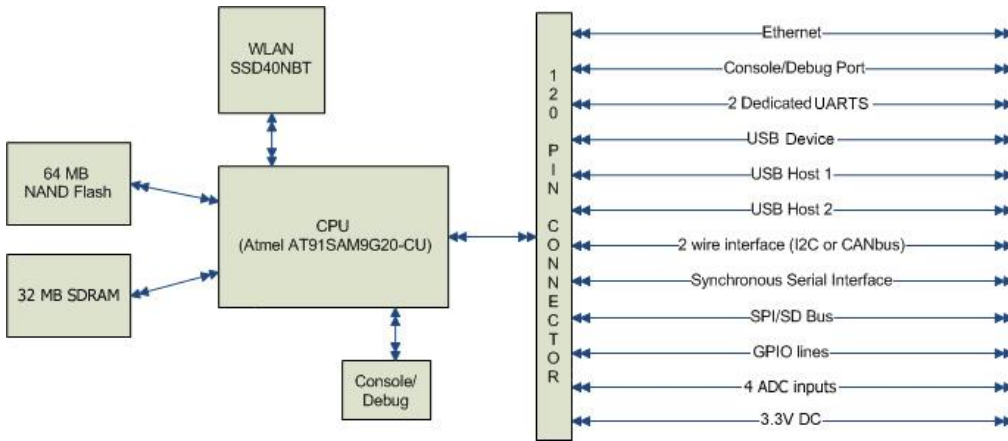

**Note:** Transmitter frequencies for Wi-Fi are 2412-2462 MHz and 5180-5805 MHz. Transmitter frequencies for BT are 2402-2480 MHz.

The SDC-SSD40NBT block diagram displays the RF circuitry of the SDC-WB40NBT.

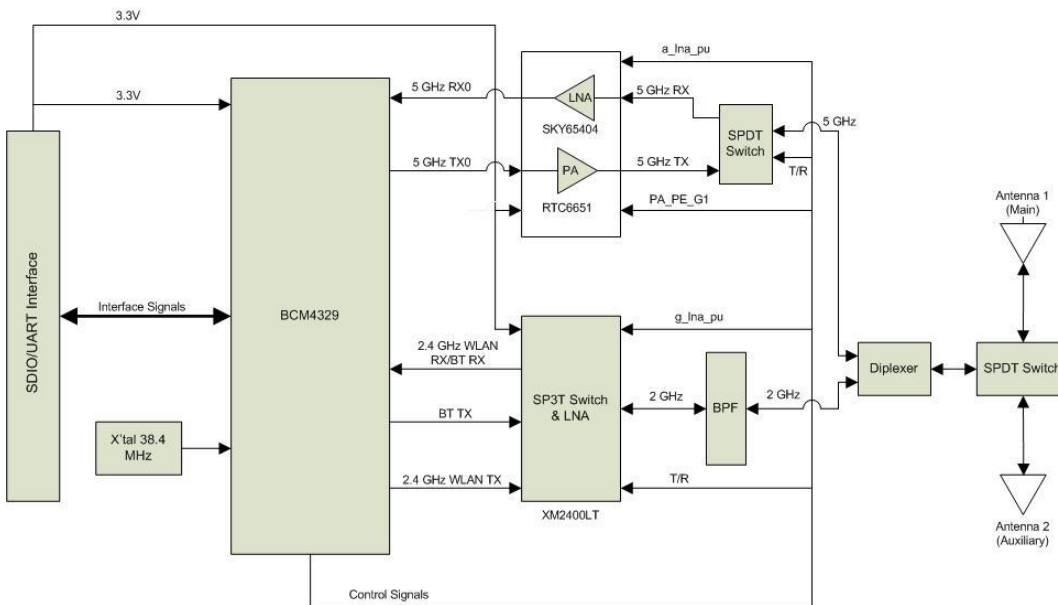

**Note:** BT functions on the AUX port and *not* on the Main port. For Wi-Fi and BT single-antenna implementations, the AUX port *must* be used.

**IMPORTANT:** When BT is transmitting high priority traffic (such as during a scan and/or when sending audio traffic) Wi-Fi receive is sent to the main antenna port (even when set to *AUX only*). When high priority transmission ends, Wi-Fi receive functionality returns to the AUX port (when set to *AUX only*). For optimal Wi-Fi performance, we recommend that you populate both the Main and the AUX ports with an antenna.

## 4 SPECIFICATIONS

| Feature  | Description  |                  |      |              |                |          |                  |         |                 |         |                |                |          |                  |         |                 |         |                |                |          |                  |         |                 |         |                |                          |          |                  |         |                 |         |                |                        |          |                  |         |                 |         |                |
|--|--|------------------|------|--------------|----------------|----------|------------------|---------|-----------------|---------|----------------|----------------|----------|------------------|---------|-----------------|---------|----------------|----------------|----------|------------------|---------|-----------------|---------|----------------|--------------------------|----------|------------------|---------|-----------------|---------|----------------|------------------------|----------|------------------|---------|-----------------|---------|----------------|
| <b>Physical Interface</b>  | Kyocera Elco Series 5046 120 Pin Connector P/N 24 5046 120 000 829+ (see Mounting Instructions for mating connector options)   |                  |      |              |                |          |                  |         |                 |         |                |                |          |                  |         |                 |         |                |                |          |                  |         |                 |         |                |                          |          |                  |         |                 |         |                |                        |          |                  |         |                 |         |                |
| <b>Ethernet Interface</b>  | 10/100 Mbps RMII (Reduced Media Independent Interface)   |                  |      |              |                |          |                  |         |                 |         |                |                |          |                  |         |                 |         |                |                |          |                  |         |                 |         |                |                          |          |                  |         |                 |         |                |                        |          |                  |         |                 |         |                |
| <b>Asynchronous Serial Port Interfaces (3.3 V TTL interface)</b> | Nine-wire UART DCE with full modem signaling, ring indication, and carrier detect<br>Four-wire UART with hardware handshaking<br>Two-wire UART ( console)  |                  |      |              |                |          |                  |         |                 |         |                |                |          |                  |         |                 |         |                |                |          |                  |         |                 |         |                |                          |          |                  |         |                 |         |                |                        |          |                  |         |                 |         |                |
| <b>Synchronous Serial Port Interface</b>                         | Six-wire   |                  |      |              |                |          |                  |         |                 |         |                |                |          |                  |         |                 |         |                |                |          |                  |         |                 |         |                |                          |          |                  |         |                 |         |                |                        |          |                  |         |                 |         |                |
| <b>Secure Digital I/O Interface</b>                              | Six Wire<br><b>Note:</b> Cannot be used simultaneously with SPI interface  |                  |      |              |                |          |                  |         |                 |         |                |                |          |                  |         |                 |         |                |                |          |                  |         |                 |         |                |                          |          |                  |         |                 |         |                |                        |          |                  |         |                 |         |                |
| <b>SPI Interface</b>   | Five Wire, Master and Slave modes supported<br><b>Note:</b> Cannot be used simultaneously with SDIO interface  |                  |      |              |                |          |                  |         |                 |         |                |                |          |                  |         |                 |         |                |                |          |                  |         |                 |         |                |                          |          |                  |         |                 |         |                |                        |          |                  |         |                 |         |                |
| <b>USB Interfaces</b>  | Two 12 Mbps USB Host Ports<br>One 12 Mbps USB Device Port  |                  |      |              |                |          |                  |         |                 |         |                |                |          |                  |         |                 |         |                |                |          |                  |         |                 |         |                |                          |          |                  |         |                 |         |                |                        |          |                  |         |                 |         |                |
| <b>Two Wire Interface</b>  | Two-wire I <sup>2</sup> C (Inter-IC) or CANbus (Controller-area Network)   |                  |      |              |                |          |                  |         |                 |         |                |                |          |                  |         |                 |         |                |                |          |                  |         |                 |         |                |                          |          |                  |         |                 |         |                |                        |          |                  |         |                 |         |                |
| <b>Antenna Interface</b>   | 2 Hirose U.FL connectors for dual-band antenna diversity, 50 ohm   |                  |      |              |                |          |                  |         |                 |         |                |                |          |                  |         |                 |         |                |                |          |                  |         |                 |         |                |                          |          |                  |         |                 |         |                |                        |          |                  |         |                 |         |                |
| <b>Wi-Fi Interface</b>   | Laird SDC-SSD40NBT   |                  |      |              |                |          |                  |         |                 |         |                |                |          |                  |         |                 |         |                |                |          |                  |         |                 |         |                |                          |          |                  |         |                 |         |                |                        |          |                  |         |                 |         |                |
| <b>Processor Chip Set</b>  | Atmel 400 MHz ARM 9, P/N AT91SAM9G20-CU  |                  |      |              |                |          |                  |         |                 |         |                |                |          |                  |         |                 |         |                |                |          |                  |         |                 |         |                |                          |          |                  |         |                 |         |                |                        |          |                  |         |                 |         |                |
| <b>Operating System</b>  | Embedded Linux, 3.2 kernel   |                  |      |              |                |          |                  |         |                 |         |                |                |          |                  |         |                 |         |                |                |          |                  |         |                 |         |                |                          |          |                  |         |                 |         |                |                        |          |                  |         |                 |         |                |
| <b>Memory</b>  | 32 MB SDRAM  |                  |      |              |                |          |                  |         |                 |         |                |                |          |                  |         |                 |         |                |                |          |                  |         |                 |         |                |                          |          |                  |         |                 |         |                |                        |          |                  |         |                 |         |                |
| <b>Storage</b>   | 64 MB NAND flash   |                  |      |              |                |          |                  |         |                 |         |                |                |          |                  |         |                 |         |                |                |          |                  |         |                 |         |                |                          |          |                  |         |                 |         |                |                        |          |                  |         |                 |         |                |
| <b>Input Voltage Requirements</b>                                | 3.3 VDC ±5% (core)   |                  |      |              |                |          |                  |         |                 |         |                |                |          |                  |         |                 |         |                |                |          |                  |         |                 |         |                |                          |          |                  |         |                 |         |                |                        |          |                  |         |                 |         |                |
| <b>Wi-Fi Current Consumption</b>                                 | <table border="1"> <thead> <tr> <th></th> <th>Mode</th> <th>Avg. Current</th> </tr> </thead> <tbody> <tr> <td rowspan="3"><b>802.11a</b></td> <td>Transmit</td> <td>369 mA (1218 mW)</td> </tr> <tr> <td>Receive</td> <td>167 mA (551 mW)</td> </tr> <tr> <td>Standby</td> <td>79 mA (261 mW)</td> </tr> <tr> <td rowspan="3"><b>802.11b</b></td> <td>Transmit</td> <td>392 mA (1294 mW)</td> </tr> <tr> <td>Receive</td> <td>167 mA (551 mW)</td> </tr> <tr> <td>Standby</td> <td>79 mA (261 mW)</td> </tr> <tr> <td rowspan="3"><b>802.11g</b></td> <td>Transmit</td> <td>355 mA (1294 mW)</td> </tr> <tr> <td>Receive</td> <td>167 mA (551 mW)</td> </tr> <tr> <td>Standby</td> <td>79 mA (261 mW)</td> </tr> <tr> <td rowspan="3"><b>802.11n (2.4 GHz)</b></td> <td>Transmit</td> <td>324 mA (1069 mW)</td> </tr> <tr> <td>Receive</td> <td>167 mA (551 mW)</td> </tr> <tr> <td>Standby</td> <td>79 mA (261 mW)</td> </tr> <tr> <td rowspan="3"><b>802.11n (5 GHz)</b></td> <td>Transmit</td> <td>359 mA (1185 mW)</td> </tr> <tr> <td>Receive</td> <td>167 mA (551 mW)</td> </tr> <tr> <td>Standby</td> <td>79 mA (261 mW)</td> </tr> </tbody> </table> |                  | Mode | Avg. Current | <b>802.11a</b> | Transmit | 369 mA (1218 mW) | Receive | 167 mA (551 mW) | Standby | 79 mA (261 mW) | <b>802.11b</b> | Transmit | 392 mA (1294 mW) | Receive | 167 mA (551 mW) | Standby | 79 mA (261 mW) | <b>802.11g</b> | Transmit | 355 mA (1294 mW) | Receive | 167 mA (551 mW) | Standby | 79 mA (261 mW) | <b>802.11n (2.4 GHz)</b> | Transmit | 324 mA (1069 mW) | Receive | 167 mA (551 mW) | Standby | 79 mA (261 mW) | <b>802.11n (5 GHz)</b> | Transmit | 359 mA (1185 mW) | Receive | 167 mA (551 mW) | Standby | 79 mA (261 mW) |
|  | Mode   | Avg. Current     |      |              |                |          |                  |         |                 |         |                |                |          |                  |         |                 |         |                |                |          |                  |         |                 |         |                |                          |          |                  |         |                 |         |                |                        |          |                  |         |                 |         |                |
| <b>802.11a</b>   | Transmit   | 369 mA (1218 mW) |      |              |                |          |                  |         |                 |         |                |                |          |                  |         |                 |         |                |                |          |                  |         |                 |         |                |                          |          |                  |         |                 |         |                |                        |          |                  |         |                 |         |                |
|  | Receive  | 167 mA (551 mW)  |      |              |                |          |                  |         |                 |         |                |                |          |                  |         |                 |         |                |                |          |                  |         |                 |         |                |                          |          |                  |         |                 |         |                |                        |          |                  |         |                 |         |                |
|  | Standby  | 79 mA (261 mW)   |      |              |                |          |                  |         |                 |         |                |                |          |                  |         |                 |         |                |                |          |                  |         |                 |         |                |                          |          |                  |         |                 |         |                |                        |          |                  |         |                 |         |                |
| <b>802.11b</b>   | Transmit   | 392 mA (1294 mW) |      |              |                |          |                  |         |                 |         |                |                |          |                  |         |                 |         |                |                |          |                  |         |                 |         |                |                          |          |                  |         |                 |         |                |                        |          |                  |         |                 |         |                |
|  | Receive  | 167 mA (551 mW)  |      |              |                |          |                  |         |                 |         |                |                |          |                  |         |                 |         |                |                |          |                  |         |                 |         |                |                          |          |                  |         |                 |         |                |                        |          |                  |         |                 |         |                |
|  | Standby  | 79 mA (261 mW)   |      |              |                |          |                  |         |                 |         |                |                |          |                  |         |                 |         |                |                |          |                  |         |                 |         |                |                          |          |                  |         |                 |         |                |                        |          |                  |         |                 |         |                |
| <b>802.11g</b>   | Transmit   | 355 mA (1294 mW) |      |              |                |          |                  |         |                 |         |                |                |          |                  |         |                 |         |                |                |          |                  |         |                 |         |                |                          |          |                  |         |                 |         |                |                        |          |                  |         |                 |         |                |
|  | Receive  | 167 mA (551 mW)  |      |              |                |          |                  |         |                 |         |                |                |          |                  |         |                 |         |                |                |          |                  |         |                 |         |                |                          |          |                  |         |                 |         |                |                        |          |                  |         |                 |         |                |
|  | Standby  | 79 mA (261 mW)   |      |              |                |          |                  |         |                 |         |                |                |          |                  |         |                 |         |                |                |          |                  |         |                 |         |                |                          |          |                  |         |                 |         |                |                        |          |                  |         |                 |         |                |
| <b>802.11n (2.4 GHz)</b>   | Transmit   | 324 mA (1069 mW) |      |              |                |          |                  |         |                 |         |                |                |          |                  |         |                 |         |                |                |          |                  |         |                 |         |                |                          |          |                  |         |                 |         |                |                        |          |                  |         |                 |         |                |
|  | Receive  | 167 mA (551 mW)  |      |              |                |          |                  |         |                 |         |                |                |          |                  |         |                 |         |                |                |          |                  |         |                 |         |                |                          |          |                  |         |                 |         |                |                        |          |                  |         |                 |         |                |
|  | Standby  | 79 mA (261 mW)   |      |              |                |          |                  |         |                 |         |                |                |          |                  |         |                 |         |                |                |          |                  |         |                 |         |                |                          |          |                  |         |                 |         |                |                        |          |                  |         |                 |         |                |
| <b>802.11n (5 GHz)</b>   | Transmit   | 359 mA (1185 mW) |      |              |                |          |                  |         |                 |         |                |                |          |                  |         |                 |         |                |                |          |                  |         |                 |         |                |                          |          |                  |         |                 |         |                |                        |          |                  |         |                 |         |                |
|  | Receive  | 167 mA (551 mW)  |      |              |                |          |                  |         |                 |         |                |                |          |                  |         |                 |         |                |                |          |                  |         |                 |         |                |                          |          |                  |         |                 |         |                |                        |          |                  |         |                 |         |                |
|  | Standby  | 79 mA (261 mW)   |      |              |                |          |                  |         |                 |         |                |                |          |                  |         |                 |         |                |                |          |                  |         |                 |         |                |                          |          |                  |         |                 |         |                |                        |          |                  |         |                 |         |                |
| <b>Operating Temperature</b>                                     | -30° to 80°C (-22° to 176°F)   |                  |      |              |                |          |                  |         |                 |         |                |                |          |                  |         |                 |         |                |                |          |                  |         |                 |         |                |                          |          |                  |         |                 |         |                |                        |          |                  |         |                 |         |                |
| <b>Operating Humidity</b>  | 10% to 90% (non-condensing)  |                  |      |              |                |          |                  |         |                 |         |                |                |          |                  |         |                 |         |                |                |          |                  |         |                 |         |                |                          |          |                  |         |                 |         |                |                        |          |                  |         |                 |         |                |
| <b>Storage Temperature</b>                                       | -30° to 85°C (-22° to 185°F)   |                  |      |              |                |          |                  |         |                 |         |                |                |          |                  |         |                 |         |                |                |          |                  |         |                 |         |                |                          |          |                  |         |                 |         |                |                        |          |                  |         |                 |         |                |
| <b>Storage Humidity</b>  | 5% to 90% (non-condensing)   |                  |      |              |                |          |                  |         |                 |         |                |                |          |                  |         |                 |         |                |                |          |                  |         |                 |         |                |                          |          |                  |         |                 |         |                |                        |          |                  |         |                 |         |                |

**Note:** These current consumption measurements were taken using Linux kernel version 3.2.0.

**Note:** Standby refers to the radio operating in PM1 powersave mode.

**Note:** During calibration and initialization the SDC-WB40NBT may reach a 700 mA peak, which only lasts several milliseconds.

|  |   |
|--|---|
| <b>Maximum Electrostatic Discharge</b> | Maximum Contact Discharge (CD): 4 kV<br>Maximum Air Discharge (AD): 8 kV  |
| <b>Length</b>                          | 47 mm (1.85")<br><i>Note: Length, width, and thickness measurements include the metal shielding.</i>  |
| <b>Width</b>                           | 37 mm (1.46")   |
| <b>Thickness</b>                       | 3.6 mm (0.14")  |
| <b>Weight</b>                          | 7.8 g (0.275oz)   |
| <b>Mounting</b>                        | Connector and Through Holes, See "Mounting" section for more information.   |
| <b>Wi-Fi Media</b>                     | Direct Sequence-Spread Spectrum (DSSS)<br>Complementary Code Keying (CCK)<br>Orthogonal Frequency Divisional Multiplexing (OFDM)  |
| <b>Wi-Fi Media Access Protocol</b>     | Carrier sense multiple access with collision avoidance (CSMA/CA)  |
| <b>Network Architecture</b>            | Infrastructure and ad hoc   |
| <b>Wi-Fi Standards</b>                 | IEEE 802.11a, 802.11b, 802.11d, 802.11e, 802.11g, 802.11h, 802.11i, 802.11n   |
| <b>Wi-Fi Data Rates Supported</b>      | 802.11a (OFDM) 6, 9, 12, 18, 24, 36, 48, 54 Mbps<br>802.11b (DSSS, CCK) 1, 2, 5.5, 11 Mbps<br>802.11g (OFDM) 6, 9, 12, 18, 24, 36, 48, 54 Mbps<br>802.11n (OFDM, MCS 0-7) 6.5, 7.2, 13.0, 14.4, 19.5, 21.7, 26.0, 28.9, 39.0, 43.3, 52.0, 57.8, 58.5, 65.0, 72.2 Mbps |
| <b>Modulation</b>                      | BPSK @ 1, 6, 6.5, 7.2 and 9 Mbps<br>QPSK @ 2, 12, 13, 14.4, 18, 19.5 and 21.7 Mbps<br>CCK @ 5.5 and 11 Mbps<br>16-QAM @ 24, 26, 28.9, 36, 39 and 43.3 Mbps<br>64-QAM @ 48, 52, 54, 57.8, 58.5, 65, and 72.2 Mbps  |
| <b>802.11n Spatial Streams</b>         | 1 (Single Input, Single Output)   |
| <b>Regulatory Domain Support</b>       | FCC (Americas, Parts of Asia, and Middle East)<br>ETSI (Europe, Middle East, Africa, and Parts of Asia)<br>MIC (Japan) (formerly TELEC)<br>KC (Korea) (formerly KCC)  |
| <b>2.4 GHz Frequency Bands</b>         | <b>ETSI</b><br>2.4 GHz to 2.483 GHz<br><b>FCC</b><br>2.4 GHz to 2.483 GHz<br><b>MIC (Japan)</b><br>2.4 GHz to 2.495 GHz<br><b>KC</b><br>2.4 GHz to 2.483  |
| <b>2.4 GHz Operating Channels</b>      | ETSI: 13 (3 non-overlapping)<br>FCC: 11 (3 non-overlapping)<br>MIC (Japan): 14 (4 non-overlapping)  |

|   |   |  |
|---|---|--|
|   | KC: 13 (3 non-overlapping)  |  |
| <b>5 GHz Frequency Bands</b>  | <b>ETSI</b><br>5.15 GHz to 5.35 GHz<br>5.47 GHz to 5.725 GHz<br><b>FCC</b><br>5.15 GHz to 5.35 GHz<br>5.47 GHz to 5.725 GHz<br>5.725 GHz to 5.82 GHz<br><b>MIC (Japan)</b><br>5.15 GHz to 5.35 GHz<br><b>KC</b><br>5.15 GHz to 5.35 GHz<br>5.725 GHz to 5.82 GHz  |  |
| <b>5 GHz Operating Channels</b>   | ETSI: 19 non-overlapping<br>FCC: 24 non-overlapping<br>MIC (Japan): 8 non-overlapping<br>KC: 12 non-overlapping   |  |
| <b>Maximum Transmit Power</b>   | <b>802.11a</b><br>6 Mbps      16 dBm (40 mW)<br>54 Mbps     14 dBm (25 mW)<br><b>802.11b</b><br>1 Mbps      17 dBm (50 mW)<br>11 Mbps     16 dBm (40 mW)<br><b>802.11g</b><br>6 Mbps      15 dBm (32 mW)<br>54 Mbps     13 dBm (20 mW)<br><b>802.11n (2.4 GHz)</b><br>6.5 Mbps (MCS0)    15 dBm (32 mW)<br>65 Mbps (MCS7)    11 dBm (13 mW)<br><b>802.11n (5 GHz)</b><br>6.5 Mbps (MCS0)    16 dBm (40 mW)<br>65 Mbps (MCS7)    13 dBm (20 mW)<br><b>Bluetooth</b><br>0 dBm (1mW) (Class 2) |  |
| <b>Typical Receiver Sensitivity</b>   | <b>802.11a:</b><br>6 Mbps            -90 dBm<br>24 Mbps          -84 dBm<br>54 Mbps          -75 dBm (PER <= 10%)<br><b>802.11b:</b><br>1 Mbps            -96 dBm<br>11 Mbps          -89 dBm (PER <= 10%)<br><b>802.11g:</b>   |  |
| <i>Note: Maximum transmit power varies according to individual country regulations. All values nominal, +/-2 dBm.</i> |   |  |
| <i>Note: Laird 40 series radios support a single spatial stream and 20 MHz channels only.</i>                         |   |  |
| <i>Note: All values nominal, +/-3 dBm.</i>  |   |  |



|                          |                      |
|--------------------------|----------------------|
| 6 Mbps                   | -90 dBm              |
| 24 Mbps                  | -84 dBm              |
| 54 Mbps                  | -74 dBm (PER <= 10%) |
| <b>802.11n (2.4 GHz)</b> |                      |
| MCS0 Mbps                | -90 dBm              |
| MCS4 Mbps                | -79 dBm              |
| MCS7 Mbps                | -72 dBm              |
| <b>802.11n (5 GHz)</b>   |                      |
| MCS0 Mbps                | -89 dBm              |
| MCS4 Mbps                | -79 dBm              |
| MCS7 Mbps                | -71 dBm              |
| <b>Bluetooth:</b>        |                      |
| 1 Mbps                   | TBD                  |
| 2 Mbps                   | TBD                  |
| 3 Mbps                   | TBD                  |

**Security**

**Standards**

Wireless Equivalent Privacy (WEP)  
 Wi-Fi Protected Access (WPA)  
 IEEE 802.11i (WPA2)

**Encryption**

Wireless Equivalent Privacy (WEP, RC4 Algorithm)  
 Temporal Key Integrity Protocol (TKIP, RC4 Algorithm)  
 Advanced Encryption Standard (AES, Rijndael Algorithm)

**Encryption Key Provisioning**

Static (40-bit and 128-bit lengths)  
 Pre-Shared (PSK)  
 Dynamic

**802.1X Extensible Authentication Protocol Types**

EAP-FAST  
 EAP-TLS  
 EAP-TTLS  
 PEAP-GTC  
 PEAP-MSCHAPv2  
 PEAP-TLS  
 LEAP

**Compliance**

**ETSI Regulatory Domain**

EN 300 328  
 EN 300 328 v1.7.1 (BT 2.1)  
 EN 301 489-1  
 EN 301 489-17  
 EN 301 893  
 EN60950-1  
 EN55022:2010 Class B

EU 2002/95/EC (RoHS)  
**FCC Regulatory Domain**  
 FCC 15.247 DTS – 802.11b/g (Wi-Fi) – 2.4 GHz & 5.8 GHz  
 FCC 15.407 UNII – 802.11a (Wi-Fi) – 2.4 GHz & 5.4 GHz  
 FCC 15.247 DSS – BT 2.1  
**Industry Canada**  
 RSS-210 – 802.11a/b/g/n (Wi-Fi) – 2.4 GHz, 5.8 GHz, 5.2 GHz, and 5.4 GHz  
 RSS-210 – BT 2.1  
**MIC (Japan) Regulatory Domain (formerly TELEC) (PENDING)**  
 Article 2 Item 19, Category WW (2.4GHz Channels 1-13)  
 Article 2 Item 19-2, Category GZ (2.4GHz Channel 14)  
 Article 2 Item 19-3 Category XW (5150-5250 W52 & 5250-5350 W53)VCCI Class B  
 Article 2-1 Item 19-2 (BT 2.1)  
 National Communications Commission (NCC):  
 LP0002 (100-06-28) - Wi-Fi  
 LP0002 (100-06-28) - Bluetooth  
**AS/NZS**  
 AS/NZS 4268:2008 +A1:2010 (RLAN device)  
 AS/NZS 4268:2008 +A1:2010 (BT device)

**Certifications**

**Wi-Fi Alliance**  
 802.11a, 802.11b, 802.11g , 802.11n  
 WPA Enterprise  
 WPA2 Enterprise  
**Cisco Compatible Extensions (Version 4)**



**Warranty**

Limited Lifetime

*All specifications are subject to change without notice*

## 5 ELECTRICAL CHARACTERISTICS

### 5.1.1 Absolute Maximum Ratings

| Parameter                | Comments   | Conditions             | Min. | Typ. | Max. | Unit |
|--------------------------|------------|------------------------|------|------|------|------|
| <b>Input Voltage</b>     | VCC pin    | With respect to ground | -0.3 | -    | 3.6  | V    |
|                          | Any IO pin |                        | -0.3 | -    | 3.6  |      |
| <b>DC Output Current</b> | Any IO pin |                        | -    | -    | 8    | mA   |

### 5.1.2 Power Supply

| Parameter                | Comments        | Conditions         | Min. | Typ. | Max. | Unit |
|--------------------------|-----------------|--------------------|------|------|------|------|
| <b>Supply Voltage</b>    | VCC             |                    | 3.0  | 3.3  | 3.45 | V    |
| <b>Voltage Ripple</b>    |                 |                    | -    | -    | 100  | mV   |
| <b>Voltage Rise Time</b> | At power on     |                    | -    | -    | 100  | ms   |
| <b>Operating Current</b> | WLAN sub-system | Continuous receive | -    | 200  | 260  | mA   |
|                          |                 | IEEE PSM           | 10   | -    | -    |      |

|                |                         |   |     |     |    |
|----------------|-------------------------|---|-----|-----|----|
|                | Continuous transmit     | - | 360 | 450 |    |
| CPU sub-system | Varies with system load | - | 35  | 150 | mA |

### 5.1.3 Reset Characteristics

| Parameter                          | Comments  | Conditions                                  | Min. | Typ. | Max. | Unit |
|------------------------------------|---|---|------|------|------|------|
| Under voltage Threshold Level      | VCC to GND  | VCC falling                                 | 2.59 | -    | 2.67 | V    |
| Under voltage Threshold Hysteresis |   |   | -    | 55.2 | *    | mV   |
| Reset Delay                        | Power on or under voltage                           |   | 0.9  | 1.1  | 1.4  | s    |
| External Reset Pulse Width         | Reset driven low by external circuitry              |   | 92   | -    | -    | μs   |
| Output Current High Level RESET    | Internal reset controller drives external circuitry | $U_H = 2.0\text{ V}$                        | -    | -    | 650  | μA   |
| Input Current Low Level RESET      | Manual reset from external circuitry                | Internal reset controller drives high level | 2.2  | -    | -    | mA   |

### 5.1.4 I/O Pin Characteristics (including UART interfaces)

| Parameter                      | Comments              | Conditions             | Min.        | Typ. | Max. | Unit |
|--------------------------------|-----------------------|------------------------|-------------|------|------|------|
| Input Low Level Voltage        |                       |                        | -           | -    | 0.8  | V    |
| Input High Level Voltage       |                       |                        | 2.0         | -    | -    | V    |
| Output Low Level Voltage       |                       | $I_{OL} = 8\text{ mA}$ | -           | -    | 0.4  | V    |
|                                |                       | $I_{OL} = 0\text{ mA}$ | -           | -    | 0.2  |      |
| Output High Level Voltage      |                       | $I_{OL} = 8\text{ mA}$ | $VCC - 0.4$ | -    | -    | V    |
|                                |                       | $I_{OL} = 0\text{ mA}$ | $VCC - 0.2$ | -    | -    | V    |
| Output High Level Voltage LED0 |                       | $I_{OL} = 6\text{ mA}$ | $VCC - 0.4$ | -    | -    | V    |
| Input Leakage Current          |                       | Pull-up-disabled       | -           | -    | 1    | μA   |
| Input Pull-Up Current          | $V_{in} = 0\text{ V}$ | $VCC = 3.0\text{ V}$   | 8           | -    | -    | μA   |
|                                |                       | $VCC = 3.45\text{ V}$  | -           | -    | 30   |      |
| Internal Pull-Up Value         |                       |                        | -           | 200  | -    | kOhm |

### 5.1.5 USB Transceiver Characteristics

| Parameter                            | Comments   | Conditions                      | Min. | Typ. | Max.   | Unit |
|--------------------------------------|------------|---------------------------------|------|------|--------|------|
| Input Low Level Voltage              |            |                                 | -    | -    | 0.8    | V    |
| Input High Level Voltage             |            |                                 | 2.0  | -    | -      | V    |
| Differential Input Sensitivity       |            |                                 | 0.2  | -    | -      | V    |
| Differential Input Common Mode Range |            |                                 | 0.8  | -    | 2.5    | V    |
| Transceiver Capacitance              |            | To ground, each line            | -    | -    | 20     | pF   |
| High-Z State Data Line Leakage       |            | 0V < Vin < 3.3V                 | -5   |      | 5      | μA   |
| Recommended External Series Resistor |            | In each data line, 5% tolerance | -    | 27   | -      | Ohm  |
| Low Level Output                     |            | RL = 1.425 kOhm<br>Tied to 3.6V | -    | -    | 0.3    | V    |
| High Level Output                    |            | RL = 1.425 kOhm<br>Tied to GND  | 2.8  | -    | -      | V    |
| Output Signal Crossover Voltage      |            |                                 | 1.3  | -    | 2.0    | V    |
| Transition Rise Time                 | Slow Speed | CL = 400 pF                     | 75   | -    | 300    | ns   |
| Transition Fall Time                 | Slow Speed | CL = 400 pF                     | 75   | -    | 300    | ns   |
| Rise/Fall Time Matching              | Slow Speed | CL = 400 pF                     | 80   | -    | 120    | %    |
| Transition Rise Time                 | Full Speed | CL = 50 pF                      | 4    | -    | 20     | ns   |
| Transition Fall Time                 | Full Speed | CL = 50 pF                      | 4    | -    | 20     | ns   |
| Rise/Fall Time Matching              | Full Speed | CL = 50 pF                      | 90   | -    | 111.11 | %    |

## 6 PIN DEFINITIONS

**Note:** Unused pins should be left open. All GND pin shall be connected to system ground.

**Note:** The maximum output current is 8 mA except for the following pins (which have a maximum output current of 2 mA): 3, 4, 6, 8, 14, 16, 41, 47, 72, 87, and 89.

| Pin # | Name        | Section       | I/O | Reference | Description  | If unused                |
|-------|-------------|---------------|-----|-----------|--|--------------------------|
| 1     | GND         | SPI           | --  | --        | Signal Ground  | Must be connected to GND |
| 2     | GPIO_1/ADC0 | GPIO          | I/O | VCC3_3    | General Purpose I/O  | Leave open               |
| 3     | SPI1_NPCS_1 | SPI           | O   | VCC3_3    | SPI1 Peripheral Chip Select 1  | Leave open               |
| 4     | GPIO_2/ADC1 | GPIO          | I/O | VCC3_3    | General Purpose I/O  | Leave open               |
| 5     | SPI1_NPCS_0 | SPI           | O   | VCC3_3    | SPI1 Peripheral Chip Select 0  | Leave open               |
| 6     | PC22        | GPIO          | I   | VCC3_3    | Reserved for input to BT device. Indicates that Bluetooth is transmitting or receiving high priority packets (i.e., SCO and LMP). Not currently supported in the firmware. | Leave open               |
| 7     | GND         | SPI           | --  | --        | Signal Ground  | Must be connected to GND |
| 8     | PC23        | GPIO          | O   | VCC3_3    | Output to BT device. Indicates that the WLAN is transmitting or receiving high priority packets. Not currently supported in the firmware.                                  | Leave open               |
| 9     | SPI1_MOSI   | SPI           | O   | VCC3_3    | SPI1 Master Out / Slave In   | Leave open               |
| 10    | DRXD        | DBGU          | I   | VCC3_3    | Console / Debug Serial Input   | 47K pull-up              |
| 11    | SPI1_MISO   | SPI           | I   | VCC3_3    | SPI1 Master In / Slave Out   | 47K pull-up              |
| 12    | DTXD        | DBGU          | O   | VCC3_3    | Console / Debug Serial Output  | Leave open               |
| 13    | GND         | SPI           | --  | --        | Signal Ground  | Must be connected to GND |
| 14    | PC24        | GPIO          | I/O | VCC3_3    | General-purpose use  | Leave open               |
| 15    | SPI1_CLK    | SPI           | O   | VCC3_3    | SPI Serial Clock   | Leave open               |
| 16    | PC25        | GPIO          | I/O | VCC3_3    | General-purpose use  | Leave open               |
| 17    | GND         | Ethernet RMII | --  | --        | Signal Ground  | Must be connected to GND |
| 18    | LED0        | LED           | O   | VCC3_3    | General purpose LED0 out; Active low   | Leave open               |
| 19    | EREFLCK     | Ethernet RMII | I   | VCC3_3    | Ethernet Reference Clock (50 Mhz max)  | Leave open               |
| 20    | LED1        | LED           | O   | VCC3_3    | General purpose LED1 out; Active low   | Leave open               |
| 21    | GND         | Ethernet RMII | --  | --        | Signal Ground  | Must be connected to GND |
| 22    | LED2        | LED           | O   | VCC3_3    | General purpose LED2 out; Active low   | Leave open               |
| 23    | ETX0        | Ethernet RMII | O   | VCC3_3    | Ethernet data output 0   | Leave open               |

| Pin # | Name      | Section            | I/O | Reference | Description  | If unused                |
|-------|-----------|--------------------|-----|-----------|--|--------------------------|
| 24    | STAT0     | Status             | O   | VCC3_3    | Status High while system in reset, bootloader or OS boot, low when OS is up  | Leave open               |
| 25    | ETX1      | Ethernet RMII      | O   | VCC3_3    | Ethernet data output 1   | Leave open               |
| 26    | STAT1     | Status             | O   | VCC3_3    | Status High while system running, low while system in suspend state  | Leave open               |
| 27    | GND       | Ethernet RMII      | --  |           | Signal Ground  | Must be connected to GND |
| 28    | /PWDN     | Control            | I   | VCC3_3    | Powers down the module, active low   | Leave open               |
| 29    | ERX0      | Ethernet RMII      | I   | VCC3_3    | Ethernet Data Input 0  | Leave open               |
| 30    | /RESET    | Control            | I/O | VCC3_3    | This line will be pulled low momentarily during power-on by the CPU's internal power-on circuitry. The CPU then samples the state of this line after it de-asserts /RESET. Therefore, do not add more than 100pF external capacitance to this pin outside of the module. | Leave open               |
| 31    | ERX1      | Ethernet RMII      | I   | VCC3_3    | Ethernet Data Input 1  | Leave open               |
| 32    | GND       | Two Wire Interface | --  | --        | Signal Ground  | Must be connected to GND |
| 33    | GND       | Ethernet RMII      | --  | --        | Signal Ground  | Must be connected to GND |
| 34    | TWD       | Two Wire Interface | I/O | VCC3_3    | Two-wire Serial Data   | Leave open               |
| 35    | ETXEN     | Ethernet RMII      | O   | VCC3_3    | Ethernet Transmit Enable   | Leave open               |
| 36    | TWCK      | Two Wire Interface | I/O | VCC3_3    | Two-wire Serial Clock  | Leave open               |
| 37    | ECRSDV    | Ethernet RMII      | I   | VCC3_3    | Ethernet Carrier Sense and Data Valid  | Leave open               |
| 38    | GND       | UART1              | --  | --        | Signal Ground  | Must be connected to GND |
| 39    | ERXER     | Ethernet RMII      | I   | VCC3_3    | Ethernet Receive Error   | Leave open               |
| 40    | TXD1      | UART1              | O   | VCC3_3    | Serial UART1 Transmit Data   | Leave open               |
| 41    | ERST/ADC2 | Ethernet RMII      | O   | VCC3_3    | Ethernet Reset   | Leave open               |
| 42    | RXD1      | UART1              | I   | VCC3_3    | Serial UART1 Receive Data  | 47K pull-up              |
| 43    | EMDC      | Ethernet RMII      | O   | VCC3_3    | Ethernet Management Data Clock   | Leave open               |
| 44    | CTS1      | UART1              | I   | VCC3_3    | Serial UART1 Clear To Send; Active low   | 47K pull-up              |
| 45    | EMDIO     | Ethernet RMII      | I/O | VCC3_3    | Ethernet Management Data Input/Output  | Leave open               |
| 46    | RTS1      | UART1              | O   | VCC3_3    | Serial UART1 Request To Send; Active low   | Leave open               |

| Pin # | Name       | Section       | I/O | Reference | Description                              | If unused                |
|-------|------------|---------------|-----|-----------|--|--------------------------|
| 47    | EMIRO/ADC3 | Ethernet RMII | I   | VCC3_3    | Ethernet Interrupt Request               | Leave open               |
| 48    | GND        | UART0 (DCE)   | --  | --        | Signal Ground                            | Must be connected to GND |
| 49    | GND        | MMC/SD        | --  | --        | Signal Ground                            | Must be connected to GND |
| 50    | CTS0       | UART0 (DCE)   | I   | VCC3_3    | Serial UART0 Clear To Send; Active low   | 47K pull-up              |
| 51    | MCDA3      | MMC/SD        | I/O | VCC3_3    | SD/MMC Slot A Data 3                     | Leave open               |
| 52    | RTS0       | UART0 (DCE)   | O   | VCC3_3    | Serial UART0 Request To Send; Active low | Leave open               |
| 53    | MCDA2      | MMC/SD        | I/O | VCC3_3    | SD/MMC Slot A Data 2                     | Leave open               |
| 54    | DSR0       | UART0 (DCE)   | I   | VCC3_3    | Serial UART0 Data Set Ready              | 47K pull-up              |
| 55    | GND        | MMC/SD        | --  | --        | Signal Ground                            | Must be connected to GND |
| 56    | DTR0       | UART0 (DCE)   | O   | VCC3_3    | Serial UART0 Data Terminal Ready         | Leave open               |
| 57    | MCDA1      | MMC/SD        | I/O | VCC3_3    | SD/MMC Slot A Data 1                     | Leave open               |
| 58    | RI0        | UART0 (DCE)   | I   | VCC3_3    | Serial UART0 Ring Indicate               | 47K pull-up              |
| 59    | MCDA0      | MMC/SD        | I/O | VCC3_3    | SD/MMC Slot A Data 0                     | Leave open               |
| 60    | DCD0       | UART0 (DCE)   | I   | VCC3_3    | Serial UART0 Data Carrier Detect         | 47K pull-up              |
| 61    | GND        | MMC/SD        | --  | --        | Signal Ground                            | Must be connected to GND |
| 62    | GND        | UART0 (DCE)   | --  | --        | Signal Ground                            | Must be connected to GND |
| 63    | MCCK       | MMC/SD        | O   | VCC3_3    | SD/MMC Clock                             | Leave open               |
| 64    | SCK0       | UART0 (DCE)   | I/O | VCC3_3    | Serial UART0 Serial Clock                | Leave open               |
| 65    | GND        | MMC/SD        | --  | --        | Signal Ground                            | Must be connected to GND |
| 66    | TXD0       | UART0 (DCE)   | O   | VCC3_3    | Serial UART0 Serial Transmit             | Leave open               |
| 67    | MCCDA      | MMC/SD        | I/O | VCC3_3    | SD/MMC Command                           | Leave open               |
| 68    | RXD0       | UART0 (DCE)   | I   | VCC3_3    | Serial UART0 Serial Receive              | 47K pull-up              |
| 69    | GND        | MMC/SD        | --  | --        | Signal Ground                            | Must be connected to GND |
| 70    | GND        | Reserved      | --  | --        | Signal Ground                            | Must be connected to GND |
| 71    | TK         | SSI           | I/O | VCC3_3    | Transmit Clock                           | Leave open               |
| 72    | IRQ0       | Control       | I   | VCC3_3    | No Connect; Reserved for future use      | Leave open               |
| 73    | TD         | SSI           | O   | VCC3_3    | Transmit Data                            | Leave open               |
| 74    | --         | Reserved      | --  | --        | No Connect; Reserved for future use      | Leave open               |
| 75    | TF         | SSI           | I/O | VCC3_3    | Transmit Frame Sync                      | Leave open               |
| 76    | GND        | Reserved      | --  | --        | Signal Ground                            | Must be connected to GND |

| Pin # | Name      | Section      | I/O | Reference | Description   | If unused                |
|-------|-----------|--------------|-----|-----------|---|--------------------------|
| 77    | GND       | SSI          | --  | --        | Signal Ground   | Must be connected to GND |
| 78    | --        | Reserved     | --  | --        | No Connect; Reserved for future use                             | Leave open               |
| 79    | RK        | SSI          | I/O | VCC3_3    | Receive Clock   | Leave open               |
| 80    | --        | Reserved     | --  | --        | No Connect; Reserved for future use                             | Leave open               |
| 81    | RD        | SSI          | I   | VCC3_3    | Receive Data  | Leave open               |
| 82    | GND       | Reserved     | --  | --        | Signal Ground   | Must be connected to GND |
| 83    | RF        | SSI          | I/O | VCC3_3    | Receive Frame Sync  | Leave open               |
| 84    | --        | Reserved     | --  | --        | No Connect; Reserved for future use                             | Leave open               |
| 85    | GND       | USB Device   | --  | --        | Signal Ground   | Must be connected to GND |
| 86    | --        | Reserved     | --  | --        | No Connect; Reserved for future use                             | Leave open               |
| 87    | DPUCNTRL  | USB Device   | O   | VCC3_3    | USB device pull-up resistor enable, active high                 | Leave open               |
| 88    | --        | Reserved     | --  | --        | No Connect; Reserved for future use                             | Leave open               |
| 89    | DBUSSENSE | USB Device   | I   | VCC3_3    | USB device bus sense signal from peripheral to host, active low | 47K pull-up              |
| 90    | --        | Reserved     | --  | --        | No Connect; Reserved for future use                             | Leave open               |
| 91    | GND       | USB Device   | --  | --        | Signal Ground   | Must be connected to GND |
| 92    | --        | Reserved     | --  | --        | No Connect; Reserved for future use                             | Leave open               |
| 93    | DDM       | USB Device   | I/O | VCC3_3    | USB Device Data Negative  | Leave open               |
| 94    | --        | Reserved     | --  | --        | No Connect; Reserved for future use                             | Leave open               |
| 95    | DDP       | USB Device   | I/O | VCC3_3    | USB Device Data Positive  | Leave open               |
| 96    | --        | Reserved     | --  | --        | No Connect; Reserved for future use                             | Leave open               |
| 97    | GND       | USB Host A   | --  | --        | Signal Ground   | Must be connected to GND |
| 98    | --        | Reserved     | --  | --        | No Connect; Reserved for future use                             | Leave open               |
| 99    | HDMA      | USB Host A   | I/O | VCC3_3    | USB Host A Data Negative  | Leave open               |
| 100   | GND       | Reserved     | --  | --        | Signal Ground   | Must be connected to GND |
| 101   | HDP A     | USB Host A   | I/O | VCC3_3    | USB Host A Data Positive  | Leave open               |
| 102   | --        | Reserved     | --  | --        | No Connect; Reserved for future use                             | Leave open               |
| 103   | GND       | USB Host B   | --  | --        | Signal Ground   | Must be connected to GND |
| 104   | --        | Reserved     | --  | --        | No Connect; Reserved for future use                             | Leave open               |
| 105   | HDMB      | USB Host B   | I/O | VCC3_3    | USB Host B Data Negative  | Leave open               |
| 106   | --        | Reserved     | --  | --        | No Connect; Reserved for future use                             | Leave open               |
| 107   | HDPB      | USB Host B   | I/O | VCC3_3    | USB Host B Data Positive  | Leave open               |
| 108   | --        | Reserved     | --  | --        | No Connect; Reserved for future use                             | Leave open               |
| 109   | GND       | Power Supply | --  | --        | Supply Ground   | Must be connected to GND |
| 110   | --        | Reserved     | --  | --        | No Connect; Reserved for future use                             | Leave open               |
| 111   | GND       | Power Supply | --  | --        | Supply Ground   | Must be connected to GND |
| 112   | --        | Reserved     | --  | --        | No Connect; Reserved for future use                             | Leave open               |
| 113   | GND       | Power Supply | --  | --        | Supply Ground   | Must be connected to GND |



| Pin # | Name   | Section      | I/O | Reference | Description       | If unused                |
|-------|--------|--------------|-----|-----------|-------------------|--------------------------|
| 114   | GND    | Power Supply | --  | --        | Supply Ground     | Must be connected to GND |
| 115   | VCC3_3 | Power Supply | --  | --        | 3.3V Module Power | 3.3V must be supplied    |
| 116   | GND    | Power Supply | --  | --        | Supply Ground     | Must be connected to GND |
| 117   | VCC3_3 | Power Supply | --  | --        | 3.3V Module Power | 3.3V must be supplied    |
| 118   | VCC3_3 | Power Supply | --  | --        | 3.3V Module Power | 3.3V must be supplied    |
| 119   | VCC3_3 | Power Supply | --  | --        | 3.3V Module Power | 3.3V must be supplied    |
| 120   | VCC3_3 | Power Supply | --  | --        | 3.3V Module Power | 3.3V must be supplied    |

## 7 MECHANICAL SPECIFICATIONS

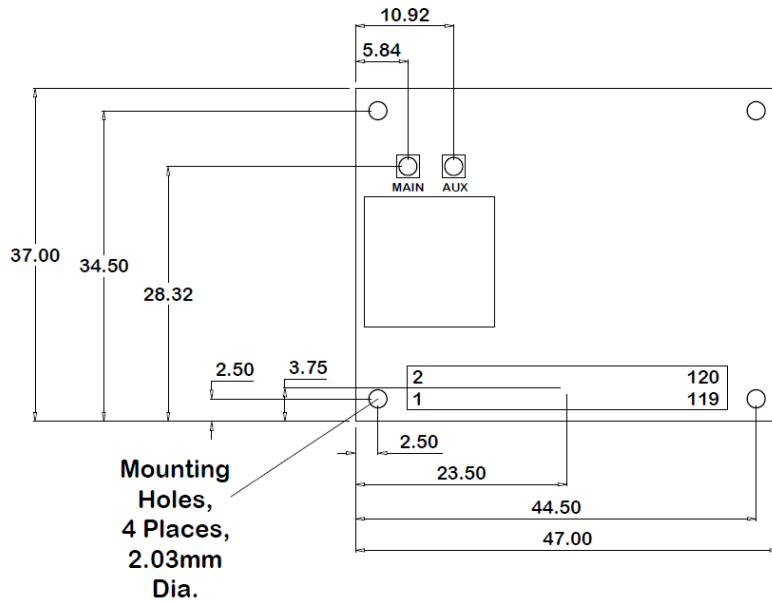

**SDC-WB40NBT Rev 5**  
**Top View**

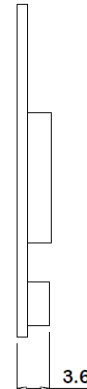

Note: The overall thickness is approx. 4.7mm including parts on reverse side of PCB.

**Side View**

### 7.1 Mounting

The WB40NBT board provides the following: 245046120600829+ CONN RECEPT 120 POS SMD 0.5MM

There are four Kyocera Elco options for mating connectors, each option providing for four different stack heights. Depending on the board to board space required the main board part number is:

| Part Number      | Contacts | B2B  | (mm) | Newark PN |
|------------------|----------|------|------|-----------|
| 145046120630829+ | 120      | Plug | 3.0  | 96M9299   |
| 145046120635829+ | 120      | Plug | 3.5  | 96M9300   |
| 145046120640829+ | 120      | Plug | 4.0  | 96M9301   |
| 145046120645829+ | 120      | Plug | 4.5  | 03M4923   |

The WB40NBT provides four grounded mounting holes located on the corners of the module. One or more of these mounting holes may be used to secure the module to the host device with conductive screws with bushings that correspond to the selected stack height.

## 8 INTEGRATION GUIDELINES

The following is a list of RF layout design guidelines and recommendation when installing a Laird module into your device.

- Do not run antenna cables directly above or directly below the module.
- If there are other radios or transmitters in the device (such as a Bluetooth radio), place the devices as far apart from each other as possible.
- Ensure that there is the maximum allowable spacing separating the antenna connectors on the Laird radio from the antenna. In addition, do not place antennas directly above or directly below the radio.
- Laird recommends the use of a double shielded cable for the connection between the radio and the antenna elements.

## 9 REGULATORY

### 9.1 Certified Antennas

The SDC-WB40NBT was tested to the regulatory standards defined in the “Certifications” section of the Specifications table above. Testing was conducted with the following antennas:

#### Cisco AIR-ANT 4941

- Form Factor: Whip
- Type: Dipole
- Maximum 2.4 GHz Gain: 2.2 dBi
- Tested and Certified 2.4 GHz Transmit Power: 100% of maximum setting (no reduction of power is required in the 2.4 GHz band)

#### Radiall Larson Dipole

- Form Factor: Whip
- Type: Dipole
- Maximum 2.4 GHz Gain: 1.6 dBi (not used during testing)
- Maximum 5 GHz Gain: 5 dBi
- Tested and Certified 5 GHz Transmit Power: 100% of maximum setting (no reduction of power is required in the 5 GHz band)

#### HUBER+SUHNER

- Form Factor: Whip
- Type: Monopole
- Maximum 2.4 GHz Gain: 3dBi
- Maximum 5 GHz Gain: 6.5dBi
- Tested and Certified 2.4 GHz Transmit Power: 100% of maximum setting (no reduction of power is required in the 2.4 GHz band)
- Tested and Certified 5 GHz Transmit Power: 100% of maximum setting (no reduction of power is required in the 5 GHz band)

#### Ethertronics

- Form Factor: Isolated Magnetic Dipole™ (IMD)
- Type: GY Internal Antenna
- Maximum 2.4 GHz Gain: 2.5 dBi

- Maximum 5 GHz Gain: 5 dBi
- Tested and Certified 2.4 GHz Transmit Power: 100% of maximum setting (no reduction of power is required in the 2.4 GHz band)
- Tested and Certified 5 GHz Transmit Power: 100% of maximum setting (no reduction of power is required in the 5 GHz band)

---

**Note:** If the formal test reports for the SDC-WB40NBT show that transmit power was decreased to less than 100% on 2.4 GHz edge channels, Laird will make these transmit power reductions in firmware for the edge channels. Integrators do not need to reduce transmit power on a channel-by-channel basis to comply with band edge regulations.

---

Antennas of differing types and higher gains may be integrated as well. If necessary, with the Summit Manufacturing Utility software utility, OEMs may reduce the transmit power of the SDC-WB40NBT to account for higher antenna gain. In some cases, OEMs may be able to reduce certification efforts by using antennas that are of like type and equal or lesser gain to the above listed antennas.

## 9.2 Documentation Requirements

In order to ensure regulatory compliance, when integrating the SDC-WB40NBT into a host device, it is necessary to meet the documentation requirements set forth by the applicable regulatory agencies. The following sections (FCC, Industry Canada, and European Union) outline the information that may be included in the user's guide and external labels for the host devices into which the SDC-WB40NBT is integrated.

### 9.2.1 FCC

---

**Note:** You must place "Contains FCC ID: TWG-SDCW40NBT" on the host product in such a location that it can be seen by an operator at the time of purchase.

---

#### 9.2.1.1 User's Guide Requirements

As outlined in the Operational Description, the SDC-WB40NBT complies with [FCC Part 15 Rules](#) for a Modular Approval. To leverage Laird's grant, the two conditions below must be met for the host device into which the SDC-WB40NBT is integrated:

1. The antenna is installed with 20 cm maintained between the antenna and users.
2. The transmitter module is not co-located with any other transmitter or antenna that is capable of simultaneous operation.

As long as the two conditions above are met, further *transmitter* testing is typically not required. However, the OEM integrator is still responsible for testing its end-product for any additional compliance requirements required with this module installed, such as (but not limited to) digital device emissions and PC peripheral requirements.

#### **IMPORTANT!**

---

In the event that the two conditions above **cannot be met** (for example certain device configurations or co-location with another transmitter), then the FCC authorization is no longer considered valid and the FCC ID **cannot** be used on the final product. In these circumstances, the OEM integrator will be responsible for re-evaluating the end product (including the transmitter) and obtaining a separate FCC authorization.

---

When using Laird's FCC grant for the SDC-WB40NBT, the integrator must include specific information in the user's guide for the device into which the SDC-WB40NBT is integrated. The integrator must not provide

information to the end user regarding how to install or remove this RF module in the user's manual of the device into which the SDC-WB40NBT is integrated. The following FCC statements must be added in their entirety and without modification into a prominent place in the user's guide for the device into which the SDC-WB40NBT is integrated:

---

**“IMPORTANT NOTE:** To comply with FCC RF exposure compliance requirements, the antenna used for this transmitter must be installed to provide a separation distance of at least 20 cm from all persons and must not be co-located or operating in conjunction with any other antenna or transmitter.”

**Federal Communication Commission Interference Statement**

This equipment has been tested and found to comply with the limits for a Class B digital device, pursuant to Part 15 of the FCC Rules. These limits are designed to provide reasonable protection against harmful interference in a residential installation. This equipment generates, uses, and can radiate radio frequency energy and, if not installed and used in accordance with the instructions, may cause harmful interference to radio communications. However, there is no guarantee that interference will not occur in a particular installation. If this equipment does cause harmful interference to radio or television reception, which can be determined by turning the equipment off and on, the user is encouraged to try to correct the interference by one of the following measures:

1. Reorient or relocate the receiving antenna.
2. Increase the separation between the equipment and receiver.
3. Connect the equipment into an outlet on a circuit different from that to which the receiver is connected.
4. Consult the dealer or an experienced radio/TV technician for help.

**FCC Caution:** Any changes or modifications not expressly approved by the party responsible for compliance could void the user's authority to operate this equipment.

This device complies with Part 15 of the FCC Rules. Operation is subject to the following two conditions: (1) This device may not cause harmful interference, and (2) this device must accept any interference received, including interference that may cause undesired operation.

**IMPORTANT NOTE:** FCC Radiation Exposure Statement:

This equipment complies with FCC radiation exposure limits set forth for an uncontrolled environment. This equipment should be installed and operated with minimum distance 20cm between the radiator & your body.

## 9.2.2 Industry Canada

**Note:** You must place “Contains IC ID: 6616A-SDCWB40NBT” on the host product in such a location that it can be seen by an operator at the time of purchase.

### 9.2.2.1 User's Guide Requirements (for Model # SDC-WB40NBT)

#### **RF Radiation Hazard Warning**

To ensure compliance with FCC and Industry Canada RF exposure requirements, this device must be installed in a location where the antennas of the device will have a minimum distance of at least 20 cm from all persons. Using higher gain antennas and types of antennas not certified for use with this product is not allowed. The device shall not be co-located with another transmitter.

Installez l'appareil en veillant à conserver une distance d'au moins 20 cm entre les éléments rayonnants et les personnes. Cet avertissement de sécurité est conforme aux limites d'exposition définies par la norme CNR-102 at relative aux fréquences radio.

**Maximum Antenna Gain – If the integrator configures the device such that the antenna is detectable from the host product.**

This radio transmitter (IC ID: 6616A-SDCWB40NBT) has been approved by Industry Canada to operate with the antenna types listed below with the maximum permissible gain and required antenna impedance for each antenna type indicated. Antenna types not included in this list, having a gain greater than the maximum gain indicated for that type, are strictly prohibited for use with this device.

Le présent émetteur radio (IC ID: 6616A-SDCWB40NBT) a été approuvé par Industrie Canada pour fonctionner avec les types d'antenne énumérés ci-dessous et ayant un gain admissible maximal et l'impédance requise pour chaque type d'antenne. Les types d'antenne non inclus dans cette liste, ou dont le gain est supérieur au gain maximal indiqué, sont strictement interdits pour l'exploitation de l'émetteur.

Under Industry Canada regulations, this radio transmitter may only operate using an antenna of a type and maximum (or lesser) gain approved for the transmitter by Industry Canada. To reduce potential radio interference to other users, the antenna type and its gain should be so chosen that the equivalent isotropically radiated power (e.i.r.p.) is not more than that necessary for successful communication.

Conformément à la réglementation d'Industrie Canada, le présent émetteur radio peut fonctionner avec une antenne d'un type et d'un gain maximal (ou inférieur) approuvé pour l'émetteur par Industrie Canada. Dans le but de réduire les risques de brouillage radioélectrique à l'intention des autres utilisateurs, il faut choisir le type d'antenne et son gain de sorte que la puissance isotrope rayonnée équivalente (p.i.r.e.) ne dépasse pas l'intensité nécessaire à l'établissement d'une communication satisfaisante.

This device complies with Industry Canada licence-exempt RSS standard(s). Operation is subject to the following two conditions: (1) this device may not cause interference, and (2) this device must accept any interference, including interference that may cause undesired operation of the device.

Le présent appareil est conforme aux CNR d'Industrie Canada applicables aux appareils radio exempts de licence. L'exploitation est autorisée aux deux conditions suivantes : (1) l'appareil ne doit pas produire de brouillage, et (2) l'utilisateur de l'appareil doit accepter tout brouillage radioélectrique subi, même si le brouillage est susceptible d'en compromettre le fonctionnement.

### 9.2.3 European Union

#### 9.2.3.1 Declaration of Conformity

|                            |  |   |
|----------------------------|--|---|
| <b>Manufacturer</b>        | Laird  |  |
| <b>Products</b>            | WB40NBT  |   |
| <b>Product Description</b> | 802.11 a/b/g/n Enterprise Wi-Fi + Bluetooth module |   |
| <b>EU Directives</b>       | 2014/53/EU – Radio Equipment Directive (RED)       |   |

**Reference standards used for presumption of conformity:**

| Article Number | Requirement   | Reference standard(s)  |
|----------------|---|--|
| 3.1a           | Low voltage equipment safety  | EN 60950-1:2006 +A11:2009 +A1:2010<br>+A12:2011 +A2:2013                         |
|                | RF Exposure   | EN 62311:2008<br>EN 50385:2002   |
| 3.1b           | Protection requirements with respect to electromagnetic compatibility | EN 301 489-1 v2.2.0 (2017-03)<br>EN 301 489-17 v3.2.0 (2017-03)<br>EN 55022:2010 |
| 3.2            | Protection requirements – Electromagnetic compatibility               | EN 300 328 v2.1.1 (2016-11)<br>EN 301 893 v2.1.1 (2017-05)                       |

**Declaration:**

We, Laird, declare under our sole responsibility that the essential radio test suites have been carried out and that the above product to which this declaration relates is in conformity with all the applicable essential requirements of Article 3 of the EU Radio Equipment Directive 2014/53/EU, when used for its intended purpose.

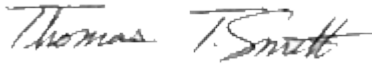
|                                 |   |
|---------------------------------|---|
| Place of Issue:                 | Laird<br>W66N220 Commerce Court, Cedarburg, WI 53012 USA<br>tel: +1-262-375-4400 fax: +1-262-364-2649 |
| Date of Issue:                  | June 2017   |
| Name of Authorized Person:      | Thomas T Smith, Director of EMC Compliance  |
| Signature of Authorized Person: |                    |

#### 9.2.3.2 User’s Guide Requirements

The integrator must include specific information in the user’s guide for the device into which the SDC-WB40NBT is integrated. In addition to the required FCC and IC statements outlined above, the following R&TTE statements must be added in their entirety and without modification into a prominent place in the user’s guide for the device into which the SDC-WB40NBT is integrated:

This device complies with the essential requirements of the EU Radio Equipment Directive 2014/53/EU. The following test methods have been applied in order to prove presumption of conformity with the essential requirements of the EU Radio Equipment Directive 2014/53/EU:

- **EN 60950-1:2006 +A11:2009 +A1:2010 +A12:2011 +A2:2013**  
Safety of Information Technology Equipment
- **EN 300 328 v2.1.1 (2016-11)**  
Electromagnetic compatibility and Radio Spectrum Matters (ERM); Wideband Transmission systems; Data transmission equipment operating in the 2,4 GHz ISM band and using spread spectrum modulation techniques; Harmonized EN covering essential requirements under article 3.2 of the R&TTE Directive
- **EN 301 489-1 v2.2.0 (2017-03)**  
Electromagnetic compatibility and Radio Spectrum Matters (ERM); ElectroMagnetic Compatibility (EMC) standard for radio equipment and services; Part 1: Common technical requirements
- **EN 301 489-17 v3.2.0 (2017-03)**  
Electromagnetic compatibility and Radio Spectrum Matters (ERM); ElectroMagnetic Compatibility (EMC) standard for radio equipment and services; Part 17: Specific conditions for 2,4 GHz wideband transmission systems and 5 GHz high performance RLAN equipment
- **EN 301 893 v2.1.1 (2017-05)**  
Electromagnetic compatibility and Radio Spectrum Matters (ERM); Broadband Radio Access Networks (BRAN); Specific conditions for 5 GHz high performance RLAN equipment
- **2011/65/EU (RoHS)**  
Declaration of Compliance – EU Directive 2011/65/EU; Reduction of Hazardous Substances (RoHS)

This device is a 2.4 GHz wideband transmission system (transceiver), intended for use in all EU member states and EFTA countries, except in France and Italy where restrictive use applies.

In Italy the end-user should apply for a license at the national spectrum authorities in order to obtain authorization to use the device for setting up outdoor radio links and/or for supplying public access to telecommunications and/or network services.

This device may not be used for setting up outdoor radio links in France and in some areas the RF output power may be limited to 10 mW EIRP in the frequency range of 2454 – 2483.5 MHz. For detailed information the end-user should contact the national spectrum authority in France.

|                            |  |
|----------------------------|--|
| <b>cs</b> Česky [Czech]    | <i>[Jméno výrobce]</i> tímto prohlašuje, že tento <i>[typ zařízení]</i> je ve shodě se základními požadavky a dalšími příslušnými ustanoveními směrnice 1999/5/ES.   |
| <b>da</b> Dansk [Danish]   | Undertegnede <i>[fabrikantens navn]</i> erklærer herved, at følgende udstyr <i>[udstyrets typebetegnelse]</i> overholder de væsentlige krav og øvrige relevante krav i direktiv 1999/5/EF.   |
| <b>de</b> Deutsch [German] | Hiermit erkläre <i>[Name des Herstellers]</i> , dass sich das Gerät <i>[Gerätetyp]</i> in Übereinstimmung mit den grundlegenden Anforderungen und den übrigen einschlägigen Bestimmungen der Richtlinie 1999/5/EG befindet.          |
| <b>et</b> Eesti [Estonian] | Käesolevaga kinnitab <i>[tootja nimi = name of manufacturer]</i> seadme <i>[seadme tüüp = type of equipment]</i> vastavust direktiivi 1999/5/EÜ põhinõuetele ja nimetatud direktiivist tulenevatele teistele asjakohastele sätetele. |
| <b>en</b> English          | Hereby, <i>[name of manufacturer]</i> , declares that this <i>[type of equipment]</i> is in compliance with the essential requirements and other relevant provisions of Directive 1999/5/EC.   |



|                                  |  |
|----------------------------------|--|
| <b>es</b> Español [Spanish]      | Por medio de la presente [ <i>nombre del fabricante</i> ] declara que el [ <i>clase de equipo</i> ] cumple con los requisitos esenciales y cualesquiera otras disposiciones aplicables o exigibles de la Directiva 1999/5/CE.            |
| <b>el</b> Ελληνική [Greek]       | ΜΕ ΤΗΝ ΠΑΡΟΥΣΑ [ <i>name of manufacturer</i> ] ΔΗΛΩΝΕΙ ΟΤΙ [ <i>type of equipment</i> ] ΣΥΜΜΟΡΦΩΝΕΤΑΙ ΠΡΟΣ ΤΙΣ ΟΥΣΙΩΔΕΙΣ ΑΠΑΙΤΗΣΕΙΣ ΚΑΙ ΤΙΣ ΛΟΙΠΕΣ ΣΧΕΤΙΚΕΣ ΔΙΑΤΑΞΕΙΣ ΤΗΣ ΟΔΗΓΙΑΣ 1999/5/ΕΚ.   |
| <b>fr</b> Français [French]      | Par la présente [ <i>nom du fabricant</i> ] déclare que l'appareil [ <i>type d'appareil</i> ] est conforme aux exigences essentielles et aux autres dispositions pertinentes de la directive 1999/5/CE.                                  |
| <b>it</b> Italiano [Italian]     | Con la presente [ <i>nome del costruttore</i> ] dichiara che questo [ <i>tipo di apparecchio</i> ] è conforme ai requisiti essenziali ed alle altre disposizioni pertinenti stabilite dalla direttiva 1999/5/CE.                         |
| <b>Latviski [Latvian]</b>        | Aršo [ <i>name of manufacturer / izgatavotājanosaukums</i> ] deklarē, ka [ <i>type of equipment / iekārtas tips</i> ] atbilst Direktīvas 1999/5/EK būtiskajām prasībām un citiemar to saistītajiem noteikumiem.                          |
| <b>Lietuvių [Lithuanian]</b>     | Šiuo [ <i>manufacturer name</i> ] deklaruoja, kad šis [ <i>equipment type</i> ] atitinka esminius reikalavimus ir kitas 1999/5/EB Direktyvos nuostatas.  |
| <b>nl</b> Nederlands [Dutch]     | Hierbij verklaart [ <i>naam van de fabrikant</i> ] dat het toestel [ <i>type van toestel</i> ] in overeenstemming is met de essentiële eisen en de andere relevante bepalingen van richtlijn 1999/5/EG.                                  |
| <b>mt</b> Malti [Maltese]        | Hawnhekk, [ <i>isem tal-manifattur</i> ], jiddikjara li dan [ <i>il-mudal tal-prodott</i> ] jikkonforma mal-<br>ħtiġijiet essenzjali u ma provvedimenti oħrajn rilevanti li hemm fid-Dirrettiva 1999/5/EC.                               |
| <b>hu</b> Magyar [Hungarian]     | Alulírott, [ <i>gyártó neve</i> ] nyilatkozom, hogy a [ <i>... típus</i> ] megfelel a vonatkozó alapvető követelményeknek és az 1999/5/EC irányelv egyéb előírásainak.   |
| <b>pl</b> Polski [Polish]        | Niniejszym [ <i>nazwa producenta</i> ] oświadczam, że [ <i>nazwa wyrobu</i> ] jest zgodny z zasadniczymi wymogami oraz pozostałymi stosownymi postanowieniami Dyrektywy 1999/5/EC.   |
| <b>pt</b> Português [Portuguese] | [ <i>Nome do fabricante</i> ] declara que este [ <i>tipo de equipamento</i> ] está conforme com os requisitos essenciais e outras disposições da Directiva 1999/5/CE.  |
| <b>sl</b> Slovensko [Slovenian]  | [ <i>Ime proizvajalca</i> ] izjavlja, da je ta [ <i>tip opreme</i> ] v skladu z bistvenimi zahtevami in ostalimi relevantnimi določili direktive 1999/5/ES.  |
| <b>Slovensky [Slovak]</b>        | [ <i>Menovýrobcu</i> ] týmto vyhlasuje, že [ <i>typzariadenia</i> ] spĺňa základné požiadavky a všetky príslušné ustanovenia Smernice 1999/5/ES.   |
| <b>fi</b> Suomi [Finnish]        | [ <i>Valmistaja = manufacturer</i> ] vakuuttaa täten että [ <i>type of equipment = laitteen tyyppimerkintä</i> ] tyyppinen laite on direktiivin 1999/5/EY oleellisten vaatimusten ja sitä koskevien direktiivin muiden ehtojen mukainen. |
| <b>sv</b> Svenska [Swedish]      | Härmed intygar [ <i>företag</i> ] att denna [ <i>utrustningstyp</i> ] står i överensstämmelse med de väsentliga egenskapskrav och övriga relevanta bestämmelser som framgår av direktiv 1999/5/EG.                                       |