

MARKETING SALES DRAWING

DIMENSIONS IN INCHES - DO NOT SCALE THIS DRAWING  
 DIMENSIONS IN METRIC [ ]

Electrical Testing  
 per Tusonix standard  
 test plans and Mil-Std-202  
 Test Methods.

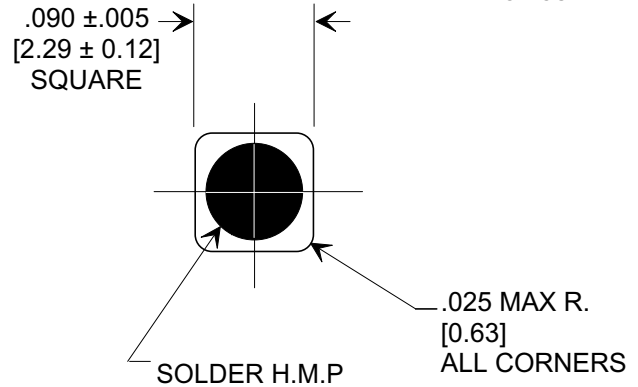
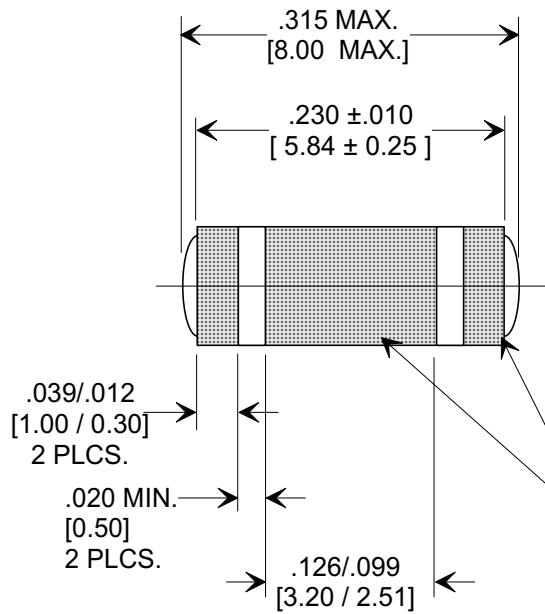
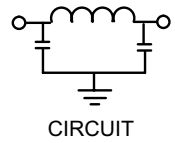
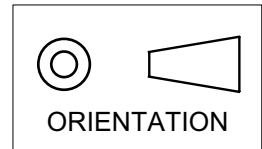

ELECTRODE  
 TERMINATION  
 SEE NOTE 5

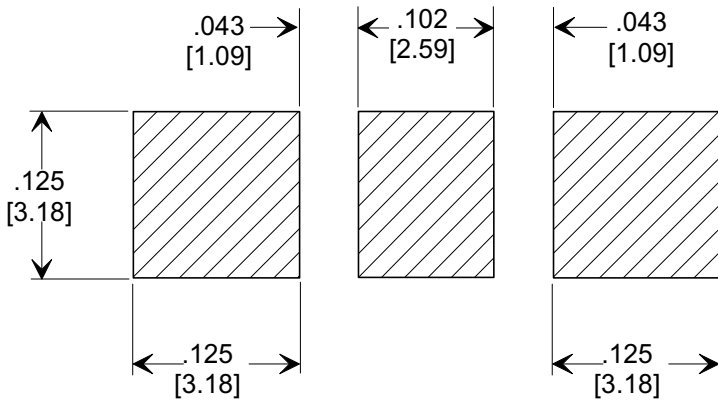

SUGGESTED  
 MOUNTING PATTERN

1. INDUCTANCE TO BE 0.1 H MINIMUM.
2. PACKAGE: BULK OR BLISTER TAPE TO IEC-60286-3 TYPE II AND EIA-481-A.
3. TUSONIX STANDARD PART NUMBER: 4700-008. TUSONIX RoHS COMPLIANT PART NUMBER: 4700-008 LF. CUSTOMER MUST SPECIFY STANDARD OR RoHS PART NUMBER WHEN ORDERING.
4. PART MARKING: STANDARD PART: NO MARKING. RoHS PART: LABELED ON PACKAGING ONLY.
5. ELECTRODE TERMINATION: STANDARD 60/40 SOLDER; RoHS COMPLIANT - MATTE TIN.

CAP.	TOLERANCE	WVDC 85°C	TEST VOLTAGE	I.R.MIN. @ 100 (VDC.)	IDC	TYPICAL NO LOAD INSERTION LOSS dB AT 25°C PER MIL-STD-220		
						10 MHZ	100 MHZ	1 GHZ
4000 pF	+80% / -20%	100	300 VDC	10 G	10 A	13	52	70

REVISION RECORD	0	Original Release C.O.
	12	REVISED DWG. DRAWING MADE FOR EACH VAR. S.M. 02-13-03
	13	REVISED DRAWING. S.M. 06-20-03
	14	ADDED NOTES 3-5. S.M. 06-13-05
	14	20050607-5-03

--TOLERANCES-- Unless Otherwise Specified		Title <b>SURFACE MOUNT SQUARE STYLE PI FILTER</b>	
DECIMAL ± .005 [0.13]		Drawn FG 9-9-94	Scale 7 X
ANGLES ±		Approved NV 9-9-94	
<b>TUSONIX</b> TUCSON, ARIZONA		<b>A</b>	<b>4700-008</b>

X-2015 Rev-0