

Fully Integrated Analog Front-End Dual Receiver Base Unit for 27-MHz Wireless Mouse and Keyboard Systems

FEATURES

- 23 Discrete Components Integrated into One Chip
 - Only External Components are Bypass and Filter Capacitors, and One Crystal
- RF Tuner, Mixer, Transistors, Passives, Coils, and Ceramic Filter Functionality All on One Chip
- Integrated Phase Locked Loop
- 8 User-Selectable Frequencies
 - Each Channel (Mouse and Keyboard) Can Independently Select Any of the Available Frequencies
- Internally Generated 6-MHz Clock to Drive USB Microcontroller

- High Data Throughput Rate
 - 5-kHz Square Wave Simultaneously per Channel
 - 10 kbps Miller Encoded Data
- I²C Control Interface
- Received Signal Strength Indicator
- 5-V Supply
- Available in 28-Pin TSSOP (PW) Package

APPLICATIONS

- 27-MHz Wireless Mouse and Keyboard Systems
- Human Interface Devices
- Wireless Control
- Remote Control Toys
- Wireless Headset
- Remote instrumentation

DESCRIPTION

The TRF7900A is a dual integrated RF transceiver designed for human-interface devices (HID). Operating at 27 MHz, it integrates multiple components (PLL, RF mixer, simulated SAW filter, tuning circuit, and miscellaneous passive components) to provide frequency selection from 8 discrete channels. This integration lowers component, manufacturing and system costs.

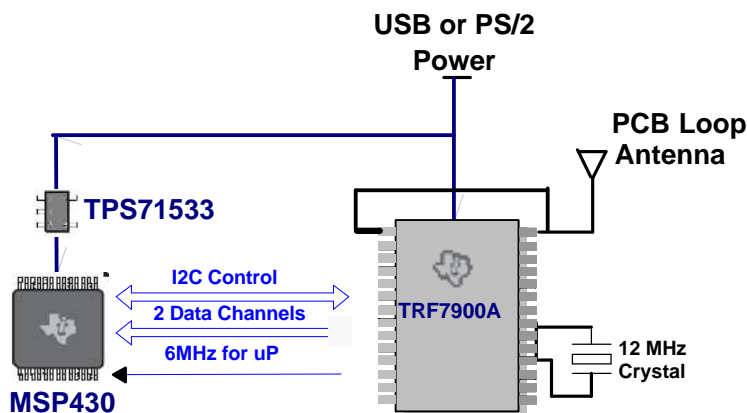

The TRF7900A simplifies system design by reducing system component count and manual circuit tuning. By integrating the PLL, SAW filter, and RF mixer, the TRF7900A eliminates the manual tuning of RLC circuits required in traditional implementations.



Please be aware that an important notice concerning availability, standard warranty, and use in critical applications of Texas Instruments semiconductor products and disclaimers thereto appears at the end of this data sheet.

The receiver also generates 8 frequencies that can be programmatically selected via the I²C interface bus for both the mouse channel and/or the keyboard channel. Another 6-MHz clock is internally generated to clock the USB microcontroller; this enables a single crystal to be used to supply the clock needs for the receiver channels and the microcontroller.

The optimized receiver design enables simultaneous reception on both parallel channels up to 5 kHz (10 kbps Miller encoding) per channel. A receive strength signal indicator register can be read via the I²C bus to determine the signal strength. Correlating the RSSI reading to the packet error rate enables the controller to diagnose the signal and understand the user condition.

ORDERING INFORMATION

PACKAGED DEVICES	PACKAGE TYPE	TRANSPORT MEDIA, QUANTITY
TRF7900APW	TSSOP - 28	Rails, 50
TRF7900APWR	TSSOP - 28	Tape and Reel, 2000

ABSOLUTE MAXIMUM RATINGS

over operating free-air temperature range (unless otherwise noted)

		VALUE	UNIT ⁽¹⁾
V _{S-} to V _{S+}	Supply voltage	5.5	V
V _I	Input voltage	±V _S ± 0.5	V
V _{ID}	Differential input voltage	±2	V
	Continuous power dissipation	See Dissipation Rating Table	
T _J	Maximum junction temperature, any condition ⁽²⁾	150	°C
T _J	Maximum junction temperature, continuous operation, long term reliability ⁽³⁾	125	°C
T _{stg}	Storage temperature range	-65 to 150	°C
	Lead temperature 1,6 mm (1/16 inch) from case for 10 seconds	300	°C
	ESD ratings: Human Body Model	4000	V
	ESD ratings: Charged Device Model	1500	V
	ESD ratings: Machine Model	200	V

- (1) The absolute maximum ratings under any condition is limited by the constraints of the silicon process. Stresses above these ratings may cause permanent damage. Exposure to absolute maximum conditions for extended periods may degrade device reliability. These are stress ratings only, and functional operation of the device at these or any other conditions beyond those specified is not implied.
- (2) The maximum junction temperature for continuous operation is limited by package constraints. Operation above this temperature may result in reduced reliability and/or lifetime of the device.

DISSIPATION RATINGS

PACKAGE	θ _{JC}	θ _{JA} ⁽¹⁾	POWER RATING ⁽²⁾	
			T _A ≤ 25°C	T _A = 85°C
PW (28)	13.7	56.5	1.77 W	708 mW

- (1) This data was taken using the JEDEC standard high-K test PCB.
- (2) Power rating is determined with a junction temperature of 125°C. This is the point where distortion starts to substantially increase. Thermal management of the final PCB should strive to keep the junction temperature at or below 125°C for best performance and long term reliability.

RECOMMENDED OPERATING CONDITIONS

over operating free-air temperature range (unless otherwise noted)

		MIN	NOM	MAX	UNIT
V_{S-} to V_{S+}	Supply voltage, analog	4.0		5.5	V

ELECTRICAL CHARACTERISTICS
 $V_S = 5\text{ V}$, $T_A = 25^\circ\text{C}$ (unless otherwise noted)

PARAMETER		TEST CONDITIONS	MIN	TYP	MAX	UNIT	
I_O	Output current		100		100	mA	
RF Specifications							
	Precision of required external 12-MHz crystal				50	ppm	
	Channel spacing			50		kHz	
	Communication spacing			26.995		MHz	
				27.045		MHz	
				27.095		MHz	
				27.145		MHz	
				27.195		MHz	
				27.295		MHz	
			Optional channel		27.245		MHz
			Optional channel		26.945		MHz
	Antenna Input Resistance	DC Differential		<100		k Ω	
		27 MHz		5		k Ω	
R_O	Output resistance, Out_1 and Out_2			1.2		k Ω	

PW (R-PDSO-G28)

PLASTIC SMALL OUTLINE

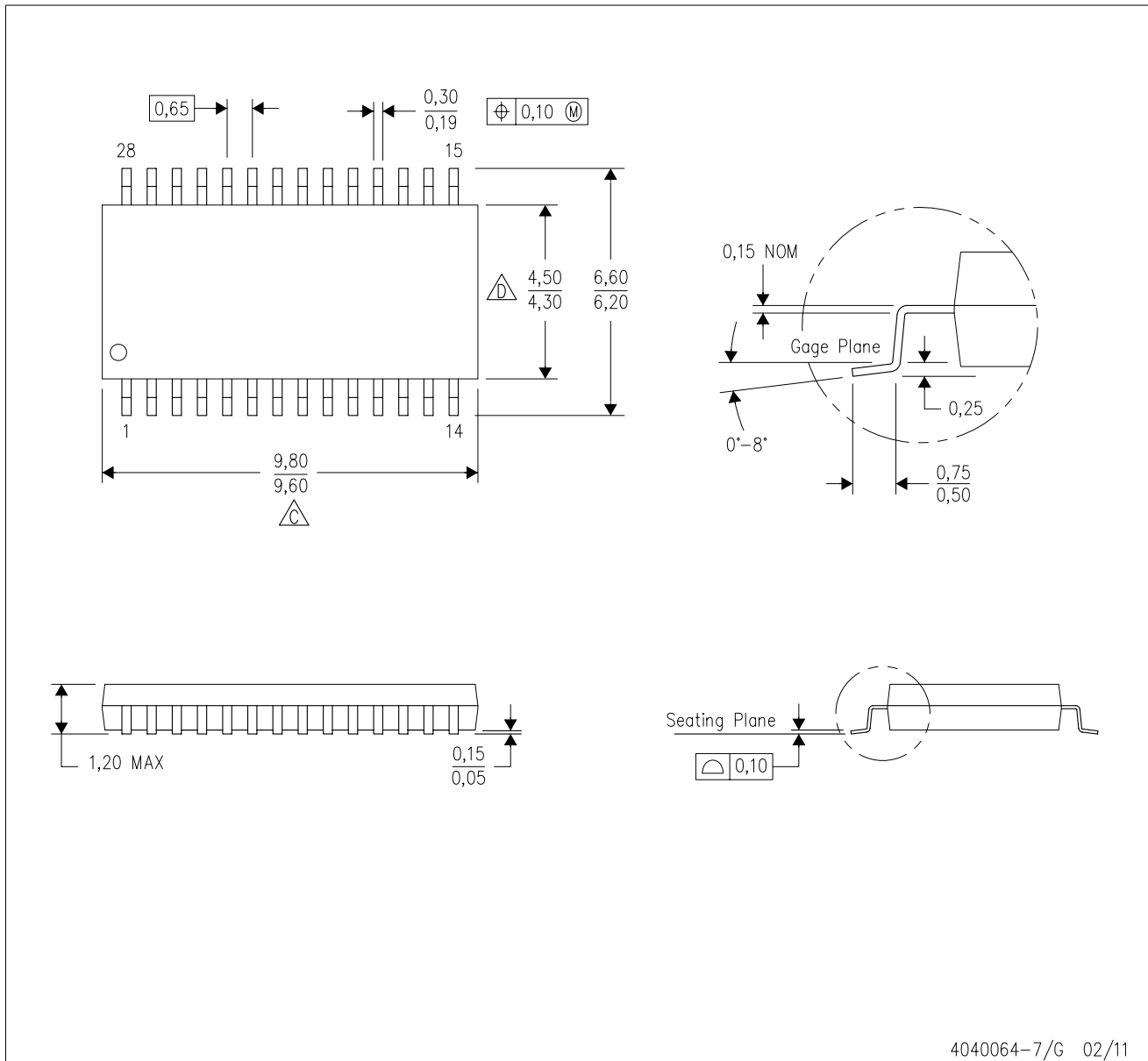

4040064-7/G 02/11

- NOTES:
- A. All linear dimensions are in millimeters. Dimensioning and tolerancing per ASME Y14.5M-1994.
 - B. This drawing is subject to change without notice.
 - C. Body length does not include mold flash, protrusions, or gate burrs. Mold flash, protrusions, or gate burrs shall not exceed 0,15 each side.
 - D. Body width does not include interlead flash. Interlead flash shall not exceed 0,25 each side.
 - E. Falls within JEDEC MO-153

IMPORTANT NOTICE FOR TI DESIGN INFORMATION AND RESOURCES

Texas Instruments Incorporated ("TI") technical, application or other design advice, services or information, including, but not limited to, reference designs and materials relating to evaluation modules, (collectively, "TI Resources") are intended to assist designers who are developing applications that incorporate TI products; by downloading, accessing or using any particular TI Resource in any way, you (individually or, if you are acting on behalf of a company, your company) agree to use it solely for this purpose and subject to the terms of this Notice.

TI's provision of TI Resources does not expand or otherwise alter TI's applicable published warranties or warranty disclaimers for TI products, and no additional obligations or liabilities arise from TI providing such TI Resources. TI reserves the right to make corrections, enhancements, improvements and other changes to its TI Resources.

You understand and agree that you remain responsible for using your independent analysis, evaluation and judgment in designing your applications and that you have full and exclusive responsibility to assure the safety of your applications and compliance of your applications (and of all TI products used in or for your applications) with all applicable regulations, laws and other applicable requirements. You represent that, with respect to your applications, you have all the necessary expertise to create and implement safeguards that (1) anticipate dangerous consequences of failures, (2) monitor failures and their consequences, and (3) lessen the likelihood of failures that might cause harm and take appropriate actions. You agree that prior to using or distributing any applications that include TI products, you will thoroughly test such applications and the functionality of such TI products as used in such applications. TI has not conducted any testing other than that specifically described in the published documentation for a particular TI Resource.

You are authorized to use, copy and modify any individual TI Resource only in connection with the development of applications that include the TI product(s) identified in such TI Resource. NO OTHER LICENSE, EXPRESS OR IMPLIED, BY ESTOPPEL OR OTHERWISE TO ANY OTHER TI INTELLECTUAL PROPERTY RIGHT, AND NO LICENSE TO ANY TECHNOLOGY OR INTELLECTUAL PROPERTY RIGHT OF TI OR ANY THIRD PARTY IS GRANTED HEREIN, including but not limited to any patent right, copyright, mask work right, or other intellectual property right relating to any combination, machine, or process in which TI products or services are used. Information regarding or referencing third-party products or services does not constitute a license to use such products or services, or a warranty or endorsement thereof. Use of TI Resources may require a license from a third party under the patents or other intellectual property of the third party, or a license from TI under the patents or other intellectual property of TI.

TI RESOURCES ARE PROVIDED "AS IS" AND WITH ALL FAULTS. TI DISCLAIMS ALL OTHER WARRANTIES OR REPRESENTATIONS, EXPRESS OR IMPLIED, REGARDING TI RESOURCES OR USE THEREOF, INCLUDING BUT NOT LIMITED TO ACCURACY OR COMPLETENESS, TITLE, ANY EPIDEMIC FAILURE WARRANTY AND ANY IMPLIED WARRANTIES OF MERCHANTABILITY, FITNESS FOR A PARTICULAR PURPOSE, AND NON-INFRINGEMENT OF ANY THIRD PARTY INTELLECTUAL PROPERTY RIGHTS.

TI SHALL NOT BE LIABLE FOR AND SHALL NOT DEFEND OR INDEMNIFY YOU AGAINST ANY CLAIM, INCLUDING BUT NOT LIMITED TO ANY INFRINGEMENT CLAIM THAT RELATES TO OR IS BASED ON ANY COMBINATION OF PRODUCTS EVEN IF DESCRIBED IN TI RESOURCES OR OTHERWISE. IN NO EVENT SHALL TI BE LIABLE FOR ANY ACTUAL, DIRECT, SPECIAL, COLLATERAL, INDIRECT, PUNITIVE, INCIDENTAL, CONSEQUENTIAL OR EXEMPLARY DAMAGES IN CONNECTION WITH OR ARISING OUT OF TI RESOURCES OR USE THEREOF, AND REGARDLESS OF WHETHER TI HAS BEEN ADVISED OF THE POSSIBILITY OF SUCH DAMAGES.

You agree to fully indemnify TI and its representatives against any damages, costs, losses, and/or liabilities arising out of your non-compliance with the terms and provisions of this Notice.

This Notice applies to TI Resources. Additional terms apply to the use and purchase of certain types of materials, TI products and services. These include; without limitation, TI's standard terms for semiconductor products (<http://www.ti.com/sc/docs/stdterms.htm>), [evaluation modules](#), and [samples](http://www.ti.com/sc/docs/sampterm.htm) (<http://www.ti.com/sc/docs/sampterm.htm>).

Mailing Address: Texas Instruments, Post Office Box 655303, Dallas, Texas 75265
Copyright © 2017, Texas Instruments Incorporated