

LOC	DIST	REVISIONS			
P	LTR	DESCRIPTION	DATE	DWN	APVD
ES	-	B	RELEASED PER ECR-07-023182	15OCT2007	A.S S.Y
		B2	ADDED NEW DASH NUMBER	12NOV2008	TY SY
		B3	ADDED HALOGEN FREE LOGO	20NOV2008	TY SY
		B4	REVISE (ECO-19-002267)	21FEB2019	K.G W.H

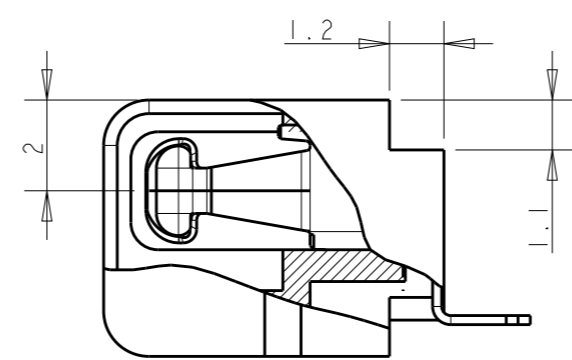

- 1 MATERIAL
HOUSING: THERMOPLASTIC RESIN, UL94V-0, BLACK
CONTACT: COPPER ALLOY
- 2 FINISH
CONTACT: NICKEL ALL OVER UNDERPLATING
GOLD PLATING AT CONTACT AREA
TIN PLATING AT SOLDER AREA
- 3 DATE CODE: 7 DIGIT NUMBER.

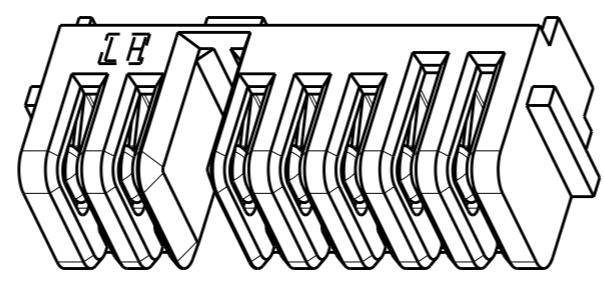
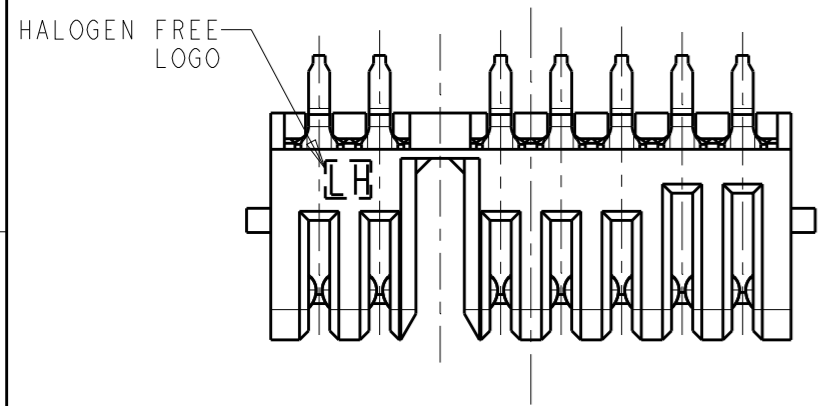
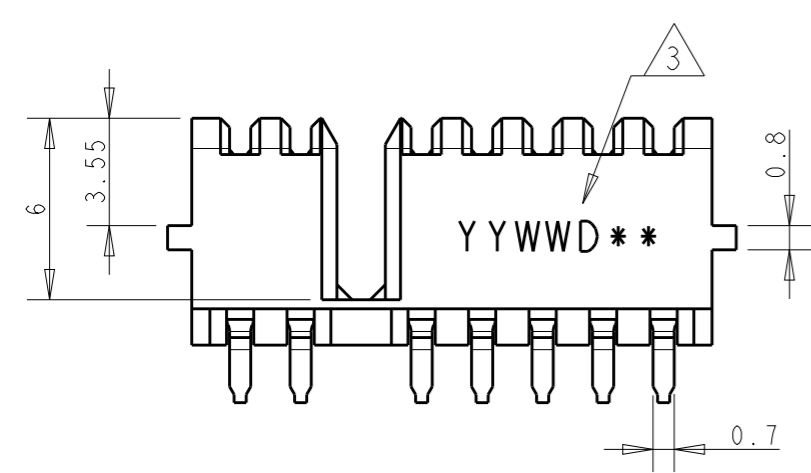
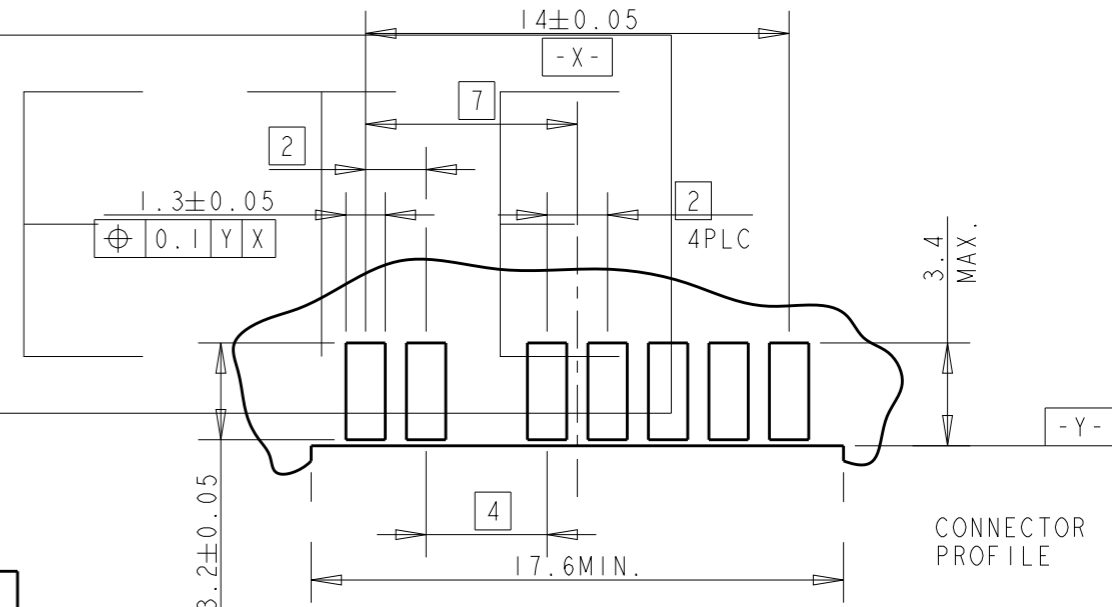
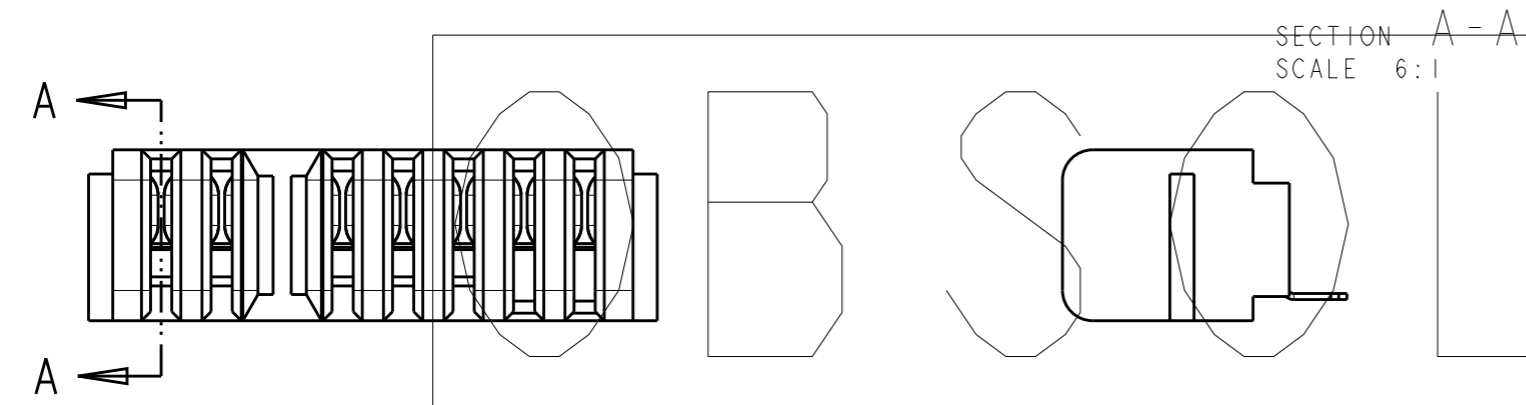

THIS PRINT IS
PRELIMINARY
 UNQUALIFIED PRODUCT
 CONTACT PRODUCT ENGINEERING
 BEFORE USING THIS PRINT

REFERENCE PCB LAYOUT
 PCB THICKNESS 0.8~1.2
 (VIEW FROM CONNECTOR MOUNTING SIDE)

THERMOPLASTIC RESIN (HALOGEN FREE)	I-1932008-1
THERMOPLASTIC RESIN	1932008-1
HOUSING MATERIAL	P/N

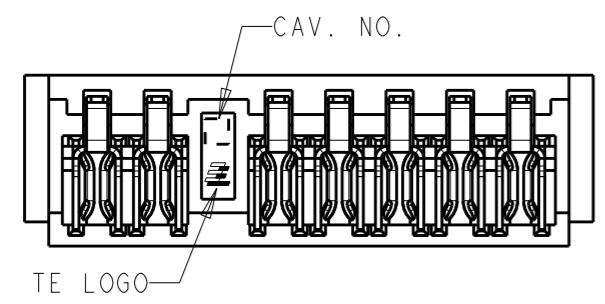

DIMENSIONS: mm		TOLERANCES UNLESS OTHERWISE SPECIFIED:	
		0 PLC	±-
		1 PLC	±0.3
		2 PLC	±0.3
		3 PLC	±0.3
		4 PLC	±-
		ANGLES	±-
MATERIAL		FINISH	
1		2	

DWN	29APR2007	Tyco Electronics Corporation Shanghai P.R.CHINA 200233	
CHK	29APR2007		
APVD	29APR2007		
PRODUCT SPEC	108-78292		
APPLICATION SPEC	-	NAME	RECEPTACLE ASSEMBLY 2.0mm PITCH 7POS. BATTERY CONNECTOR
WEIGHT	0.87g	SIZE	A3
CUSTOMER DRAWING		CAGE CODE	00779
		DRAWING NO	1932008
		RESTRICTED TO	
		SCALE	7:1
		SHEET	1 OF 2
		REV	B4

4

3

2

1

THIS DRAWING IS UNPUBLISHED. RELEASED FOR PUBLICATION 20
 © COPYRIGHT 20 BY TYCO ELECTRONICS CORPORATION. ALL RIGHTS RESERVED.

LOC	DIST	REVISIONS			
P	LTR	DESCRIPTION	DATE	DWN	APVD
ES	-	SEE SHEET 1	-	-	-

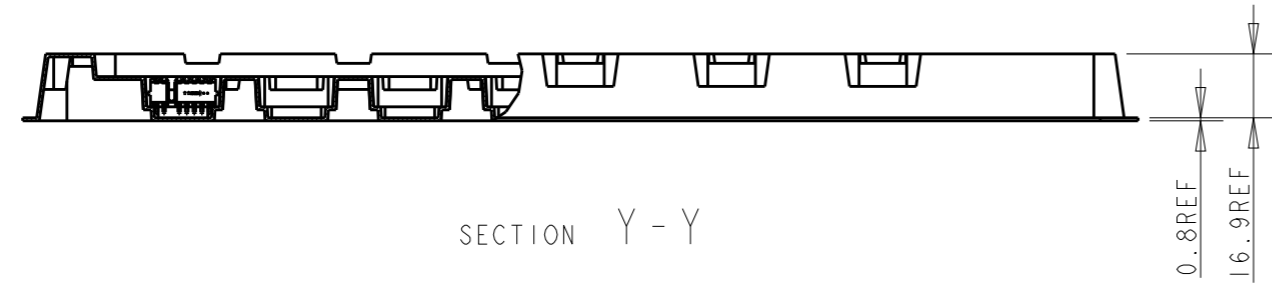
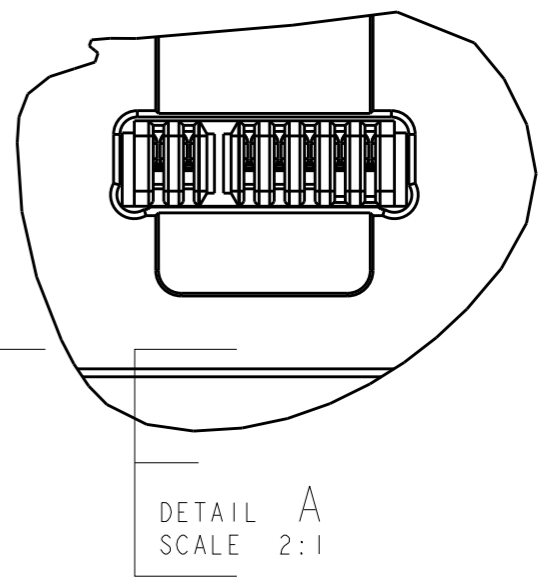
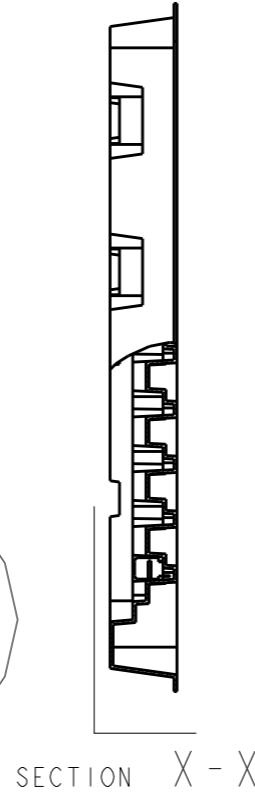
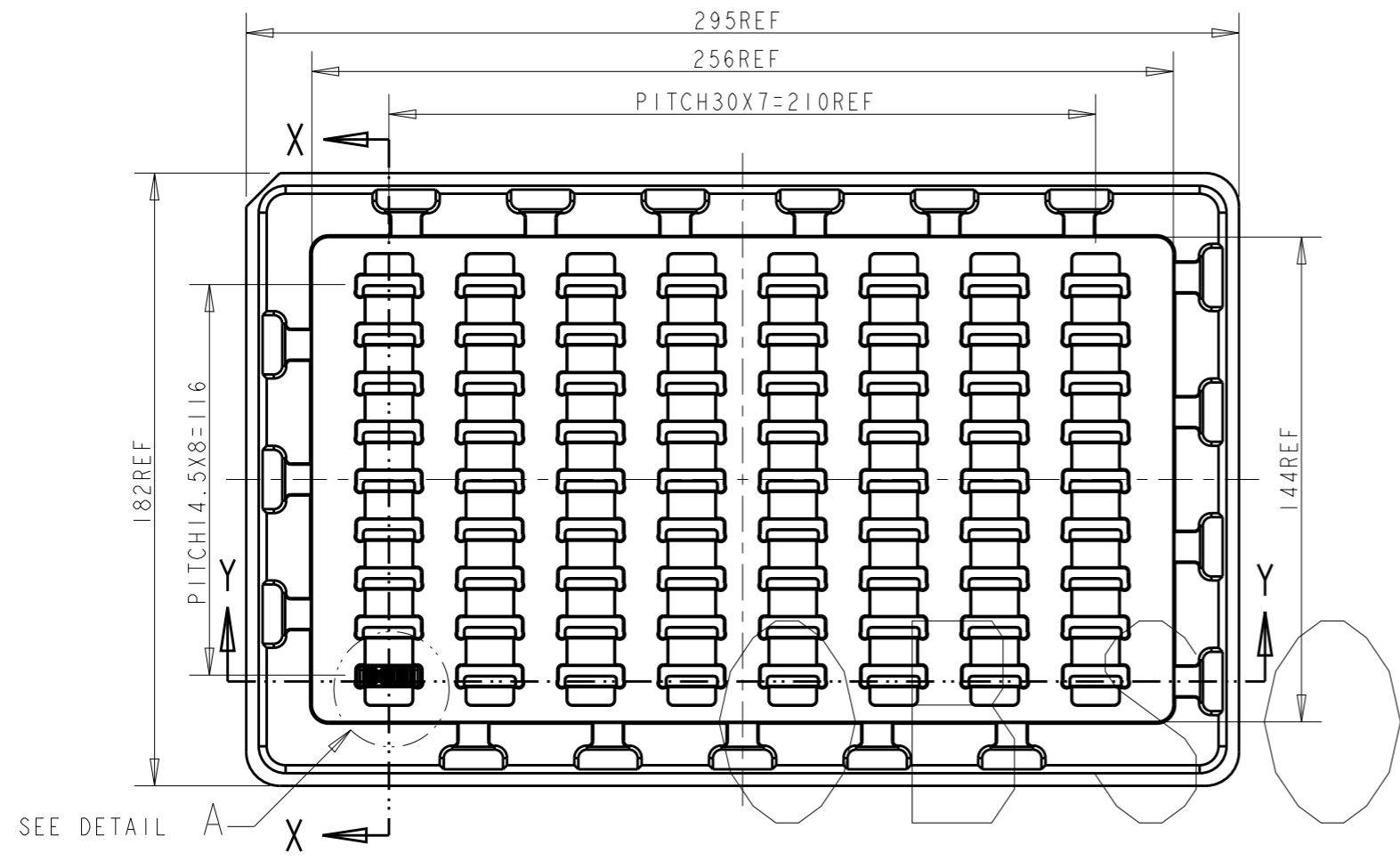

AS SHOWN: 1932008-1/1-1932008-1
72PCS/TRAY

THIS PRINT IS
PRELIMINARY
 UNQUALIFIED PRODUCT
 CONTACT PRODUCT ENGINEERING
 BEFORE USING THIS PRINT

THIS DRAWING IS A CONTROLLED DOCUMENT FOR TYCO ELECTRONICS CORPORATION
 IT IS SUBJECT TO CHANGE AND THE CONTROLLING ENGINEERING ORGANIZATION
 SHOULD BE CONTACTED FOR THE LATEST REVISION.

DIMENSIONS: mm	TOLERANCES UNLESS OTHERWISE SPECIFIED:
	0 PLC ±-
	1 PLC ±0.3
	2 PLC ±0.3
	3 PLC ±0.3
	4 PLC ±-
	ANGLES ±-
MATERIAL -	FINISH -

DWN ALEX SHOAL 29APR2007	Tyco Electronics Corporation Shanghai P.R.CHINA 200233
CHK WENKE HE 29APR2007	
APVD STEVEN YAO 29APR2007	
PRODUCT SPEC 108-78292	NAME RECEPTACLE ASSEMBLY 2.0mm PITCH 7POS. BATTERY CONNECTOR
APPLICATION SPEC -	SIZE A3
WEIGHT 0.87g	CAGE CODE 00779
CUSTOMER DRAWING	DRAWING NO. G-1932008
	RESTRICTED TO
	SCALE 7:1
	SHEET 2 OF 2
	REV B4