

MIN MOUNTING PITCH

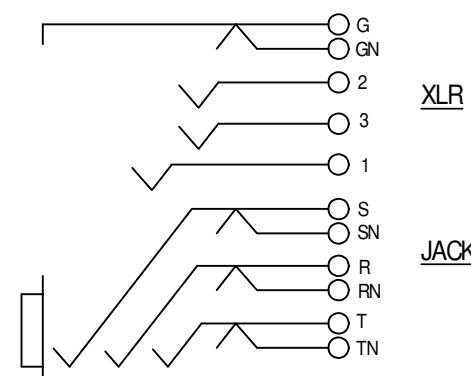

CONTACT SCHEMATIC DIAGRAM

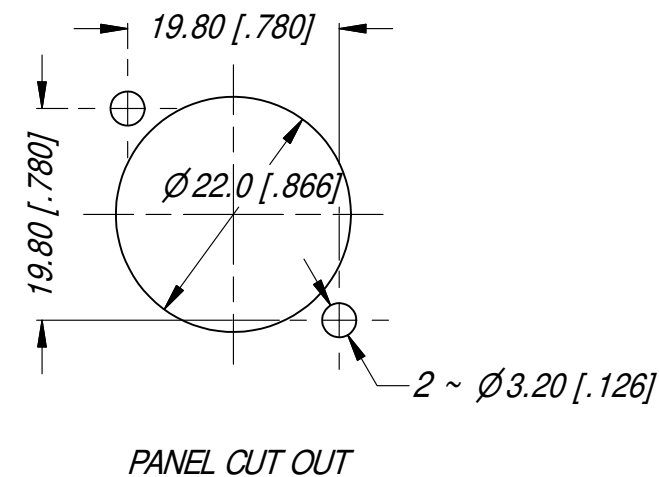

PANEL CUT OUT

PCB LAYOUT
SCALE 3:2

UNLESS OTHERWISE SPECIFIED TOLERANCE TO BE	
LINEAR	ANGULAR
X ± 0.5	X ± 1
X.X ± 0.1	X.X ± 30'
X.XX ± 0.05	X.XX ± 15'
BREAK ALL SHARP EDGES AND REMOVE ALL BURRS	
DO NOT SCALE	
DIMENSIONS IN MILLIMETRES	

THIS DOCUMENT IS THE PROPERTY OF AMPHENOL AUSTRALIA PTY. LTD.
NO PART THEREOF MAY BE REPRODUCED AND USED WITHOUT THE PRIOR WRITTEN CONSENT OF THE OWNER.

MATERIAL: SEE COMPONENTS	DRN: T.N	DATE: 27/02/12
	CKD: P.M	DATE: 27/02/12
	APPD: P.M	DATE: 27/02/12
FINISH:	SCALE: 3:2	SIZE: A4

Amphenol

Amphenol Australia Pty.Ltd,
22 Industry Blvd, Carrum Downs VIC 3201

TITLE:
**C TYPE LOW PROFILE
10 CONTACTS VERT
CUSTOMER DWG**

PART No: ACJC10AV	REV 2
DRAWING No. 55010814-000	SHEET 2 / 16