

**RIGHT ANGLE PLUG CRIMP TYPE
CABLE 2.6/50 S**

R161.181.000
SERIES N

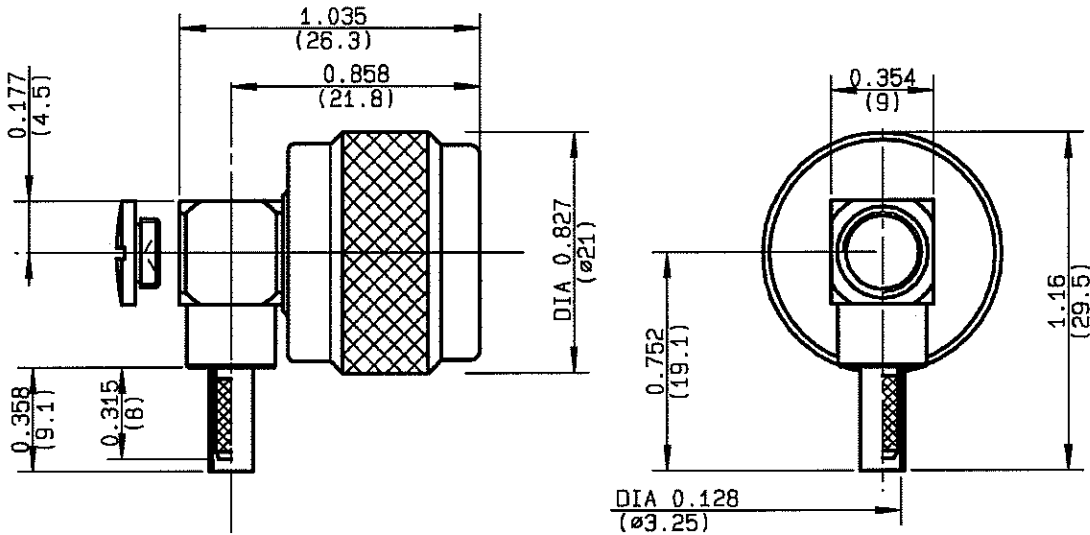

NOMINAL IMPEDANCE	50 Ω
FREQUENCY RANGE	0-11 GHz
TEMPERATURE RATING	-55/+155 °C
V.S.W.R	1.70* + x F(GHz)Maxi
RF INSERTION LOSS	0.07* √F(GHz) dB Maxi
VOLTAGE RATING	850 Veff Maxi
DIELECTRIC WITHSTANDING VOLTAGE	1500 Veff Mini
INSULATION RESISTANCE	5000 MΩMini
HERMETIC SEAL	NA Atm.cm ³ /s
LEAKAGE (pressurized only)	NA
MECHANICAL DURABILITY	500 Cycles
WEIGHT	30.67 gr
SPECIFICATION	* 0-6 GHz.

CABLES : **KX 22A**
RG 188
RG 316

OTHERS CHARACTERISTICS

CABLE RETENTION	40 N Mini
CENTER CONTACT RETENTION	
Axial force - mating end	27 N Mini
Axial force - opposite end	27 N Mini
Torque	NA cm.N Mini
RECOMMENDED TORQUES	
Mating	130 cm.N
Panel nut	NA cm.N
Clamp nut	NA cm.N

CONNECTOR PARTS	MATERIALS	FINISH	(all values are given) in micrometers
BODY	BRASS	BBR 2	
OUTER CONTACT	BRASS	BBR 2	
CENTER CONTACT	BRASS	GOLD 0.5 OVER NICKEL 2	
INSULATOR	PTFE	-	
GASKET	SILICONE RUBBER	-	
OTHERS PIECES	BRASS	BBR 2	

ISSUE
0737B

CREATION DATE
03/04/1997

FILE PART-NUMBER
EPC 96-07



QUERIN

The information given here is subject to change without notice.
Design changes may be in order to improve the product.

Connect to the future



R161.181.000

ISSUE 0737B SERIES N

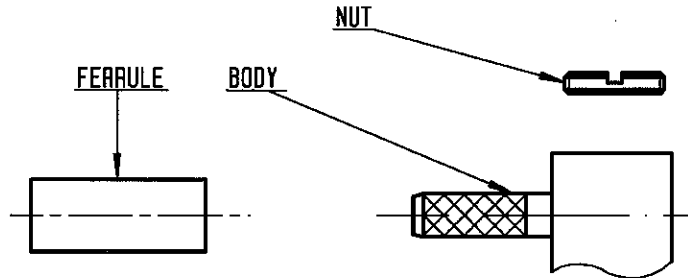

① Slide onto the cable the ferrule .
Strip the cable .
-
-

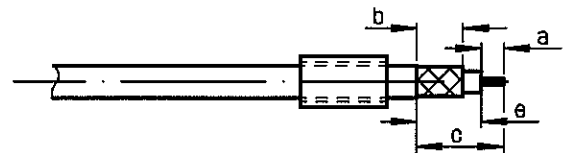

Stripping	a	b	c	d	e
inch	0.138	0.276	0.709	0	0.571
mm	3.5	7	18		14.5

② Fan the braid .
Push connector body under the braid .
Slide the ferrule on the braid
(in direction F)
-
-
-
-

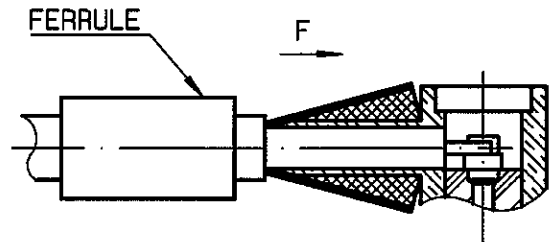

③ Crimp the ferrule with crimping tool
R282 211 000 (Hex. : .128) or
crimping tool R 282 293 000 (M22520/5-01)
+ dies R 282 235 003 (M22520/5-03)
Solder inner conductor .

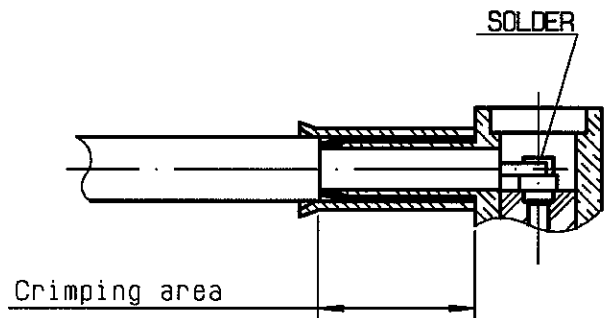

④ Screw the clamp nut into the body.
-
-

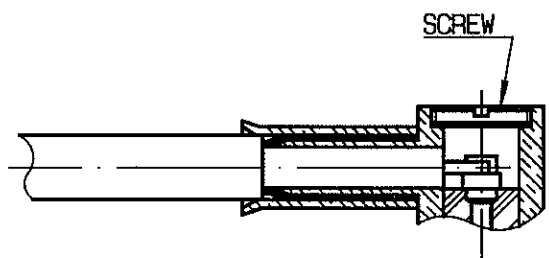

QUERIN