

## EnerChip™ CC Energy Harvester Evaluation Kit

### System Features and Overview

CBC-EVAL-10B is a demonstration kit that provides designers a platform to easily develop Energy Harvesting (EH) solutions using the EnerChip™ CBC3150 configured to operate in an energy harvesting mode. The kit combines a small solar panel, power management circuit, energy storage, regulated output voltage, and input/output pins for connection to commercially available microcontroller (MCU) and radio boards. A 16-pin CBC51100 module is included as a daughter board, providing the EH functions, battery management, and 100μAh of solid state rechargeable energy storage. CBC-EVAL-10B is a practical, low cost realization of an EH-based power system that can provide many years of service without need of battery maintenance.

- Controls charge voltage and discharge cutoff circuit for maximizing the service life of the EnerChip batteries within the CBC3150 and auxiliary CBC050 energy storage device on the CBC51100 module.
- Manages internal circuitry for switching from PV power to EnerChip (or external battery) power when ambient light level is too low to power the system and/or recharge the energy storage devices.

CBC-EVAL-10B is shown in Figure 1. The CBC-EVAL-10B kit block diagram is shown in Fig. 2.

CBC-EVAL-10B has the following elements:

- Energy harvesting circuitry that matches the impedance of photovoltaic cells to ensure maximum power transfer to system load and on-board energy storage devices
- Solid state energy storage with thousands of charge-discharge cycles available
- Integrated battery management that controls battery charging and discharge cutoff, ensuring maximum service life of on-board storage cells
- Provision for additional energy storage (primary or rechargeable batteries) with switchover control circuit to meet application requirements
- Input overvoltage protection and extra high impedance for use with smaller solar cells
- Input/output headers for connection to system components such as radios and microcontrollers
- On-board charge status LED and push-button

The photovoltaic (PV) panel included in the CBC-EVAL-10B converts ambient light energy into electrical energy, which is fed into the CBC3150 device residing on the CBC51100 module. The CBC3150 performs several important functions:

- Matches the load impedance of the PV transducer to the EnerChip impedance to ensure maximum power conversion efficiency from the PV cells to the energy storage and system load.

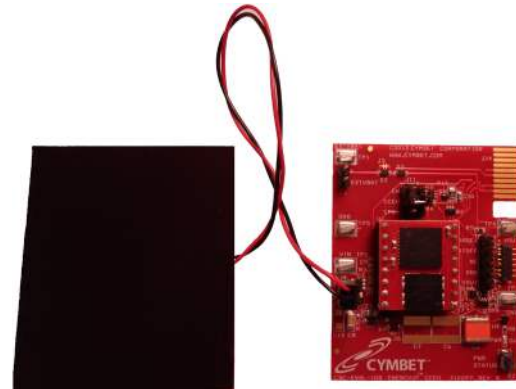

Figure 1: CBC-EVAL-10B Demo Kit.

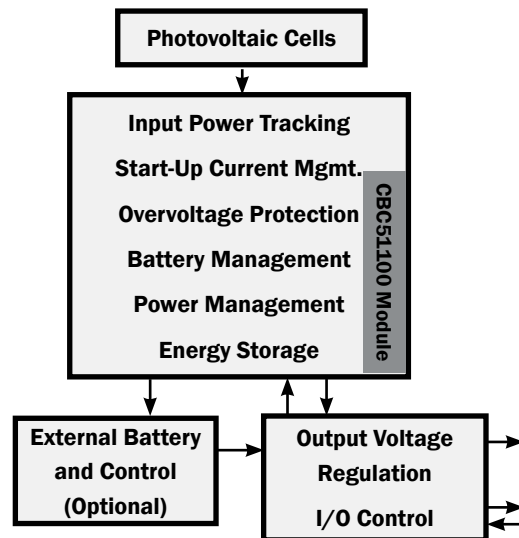

Figure 2: EnerChip CBC-EVAL-10B Demo Kit block diagram. The functions in the center block are performed by the EnerChip CBC51100 module.

# CBC-EVAL-10B EnerChip CC EH Evaluation Kit

## CBC-EVAL-10B Module Connectors, Jumpers, and Test Points

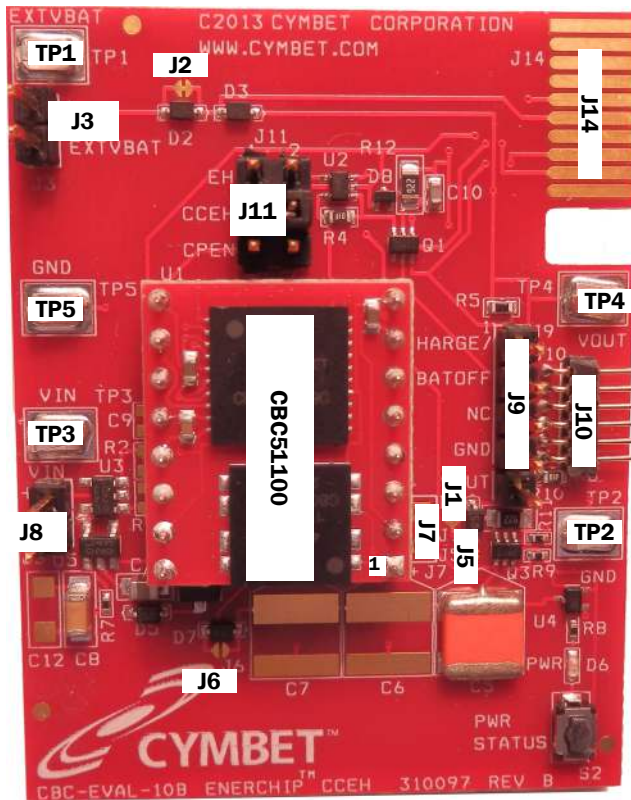

Figure 3: Locations of connectors, jumpers, and test points.

CONNECTORS		
Connector	Pin Number	Designation
J3	1	External Primary Battery Input (+)
	2	External Primary Battery Input (-)
Connector Type: Terminal Block		
J7	1	External Rechargeable Battery Input (+)
	2	External Rechargeable Battery Input (-)
Connector Type: Vias		
J8	1	PV Cell Input (+)
	2	PV Cell Input (-)
Connector Type: Terminal Block		
J9	1	CHARGE/
	2	BATOFF
	3	No Connection
	4	GND
	5	VOUT
Connector Type: Vertical SIP		
J10	1	BATOFF
	2	GND
	3	No Connection
	4	No Connection
	5	VOUT
	6	CHARGE/
Connector Type: Right Angle SIP		
TEST POINTS		
Test Point	Designation	
TP1	External Primary Battery (+)	
TP2	GND	
TP3	DC Input (PV+)	
TP4	VOUT	
TP5	GND	

JUMPERS		
Jumper	Pin Number	Designation
J1	1-2	External Battery to LDO Enable
J2	1-2	External Battery Mode Enable
J5	1-2	VOUT to LDO Enable
J6	1-2	Voltage Threshold Detect to LDO Enable
J11	1-2	External Control of Energy Harvesting
	3-4	Normal Energy Harvesting Mode
	5-6	Disable Energy Harvesting

# CBC-EVAL-10B EnerChip CC EH Evaluation Kit

---

## CBC-EVAL-10B Module Connector Descriptions

**J3:** Terminal block for connecting the positive and negative terminals of an external non-rechargeable primary battery. See specifications elsewhere in this document for the minimum and maximum allowable battery voltage before attaching a battery to this connector.

**J7:** Header pins to be used only for the purpose of connecting the positive and negative terminals of an external 4.1V rechargeable battery. No other connections are allowed on these pins and the pins are not to be shorted together. See specifications elsewhere in this document for the minimum and maximum allowable external battery voltage before attaching a battery to this connector.

**J8:** Terminal block for connecting a photovoltaic cell (or other DC voltage). See specifications elsewhere in this document for the minimum and maximum allowable DC voltage to be applied to this connector.

**J9 and J10:** Power and handshaking signals for connection to a target board - e.g. wireless end-point module. (For reference, header connector J9 is a 5-pin section of Samtec 50-pin header p/n TSW-150-07-G-S. Header connector J10 is Mill-Max p/n 850-10-006-20-001000; the socket it mates to is Mill-Max p/n 851-93-006-20-001000.)

**J14:** Used for factory test purposes only. Do not make any connections to J14.

**Cable Assembly** - A 5-conductor cable with a header connector at each end is provided with CBC-EVAL-10B to facilitate connection between the J9 connector and a 5-pin header on the user's board.

## Getting Started

To operate the CBC-EVAL-10B in the standard energy harvesting mode, using the EnerChips as the storage devices, leave each of the several jumpers in the same position as received. The factory default settings are as follows:

<u>Header</u>	<u>Shorting Jumper, Connector, or Solder Trace/Pad</u>
J3	Optional external primary battery.
J7	Optional external rechargeable battery. DO NOT APPLY A SHORTING JUMPER TO J7 UNDER ANY CIRCUMSTANCES! Doing so will destroy the EnerChips.
J8	PV Cell Input (2.5VDC to 5.5VDC)
J9	System I/O (See J9 and J10 Pin Descriptions Table)
J10	System I/O (See J9 and J10 Pin Descriptions Table)
J11	Pin 3 to Pin 4
J14	No Connections Necessary (Used for Factory Testing)

# CBC-EVAL-10B EnerChip CC EH Evaluation Kit

After confirming the header pins are properly configured, simply connect the 2-wire cable assembly from the PV panel to jumper J8. [Note polarity; red wire goes to the positive terminal, pin 1.]

Expose the PV panel to ambient light of greater than 200 Lux. The EnerChip storage devices on the CBC51100 module will begin to charge and power will be supplied to the load via header pins J9 and J10. The magnitude of power available to the load will be a function of the ambient light, the angle of incidence of light to the PV panel, and the state of charge of the EnerChips.

To verify that the circuit is operating properly, measure the voltage on any of the readily accessible test points:

<u>Test Point</u>	<u>Node Description</u>
TP1	External Battery Terminals
TP2	System Ground
TP3	PV Input
TP4	Switched Output
TP5	System Ground

The various header pins may also be used as test measurement points. Refer to the schematic of Figure 6.

Reference the CBC3150 data sheet for operating characteristics of the CBC3150.

Users may populate R2 and R3 to set the maximum power point of the DC transducer. See the CBC3150 data sheet for recommended resistor values. Note that the resistor divider will present a parasitic load to the transducer. Changing these resistors will also require a different voltage POR circuit U3 if you are moving the voltage down from 3.0 volts.

## Connecting CBC-EVAL-10B to the System

The CBC-EVAL-10B board has two control lines that can be connected to a microcontroller (MCU) for the purpose of conserving available energy, using incoming power efficiently, and extending EnerChip battery life. The table below describes the functionality of the J9 and J10 connector pins.

<b>J9 and J10 Pin Descriptions</b>	
<b>Pin</b>	<b>Designation</b>
<b>BATOFF</b>	<b>Input control line to the CBC-EVAL-10B for disconnecting the EnerChips from the CBC-EVAL-10B charging circuit. See the section System Design Recommendations to Save Power for additional information.</b>
<b>CHARGE/</b>	<b>Active low output from the CBC-EVAL-10B indicating that the EnerChips have been charged or are being charged (provided CBC3150 EN pin was/is high). CHARGE/ is an open drain output with an internal 1.0M<math>\Omega</math> pull-up resistor to VOUT. See the section System Design Recommendations to Save Power for additional information.</b>
<b>VOUT</b>	<b>CBC-EVAL-10B output power</b>
<b>GND</b>	<b>System ground</b>
<b>NC</b>	<b>No connection (J9 has one NC pin and J10 has two NC pins)</b>

# CBC-EVAL-10B EnerChip CC EH Evaluation Kit

---

- BATOFF is typically controlled by a microcontroller I/O line. When driven high, the CBC3150 charge pump will be disabled. This feature allows all available power to be delivered to the load rather than to charging the EnerChips, a useful mode when limited transducer power is available or when higher operating current is required from the system. When BATOFF is driven low, the interaction between the charging source and the CBC-EVAL-10B behaves normally. In other words, when BATOFF is low the EnerChips will always be charging when sufficient input power is available.
- CHARGE/ is an output signal from the CBC-EVAL-10B. CHARGE/ is a filtered logical inversion of the CBC3150 RESET/ output signal. Therefore, CHARGE/ will be driven low (RESET/ driven high) whenever VIN is at a voltage above the VMODE switchover setpoint (nominally 3.0V with VMODE tied to GND). In CCEH mode - as configured by jumper J11 - RESET/ is tied to EN, meaning the charge pump will be active and the batteries will be charging only when RESET/ is high. During operating conditions when RESET/ is toggling on and off at some duty cycle (for example in low light), CHARGE/ will not toggle but send a filtered version that does not toggle. To determine whether the batteries are charged during such conditions, an MCU could be programmed to interrogate the CHARGE/ to determine whether the batteries are charged and available for use.
- VOUT is the DC output voltage from the CBC-EVAL-10B and is typically 3.2V depending on system configuration and load current. It provides power to the system according to the Operating Characteristics table shown below.
- GND is the ground connection of the CBC-EVAL-10B. It is to be connected to the system ground line.

## CCEH Energy Harvesting

The energy harvesting technique used in the CBC-EVAL-10B is referred to as CCEH for Charge Controller Energy Harvesting. This technique uses the ASIC inside the CBC-3150 part to harvest energy from a transducer such as a solar cell at its Maximum Peak Power Point (MPPT). The most basic circuit implementing CCEH has a capacitor on the input of the CBC-3150 to charge up from the solar cell to a voltage where the RESET/ line on the CBC-3150 part transitions high meaning that the input voltage is higher than the VMODE comparator threshold. Since RESET/ is wired to the charger EN pin, when RESET/ goes high it starts the charger which moves charge from the input capacitor to the EnerChip at a higher voltage to charge the EnerChip. The movement of charge out of the input capacitor draws the input voltage down since it is assumed that the solar cell is relatively high in impedance and cannot supply enough current to power the charger. This action causes the RESET/ line to drop which turns off the charger and allows the input capacitor to again charge up from the input transducer. In this manner the input capacitor is held to nearly the VMODE threshold and the transducer delivers its current into essentially a fixed voltage which must be selected to be the MPPT voltage of the transducer for maximum efficiency.

The CBC-EVAL-10B uses the basic CCEH harvesting technique but also implements some optional circuitry to improve its performance in startup and to add some useful features. The following sections describe the input and output circuit additions.

# CBC-EVAL-10B EnerChip CC EH Evaluation Kit

---

## Operating Modes

CBC-EVAL-10B can be configured to operate in any of three modes, as required by the application. The operating mode is set by configuring the various jumpers on the CBC-EVAL-10B. [See Figure 3 and the associated tables for jumper settings associated with each of the operating modes.] The three operating modes are as follows:

Standard energy harvesting mode using PV cells, on-board EnerChips, clamped output voltage, and switchover control circuit to ensure a seamless transition from PV power to EnerChips when little or no ambient light is available. In this mode, power from the PV cells is used to power the system load and charge the EnerChips when sufficient light is available. With very low or no ambient light, the system operates from on-board EnerChips. Variations of this mode are configured using jumper select pins J11, allowing the user to drive the internal charge pump of the CBC3150 through one of three control methods, as indicated on the silk screen next to J11:

- a) EH: External control using the BATOFF control line. Used when an external microcontroller derives input from CHARGE/ in an 'energy-aware' operating mode.
- b) CCEH: CBC3150 RESET/ output is fed to CBC3150 ENABLE input in a standard transducer impedance matching mode.
- c) CPEH: VIN controls the CBC3150 ENABLE line. When the input transducer voltage falls below 2.5V, the CBC3150 charge pump is disabled.

## “Battery Assist” Hybrid Energy Harvesting/Battery Configurations

The Primary Hybrid EH configuration relies on not only the on-board EnerChips for energy storage, but also taps into the capacity of a conventional non-rechargeable battery when the EnerChips are at low state-of-charge (such as during extended periods of darkness). Typical primary batteries might be 2-series alkaline cells, coin cells, or certain cylindrical cells having output voltage of 3V to 3.6V. This 'battery assist' energy harvesting mode can be used to supplement conventional batteries, extending their operational life by months or years.

Rechargeable Hybrid EH configuration uses not only the PV cells and on-board EnerChips, but also an external rechargeable battery such as a rechargeable coin cell or other small, Li-ion or Li-polymer cells having a charging voltage of ~4.1V. This 'extra capacity' operating mode allows the designer to incorporate a higher capacity rechargeable battery in order to achieve longer system run-time in periods of darkness than what the EnerChips can provide, while avoiding the relative bulk associated with non-rechargeable cells.

In all operating modes, the input power source - whether PV cells, EnerChips, or external battery - passes through an integrated voltage dropping diode that supplies power to VOUT at 0.5V lower than the EnerChip voltage of 3.7-3.9V. The output voltage is then typically 3.2 to 3.4V with light loading. The output voltage is switched on by power-on-reset (POR) circuit when the current-pulse capacitors reach 2.9 volts the first time since they were discharged. To avoid starving the external system elements of power particularly during start-up or when pulse currents are required by the system, the POR circuit enables the output only after the output capacitors are fully charged to a voltage above the 2.9V voltage. Consequently, the user must recognize the relationship between the POR trip voltage and the output turn-on voltage when designing with a POR/LDO combination other than the components installed on the CBC-EVAL-10 module.

## EH Status LED and Push Button Switch

The Eval-10B also includes a switch and LED combination that is connected to the output POR circuit and indicates whenever the output capacitors are above 2.9V. When the switch is pressed the LED turns on and draws the output capacitors down to 2.9V where the LED turns off until the POR detects the output capacitor voltage rising above 2.9V when the LED turns on again and the cycle repeats. This allows qualitative indication of the available power by the speed the LED blinks.

# CBC-EVAL-10B EnerChip CC EH Evaluation Kit

---

## External Control of the CBC-EVAL-10B Energy Harvesting Functions

In addition to protecting the EnerChips from being discharged too deeply in low ambient light conditions or abnormally high current load conditions, the CBC3150 power management circuit also ensures that the system load is powered with a smooth power-on transition. The power management circuit has a control line (CHARGE/) for indication to the system controller that the energy harvester is charging the EnerChips. A control line input (BATOFF) is available for the external controller to disable the CBC3150 charge pump. Use of these two control lines is optional.

There are two connectors on CBC-EVAL-10B for connection to target devices to be powered. Either the J9 or J10 connector can be used for low power microcontroller-based systems. In the case of a low power wireless end device, the CBC-EVAL-10B has storage energy for approximately 1000 radio transmissions - depending on protocol used - in no/low ambient light conditions.

Microcontroller-based systems that are powered by the CBC-EVAL-10B should contain firmware that is “Energy Harvesting Aware” and take advantage of the power management status and control signals available on CBC-EVAL-10B.

## Using Additional EnerChips and External Batteries

The CBC-EVAL-10B is designed to permit attachment of rechargeable or non-rechargeable batteries whereby the energy harvesting circuitry extends the life of those batteries by operating from (i) PV cell power when sufficient light is available, (ii) EnerChips when in an acceptable state-of-charge, and (iii) the external battery when neither of those two conditions exists.

Two classes of external batteries may be attached to the CBC-EVAL-10B:

1. A primary battery (i.e., non-rechargeable) or series combination of primary batteries may be connected to header pins J3 only. The acceptable voltage range is 2.7 to 3.6. Commonly used batteries in this category are:

a single 3V CR-type or BR-type coin cell (e.g., CR2032, BR2032), or two alkaline cells (e.g., AAA, AA, C, D) connected in series;

a single 3.6V thionyl chloride cell may also be used.

[Contact Cymbet for recommendations in selecting a primary battery for your Hybrid configuration.]

2. A secondary (i.e., rechargeable) battery may be connected to header pins J7 only. The acceptable charging voltage range is 4.0V to 4.2V. The charging source for this battery is the VCHG output pin of the CBC3150 that normally charges the EnerChips to 4.1V. Maximum drive current of this pin is on the order of 1mA. VCHG drive current can be adjusted by populating charge pump capacitor C9 (CBC-EVAL-10B module is shipped without a capacitor C9 but the CBC51100 module has a default capacitor). See DS-72-03 EnerChip CC CBC3150 Data Sheet for guidelines on sizing the charge pump capacitor. The discharge cutoff voltage is fixed at 3.0V +/- 0.3V. Examples of rechargeable batteries supported by CBC-EVAL-10B are the LiR-type coin cells, including LiR-1220 (~8mAh) and LiR-2032 (~40mAh). The charging rate for these external cells will be a function of available light, to a maximum of 1mA as limited by the CBC3150 charge pump drive current.

To operate the CBC-EVAL-10B board for use with an external battery, configure the header pins as follows:

- Non-rechargeable (i.e., primary) battery connected to EXT BAT terminal block J3. Connect battery to J3, ensuring polarity is correct.
- Rechargeable (i.e., secondary) battery connected to header pins J7. Connect battery to J7, ensuring polarity is correct.

# CBC-EVAL-10B EnerChip CC EH Evaluation Kit

## EVAL-10B CCEH Operation During EnerChip Battery Charging

The following scope traces show the operation of the EnerChip CBC3150 operation under two different light conditions. The scope trace in Figure 4 was taken under a light source of 500 Lux on the EVAL-10B solar cell. The Input voltage trace on the top line in Yellow shows the activity at Test Point TP3. The input voltage is at 3.6 Volts until the EnerChip Charging Circuit activates as shown on the second trace which is the activity on the RESET/ pin on the CBC3150. The EVAL-10B 3.3V output voltage during these activities is shown in the green trace.

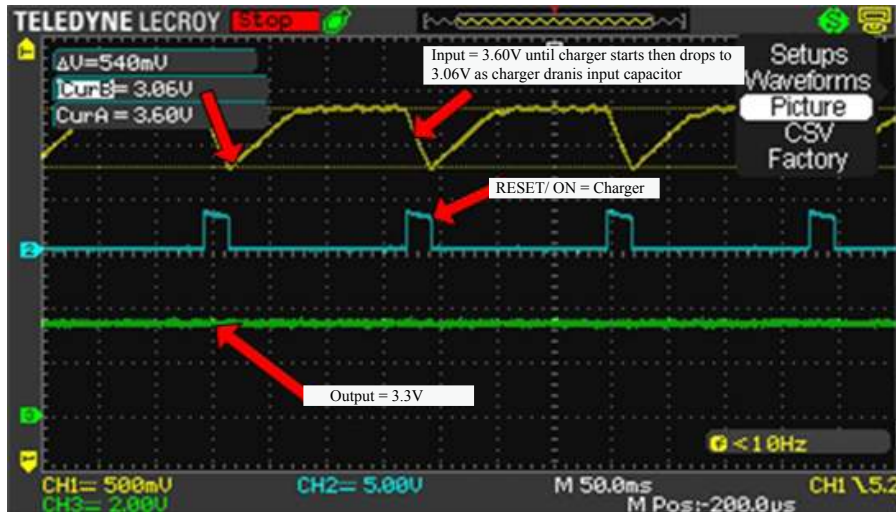

Figure 4 : EVAL-10B operation at 500 Lux light intensity

The scope trace in Figure 5 was taken under a light source of 100 Lux on the EVAL-10B solar cell. The Input voltage trace on the top line in Yellow shows the activity at Test Point TP3. Given the decrease in light level, the input voltage is at 3.25 Volts until the EnerChip Charging Circuit activates as shown on the second trace which is the activity on the RESET/ pin on the CBC3150 which has a shorter pulse width in low light conditions. The EVAL-10B 3.3V output voltage is still preserved in this case as shown in the green trace.

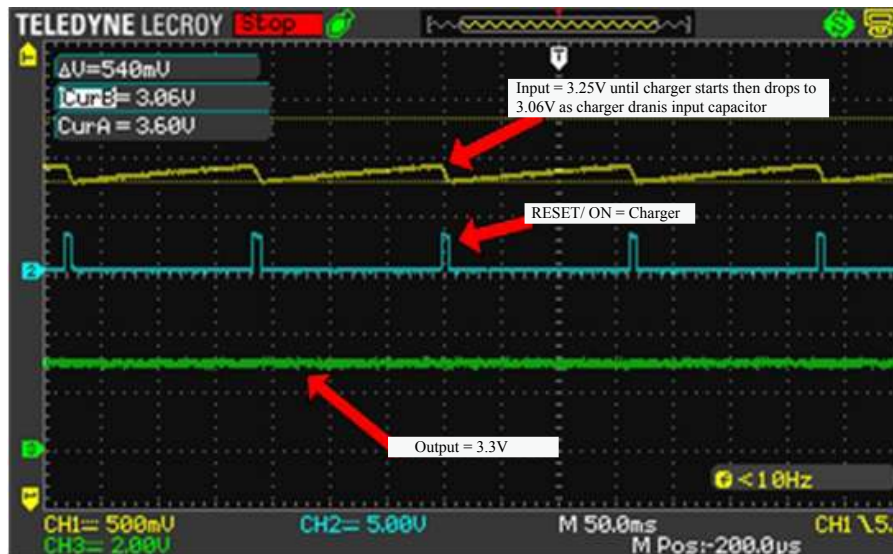

Figure 5 : EVAL-10B operation at 100 Lux light intensity



# CBC-EVAL-10B EnerChip CC EH Evaluation Kit

---

## Input Circuit Description

The input circuit of the CBC-EVAL-10B consists of input capacitor C8 (C12), Power On Reset (POR) circuit U3 and U5, Diodes D5 and D13, capacitor C11 and resistor R7. The input circuit is designed to allow the CBC-EVAL-10B to smoothly start up with small solar cells in very low lighting conditions while protecting the CBC-EVAL-10B circuitry as well as the user load circuitry from overvoltage conditions caused by larger solar cells in direct sunlight. The circuit consists of two sections: the input impedance buffer and the overvoltage clamp.

The input impedance buffer is mainly U3 which has a very low input leakage current and, when paired with the input capacitor C8 (C12 optional) provides a very light load to the solar cell on startup. The CBC3150 on the CBC5100 module can normally be used without this input buffer with large solar cells or use-cases that assure solar cell output current of over 70 $\mu$ A during startup. The CBC3150 ASIC, like most other ICs, can demand many times more than its rated 3 $\mu$ A quiescent current as it reaches its internal startup voltage, typically below 2 volts. POR circuit U3 presents a load of under 1 $\mu$ A to the solar cell provided C8 is large enough to prevent oscillation. When U3 reaches its switching voltage of 2.7 volts it raises its VOUT pin which then powers the rest of the CBC-EVAL-10B circuitry with as much current as it needs to break through the startup current surge. After the CBC3150 ASIC has been started, it only draws its rated quiescent current during the rest of the operation.

The overvoltage clamp consists of U5, D13, D5, C11, and R7. The diodes are used to make U5 switch at a higher voltage simply to avoid using two different voltage POR circuits on the input circuit. The diode arrangement makes the clamp go off at input voltages above 3.3V. When VOUT of U5 switches high, it shunts current from the solar cell and the input capacitor C8 (C12) to ground until the input voltage drops below 3.3 Volts. The CBC3150 ASIC turns on its charge pump at 3.0 volts with the default setup of R2 and R3. When the charge pump turns on the current from the input capacitor is boosted and sent to the EnerChips for charging. Normal operation will show the input voltage to vary between 2.9 and 3.0 volts which presents a 3.0V operating point for the input solar cell. The solar cell should be selected to have a peak power point at near 3.0V for maximum efficiency.

## Output Circuit Description

The output circuit of the CBC-EVAL-10B consists of pulse current output capacitor C5 (C7, C8 optional), Power On Reset (POR) circuit U4, diodes D4 and D6, transistor Q3, switch S2, and resistors R9, 10, and 11. The output circuit is designed to allow the pulse current output capacitors to charge up to a minimum output voltage without the load drawing down the solar cell or EnerChips before switching the output on which presents a very low impedance power source to the user load to break through any startup current requirements. Without this circuit, a user load could get stuck drawing so much current from the relatively high impedance solar cell and EnerChips that it could never break through the voltage level needed to escape the initial startup current pulse. The circuit operates by monitoring the pulse current output capacitors until they reach a sufficient voltage determined by U4 where the RESET line of U4 turns on the output transistor Q3B which switches the output on and Q3A latches the output on. Once the output is on, the RESET output of U4 lowers when the capacitors are above the threshold voltage and rises when not which, if switch S2 is depressed, will modulate LED D6 for a visual indication of the output state. The speed that D6 blinks is a measure of how fast the output capacitor is recharging, which is proportional to the amount of energy coming from the EnerChips and solar cell.

Careful selection of the message protocol for the RF link can have a significant impact on the overall power budget. In many cases, using higher power analog circuits that can be turned on, settle quickly, and immediately turned off can decrease the overall energy consumed. Microcontroller clock frequency can also have a significant impact on the power budget.

# CBC-EVAL-10B EnerChip CC EH Evaluation Kit

## Operating Characteristics <sup>(1)</sup>

Parameter	Condition	Min	Typical	Max	Units	
Input Luminous Intensity (using PV cell provided with kit)	Minimum operating Lux	150 <sup>(2)</sup>	-	-	Lux	
	Full charge rate	800 <sup>(2)</sup>	-	-	Lux	
Photovoltaic Input Voltage (VIN)	25 °C	3.1	3.2 <sup>(3)</sup>	5.5	Volts DC	
Maximum Input Transducer Resistance	Rated input voltage (VIN)	-	-	250	kohms	
External Battery Voltage	Non-rechargeable	2.7	3.0	3.6	Volts DC	
	Rechargeable	4.0	4.1	4.2	Volts DC	
Continuous Output Power (measured at VOUT pin; 25 °C)	1000 Lux (FL); battery not charging; continuous output	-	300	-	μA	
	200 Lux (FL), battery not charging	-	10	-	μA	
	No ambient light, EnerChips charged	-	2000 <sup>(4)</sup>	-	μA	
VOUT	Battery charged; 2μA load	3.0	3.2	3.5	V	
EnerChip and External Rechargeable Battery Discharge Cutoff Voltage	4.7kΩ load	3.0	3.3	3.6	V	
Pulse Discharge Current	25 °C ; 20 msec pulse	-	30 <sup>(5)</sup>	-	mA	
EnerChip Self-Discharge (non-recoverable)	5-year average 25 °C	-	2.5	-	% per year	
Operating Temperature	-	0	25	70	°C	
EnerChip Recharge Cycles (to 80% of rated capacity; 4.1 V charge voltage)	25 °C	10% depth-of-discharge	5000	-	-	-
		50% depth-of-discharge	1000	-	-	-
	40 °C	10% depth-of-discharge	2500	-	-	-
		50% depth-of-discharge	500	-	-	-
EnerChip Recharge Time (to 80% of rated capacity)	From 50% state-of-charge	-	10	-	minutes	
	From deep discharge	-	50	-	minutes	
Charging Efficiency	Vin=3.0V	-	65	-	%	
EnerChip Storage Capacity	200 μA discharge; 25 °C	100	-	-	μAh	

(1) See DS-72-03 EnerChip CC CBC3150 Data Sheet and DS-72-01 EnerChip CBC050 Data Sheet for complete specifications of the Cymbet components on the CBC51100 module included with CBC-EVAL-10B.

(2) Fluorescent (FL) light conditions. EnerChip state-of-charge >90%.

(3) Dependent on battery state-of-charge and load conditions. State-of-charge will affect average VIN. At 0% battery state-of-charge, 2.6V < VIN < 3.1V, depending on load. At 100% battery state-of-charge, VIN will approach 5.2V at 700Lux.

(4) Continuous current for up to 1 minute with CBC51100 EnerChip module.

(5) For guidelines on adjusting the pulse current capability, see AN-1025: Using the EnerChip in Pulse Current Applications.

**Specifications subject to change without notice.**

## CBC-EVAL-10B Circuit Schematics

As a result of designing the CBC-EVAL-10B to be versatile and useful for designing to any number of operating environments and system requirements, there are many circuit elements that will not be necessary for any given CCEH implementation. The full schematic of Figure 6 depicts the CBC-EVAL-10B in its entirety. A simpler and more often used embodiment is shown in Figure 7. In Figure 7, the provision for external batteries has been removed, as has the circuitry required for external system control of the CBC3150 charge pump. The schematic of Figure 7 is reduced to the essential elements necessary for implementing an energy harvesting-based design using the CBC3150 circuitry and EnerChip batteries.

# CBC-EVAL-10B EnerChip CC EH Evaluation Kit

## CBC-EVAL-10B Circuit Schematic

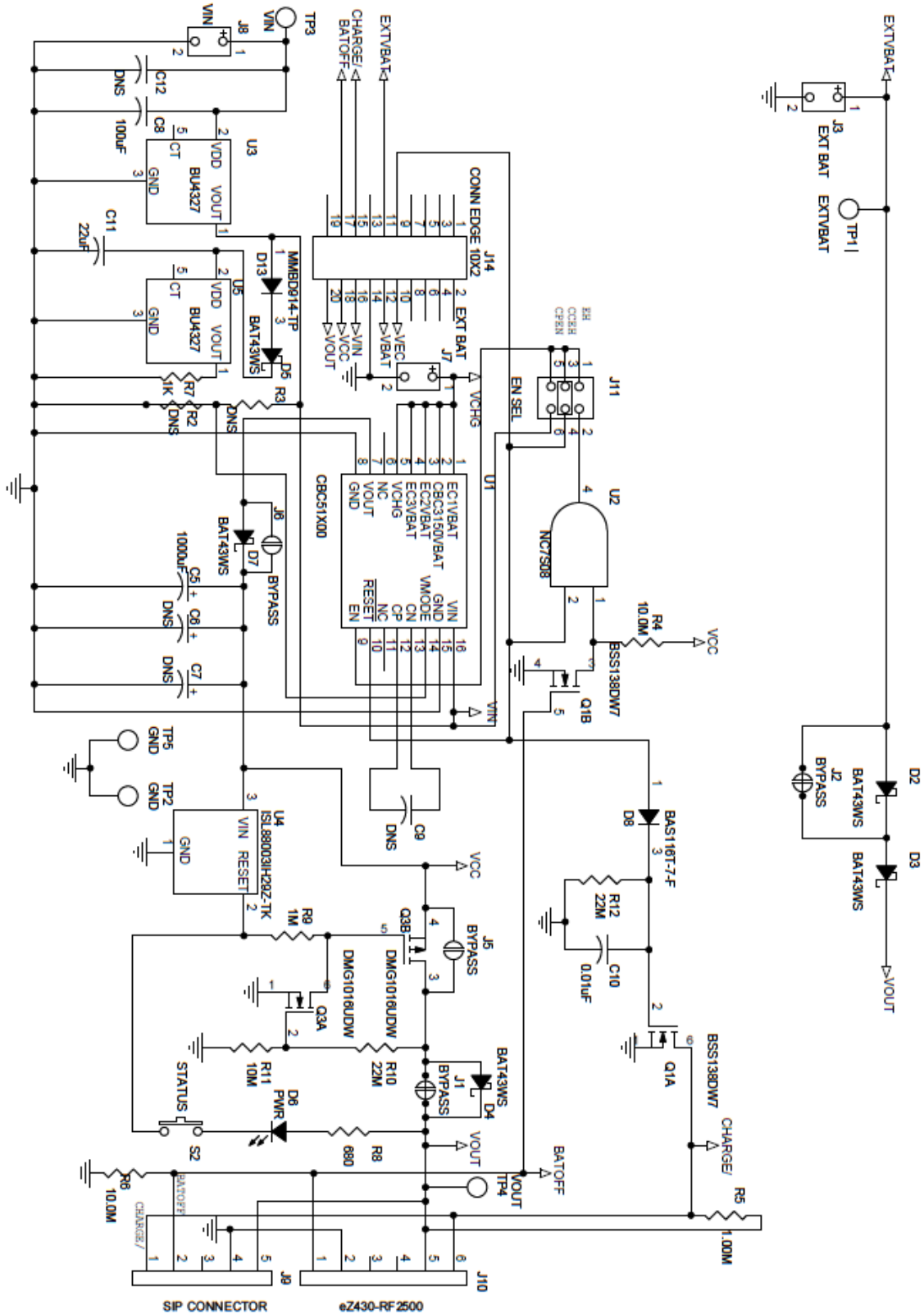

Figure 6: CBC-EVAL-10B Circuit Schematic.

# CBC-EVAL-10B EnerChip CC EH Evaluation Kit

## CBC-EVAL-10B Circuit Schematic - Simplified

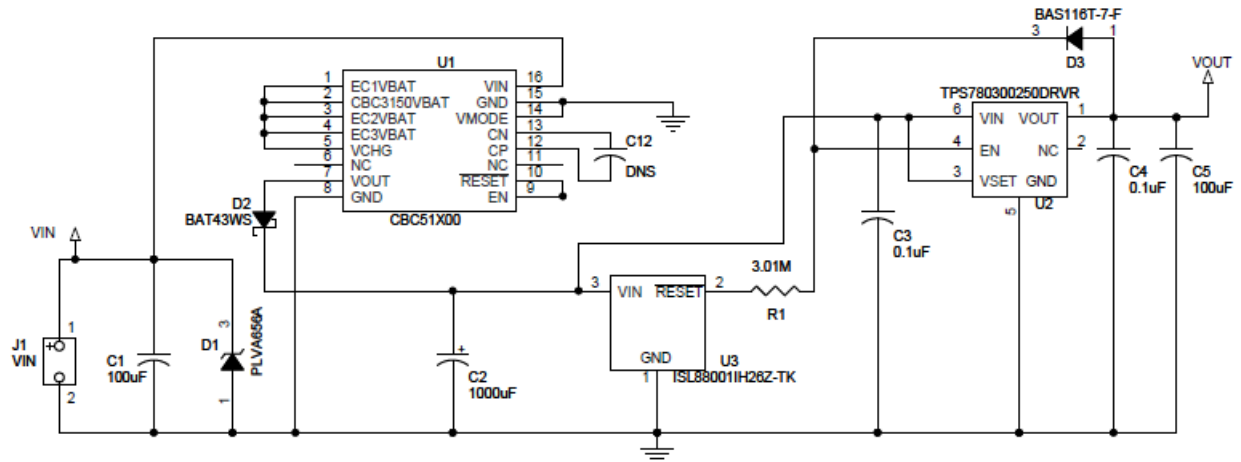

Figure 7: CBC-EVAL-10B Circuit Schematic with External Battery and External System Control Circuits Removed.

## CBC-EVAL-10B Assembly Diagrams

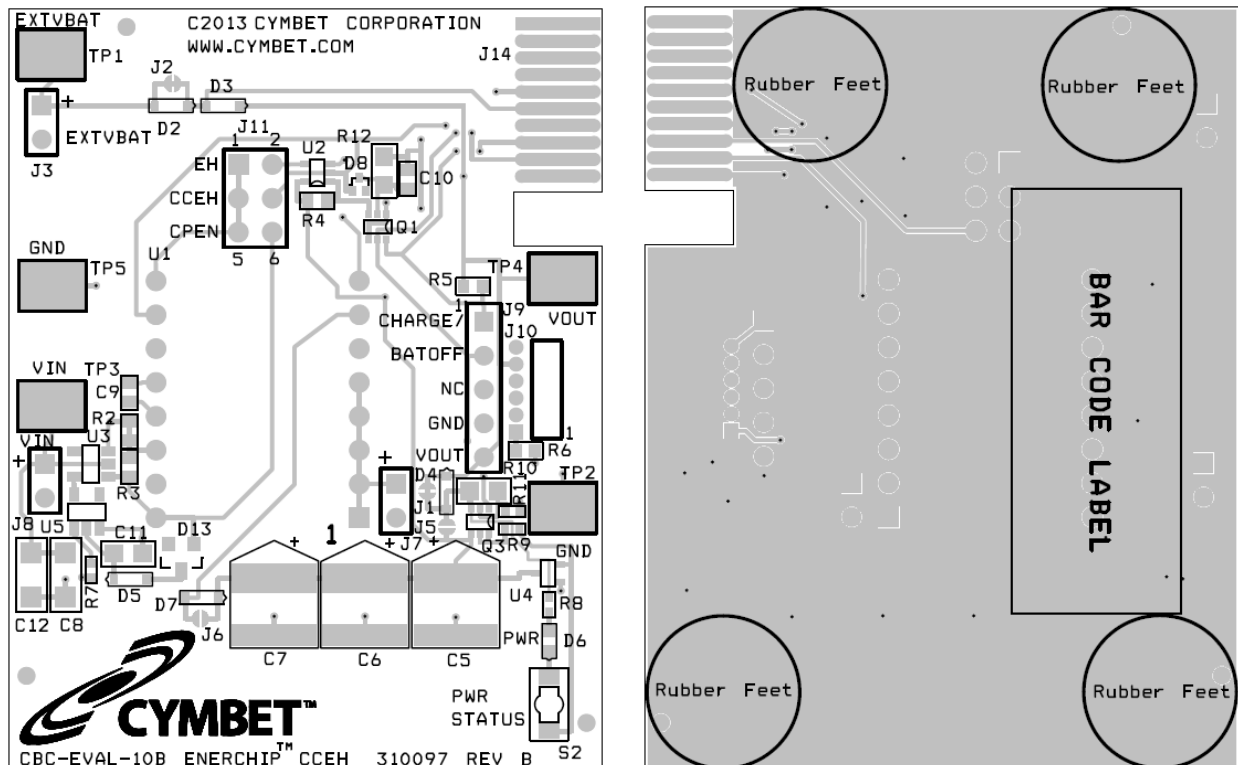

Figure 8: CBC-EVAL-10B Assembly Diagram: Top View (left); Bottom View (right).

# CBC-EVAL-10B EnerChip CC EH Evaluation Kit

## CBC-EVAL-10B Bill of Materials

Quantity	Ref Des	Manufacturer	Manufacturer Part #	Description	Distributor	Distributor Part #
1	R11	Yageo	RC0402FR-0710ML	RES 10M OHM 1/16W 1% 0402 SMD	DIGIKEY	311-10.0M/RCT-ND
2	R4 R6	Yageo	RC0603FR-0710ML	RES 10.0M OHM 1/10W 1% 0603 SMD	DIGIKEY	311-10.0M/RCT-ND
1	R9	Yageo	RC0402FR-071ML	RES 1.00M OHM 1/16W 1% 0402 SMD	DIGIKEY	311-1.00M/RCT-ND
1	R5	Stackpole Electronics Inc	RMCF0603FT1M00	RES 1.00M OHM 1/10W 1% 0603 SMD	DIGIKEY	RMCF0603FT1M00CT-ND
1	R8	Yageo	RC0402JR-07680RL	RES 680 OHM 1/16W 5% 0402 SMD	DIGIKEY	311-680J/RCT-ND
2	R10 R12	Stackpole Electronics Inc	RMCF0805JT22M0	RES 22M OHM 1/8W 5% 0805 SMD	DIGIKEY	RMCF0805JT22M0CT-ND
1	C8	Murata Electronics North Am	GRM31CF50J107ZE01L	CAP CER 100UF 6.3V Y5V 1206	DIGIKEY	490-4512-1-ND
1	C11	TDK Corporation	C2012X5R1A226M125AB	CAP CER 22UF 10V 20% X5R 0805	DIGIKEY	445-2885-1-ND
1	C10	TDK Corporation	C1608X7R1H103K080AA	CAP CER 10000PF 50V 10% X7R 0603	DIGIKEY	445-1311-1-ND
1	C5	Vishay/Sprague	592D108X96R3R2T20H	CAP 1ANT 1000UF 6.3V 10% SMD	DIGIKEY	718-1406-1-ND
5	D2 D3 D4 D5 D7	Micro Commercial Co	BAT43WS-TP	DIODE SCHOTTKY 30V 200MA SOD323	DIGIKEY	BAT43WS/STEMSCT-ND
1	D8	Diodes Inc	BAS116T-7-F	DIODE SWITCH 85V 150NMW SOT523	DIGIKEY	BAS116T-FDICT-ND
1	D13	Micro Commercial Co	MMBD914-1P	DIODE SMALL SIG 75V 0.15A SOT123	DIGIKEY	MMBD914T/PMSCT-ND
1	D6	OSRAM Opto Semi Inc	LO L129K-HZL1-24-0-2-R18-Z	LED SMARTLED 606NM ORN 0603 SMD	DIGIKEY	475-2481-1-ND
1	Q1	Diodes Inc	BSS138DW-7-F	MOSFET DUAL N-CHAN 50V SOT70-6	DIGIKEY	BSS138DW-FDICT-ND
1	R7	Yageo	RC0402FR-071KL	RES 1K OHM 1/16W 5% 0402 SMD	DIGIKEY	311-1.00K/RCT-ND
1	Q3	Diodes Inc	DMG1016UDW-7	MOSFET N+P 20V 1.07A SOT363	DIGIKEY	DMG1016UDW-7DICT-ND
5	TP1, TP2, TP3, TP4, TP5	Keystone Electronics	5016	PC TEST POINT COMPACT SMT	DIGIKEY	5016KCT-ND
1	U2	Fairchild Semiconductor	NC7S08BP5X	IC GATE AND SINGLE 2 INPUT SOT70-5	DIGIKEY	NC7S08BP5XCT-ND
2	U3 U5	Rohm	BU4327G-TR	IC VOLT SUPERVISOR 2.7V 5SSOP	DIGIKEY	BU430GCT-ND
1	U4	Intersil	ISL88003IE292-T7A	IC VOLT SUPERVISOR 2.92V SOT70-3	DIGIKEY	ISL88003IE292-T7A-ND
0.12	J10	Mill-Max Manufacturing Corp	850-10-050-20-001000	CONN HEADER RT ANG 50POS .050	DIGIKEY	ED8850-ND
0.18	J3 J8 J9	Santec	TSW-150-07-G-S	CONN HEADER 50POS .100" SGL GOLD	DIGIKEY	SAM1029-50-ND
0.06	J11	Santec	TSW-150-07-G-D	CONN HDR Dual Row 50POS .100" SGL GLD	DIGIKEY	SAM1028-50-ND
1	S2	E-Switch	TL1015AF160QG	SWITCH TACT TOP ACT 160GF SMD	DIGIKEY	EG4344CT-ND
4	FEET	3M	SJ-5303	BUMPON CLEAR 7.9MM-2.2MM	DIGIKEY	SJ5302-ND
1	LABEL		400014	SERIAL NUMBER LABEL - BAR CODE	DIGIKEY	
0.25	U1	Mill-Max Manufacturing Corp	310-43-164-41-001000	STRIP SOCKET 64 PIN SOLDER TAIL	DIGIKEY	ED8284-ND
1	PCB1		310097 REV B	Printed circuit board	DIGIKEY	

**No Stuff** J7, J14, C6, C7, C9, C12, R2, R3  
 Unused C1, C2, C3, C4,  
 Unused R1

# CBC-EVAL-10B EnerChip CC EH Evaluation Kit

## Using Other Energy Harvesting Transducers

CBC-EVAL-10B includes a standard amorphous silicon solar panel (Sanyo AM1815 type) configured as 8 series-connected cells on a glass substrate. The output voltage and current vary with incident light intensity, wavelength, and load impedance.

DC sources other than the PV cell provided with the CBC-EVAL-10B may also be used as the energy harvesting power transducer. The CBC-EVAL-10B module has an overvoltage protection circuit to clamp the input voltage to less than 3.4V which protects the CBC-EVAL-10B and any loads attached to it from overvoltage conditions on the input transducer which otherwise may exceed 7 volts. The protection circuit will clamp input currents of up to 2mA so additional protection may be needed with very high power. The minimum input voltage required to activate the internal charge pump of the CBC3150 is 2.5V. At <2.5V, the EnerChips will not charge and the power management circuit will not function. It is recommended that the input power source have a maximum power operating point as close to 3.0V as possible. Operating characteristics for most transducers are typically available from the manufacturer's data sheet. An example photovoltaic cell operating curve is shown below. Output impedance, operating voltage, and peak power point can also be verified by empirical measurements. To determine the peak power point of a given PV cell, measure the load voltage and current as a variable load impedance across the transducer is swept over a broad enough range where the peak power point can be found by finding the maximum product of the measured load voltage and current.

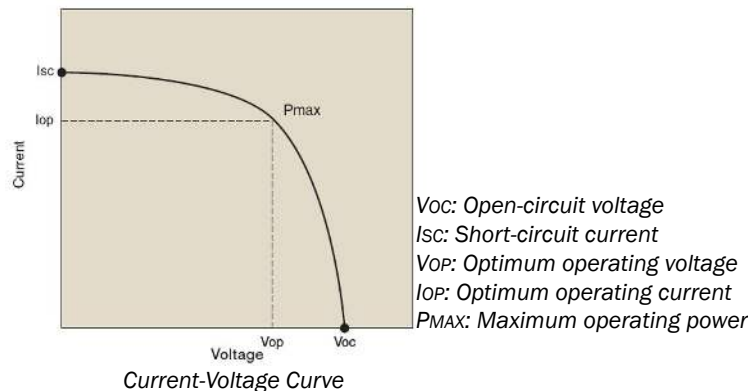

Once the peak power point of the PV cell has been determined, the CBC3150 operating point can be adjusted to match the PV cell. This is done by choosing different POR circuits with appropriate switching voltages and adding a resistor divider R2 and R3 to the CBC-EVAL-10 module. As shipped, those resistors are not populated. Cut the solder trace in the R2 location prior to adding the resistor. Resistor values should be sized according to the guidelines in the CBC3150 data sheet. It is important to note that the resistor divider will present a permanent parasitic load to the PV cells and therefore the calculation should be made to determine whether the standard CBC3150 impedance matching setpoint of ~3V - though it might not be at the peak power point of a particular PV cell - is preferred to the more optimized setpoint when considering the additional parasitic load on the PV resulting from the added resistor divider.

# CBC-EVAL-10B EnerChip CC EH Evaluation Kit

---

## System Design Recommendations to Save Power

In most system power budgets, the peak power required is not as critical as the length of time the power is required.

1. Careful selection of the message protocol for the RF link can have a significant impact on the overall power budget.
2. In many cases, using higher power analog circuits that can be turned on, settle quickly, and immediately turned off can decrease the overall energy consumed.
3. Microcontroller clock frequency can also have a significant impact on the power budget.
4. In some applications it might be advantageous to use a higher microcontroller clock frequency to reduce the time the microcontroller and peripheral circuits are active.
5. Avoid using circuits that bias microcontroller digital inputs to mid-level voltages; this can cause significant amounts of parasitic currents to flow.
6. Use 22M $\Omega$  (or larger) pull-up/down resistors where possible. However, be aware that high circuit impedances coupled with parasitic capacitance can make for a slow rise/fall time that can place the voltage on the microcontroller inputs at mid-levels, resulting in parasitic current flow. One solution to the problem is to enable the internal pull-up/down resistor of the microcontroller input to force the input to a known state, then disable the resistor when it's time to check the state of the line. If using the microcontroller's internal pull-up/down resistors on the inputs to bias push-button switches in a polled system, leave the pull-up/down resistor disabled and enable the resistor only while checking the state of the input port. Alternatively, in an interrupt-driven system, disable the pull-up/down resistor within the first few instructions in the interrupt service routine. Enable the pull-up/down resistor only after checking that the switch has been opened.
7. Microcontroller pull-up/down resistors are typically less than 100k $\Omega$  and will be a huge load on the system if left on continuously while a button is being pressed or if held for any significant length of time. For even greater reduction in power, use external pull-up/down resistors in the 10M $\Omega$  to 22M $\Omega$  range. Bias the external resistor not with the power rail but with a microcontroller port. The same algorithm used for internal pull-up/down resistors can then be used to save power.
8. The CHARGE/ line on the CBC-EVAL-10B has a 1.0M $\Omega$  pull-up resistor with a very slow rise time. Use an internal microcontroller pull-down resistor to force the CHARGE/ line low all of the time and then disable the pull-down resistor to check the state of the line. This will keep the CHARGE/ line from biasing the input at mid level for long periods of time, which could cause large parasitic currents to flow.
9. The CBC-EVAL-10B module has a feature for disabling the CBC3150 charge pump. A handshake line BATOFF is provided for use of this feature. A high level will disable the charge pump. This is useful in very low ambient energy conditions to steer all of the available energy into the load. EnerChip batteries have very low self-discharge rates (typically 2.5% per year) so it is not necessary to continuously charge them.
10. While it is relatively straightforward to calculate a power budget and design a system to work within the constraints of the power and energy available, it is easy to overlook the power required to initialize the system to a known state and to complete the radio link with the host system or peer nodes in a mesh network. The initialization phase can sometimes take two to three times the power needed for steady state operation. Ideally, the hardware should be in a low power state when the system power-on reset is in its active state. If this is not possible, the microcontroller should place the hardware in a low power state as soon as possible. After this is done, the microcontroller should be put into a sleep state long enough for the energy harvester to replenish the energy storage device. If the power budget is not exceeded during this phase, the system can continue with its initialization. Next, the main initialization of the system, radio links, analog circuits, and so forth, can begin. Care should be taken to ensure that the time the system is on during this phase does not exceed the power budget. Several sleep cycles might be needed to 'stairstep' the system up to its main operational state. The Cymbet CBC-EVAL-10B module has a handshake line CHARGE/ to indicate to the microcontroller when energy is available. Another way to know whether energy is available is to have the microcontroller monitor the voltage on its power bus using one of its internal A/D converters.

# CBC-EVAL-10B EnerChip CC EH Evaluation Kit

---

## Frequently Asked Questions

- Q: I am not sure if I have enough input power to charge the EnerChip batteries?  
A: Measure the voltage on pin 1 of header connector J7. If the voltage is 4.1V, the EnerChips (and external rechargeable battery connected to J7, if any) are being charged. If the voltage is not 4.1V (+/- 50mV), there is insufficient power to charge the batteries.
- Q: What if I short-circuit the output?  
A: The disconnect circuit will disconnect the EnerChip devices from the output after the capacitor is discharged below about 3.0V. This prevents the EnerChips from being discharged too deeply. The EnerChip cell will automatically reconnect after the capacitor is recharged.
- Q: What happens if I want to run a larger pulse current application?  
A: See application note AN-1025. The output capacitor can be sized to drive almost any load as long as the duration is not too long. AN-1025 describes how to calculate the capacitor size.
- Q: What happens if the EnerChip is short-circuited? Will it explode or leak harmful chemicals?  
A: No. There are no harmful chemicals to leak and the energy storage cells will not explode.
- Q: How long will the CBC-EVAL-10B module operate with no ambient light?  
A: This depends on many factors, including load power consumption, EnerChip state-of-charge, operating temperature, etc. The EnerChips on the CBC51100 module provide 100 $\mu$ Ah of discharge capacity when fully charged.
- Q: How long will the CBC-EVAL-10 module last if I use it every day and input power is available most of the time?  
A: The CBC-EVAL-10 module should last at least 10 years.
- Q: How long will the two EnerChips on the CBC51100 module hold a charge, assuming no input power?  
A: The self-discharge of the EnerChip is a function of several parameters, including temperature. Self-discharge specifications can be found in the product data sheets at <http://www.cymbet.com/content/products-resource-docs.asp>.
- Q: What happens if the EnerChip is left in a discharged state for a long period of time?  
A: Leaving the EnerChip in a discharged state is not detrimental to its performance.
- Q: I see no voltage on VOUT.  
A: Make sure there is sufficient input power to operate the CBC3150 charge pump and that the output is not short-circuited.
- Q: Will the CBC-EVAL-10B disconnect the EnerChips before they become too deeply depleted?  
A: Yes, the CBC3150 on the daughter board of the CBC-EVAL-10B has a cutoff circuit that will prevent the EnerChips from being damaged due to over-discharge. However, repeatedly operating the system in a mode that allows the cutoff circuit to be invoked at deep discharge will cause premature capacity fade and shorter product life. If it is anticipated that the low voltage cutoff point will be reached, such as when you are planning to ship a charged product, it is better to put the system into a high power mode to force cutoff at a higher state-of-charge, thereby prolonging the life of the EnerChips and allowing the product to arrive in a charged state for a better out-of-box experience.



# CBC-EVAL-10B EnerChip CC EH Evaluation Kit

## Power Conversion Efficiency Considerations

System factors such as PV cell properties; ambient light; input and output capacitor sizes; battery state-of-charge; and CBC3150 VMODE/input POR peak power voltage point setting will all affect the duty cycle of the CBC3150 charge pump and system power conversion efficiency.

The CBC3150 has a built-in latency of about 200ms with respect to the timing of RESET/ being asserted low after the charge pump is disabled. For optimum power conversion efficiency, size the input capacitor so that it will only charge one or two tenths of a volt during that 200ms period under the lowest anticipated lighting condition - that is, where the PV cell gives its lowest power output.

For example, suppose the PV cell at 200Lux can deliver 50 $\mu$ A at a maximum power point of 3.0V. Transposing the standard equation  $I = C \times dv/dt$ , the input capacitor can be sized as  $C = 50\mu A \times 200ms/100mV = 100\mu F$  of capacitance. When the charge pump runs, it will quickly pump the capacitor to the switching point. When the charge pump stops during the 200ms latency time, the capacitor will not charge above the maximum power point. At higher light intensity, the efficiency is less important and thus the capacitor does not need to be oversized to maintain operation at the peak power point of the PV cell.

## Ordering Information - Products Discontinued and Not Available

EnerChip Part Number	Description	Notes
CBC-EVAL-10B	EnerChip CC Energy Harvester Evaluation Kit	Contains Solar Cell Panel and CBC51100 Module
CBC3150-D9C	EnerChip CC with Integrated Power Management	Packaged in Tape and Reel or Tubes
CBC050-M8C	EnerChip 50 $\mu$ Ah Solid State Battery	Packaged in Tape and Reel or Tubes

### Disclaimer of Warranties; As Is

The information provided in this data sheet is provided "As Is" and Cymbet Corporation disclaims all representations or warranties of any kind, express or implied, relating to this data sheet and the Cymbet battery product described herein, including without limitation, the implied warranties of merchantability, fitness for a particular purpose, non-infringement, title, or any warranties arising out of course of dealing, course of performance, or usage of trade. Cymbet battery products are not approved for use in life critical applications. Users shall confirm suitability of the Cymbet battery product in any products or applications in which the Cymbet battery product is adopted for use and are solely responsible for all legal, regulatory, and safety-related requirements concerning their products and applications and any use of the Cymbet battery product described herein in any such product or applications.

**Cymbet, the Cymbet Logo and EnerChip are trademarks of Cymbet Corporation. All Rights Reserved.  
EnerChip products and technology are covered by one or more patents or patents pending.**