

Photologic® Optical Flag Switch

OPB685-3, OPB686, OPB687, OPB695,
OPB696, OPB697, OPB698 Series

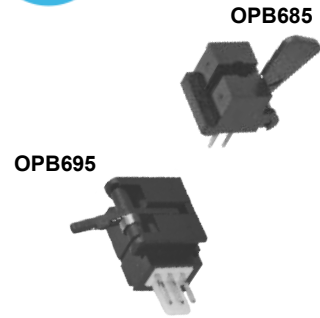

Features:

- Photologic® output
- Four output options
- Mechanical switch replacement
- Printed circuit board mounting (OPB685-3)
- 2.5mm, 3-pin connector mates with Molex connector 5051 series housing and 4809 series terminal for OPB695 Series

Description:

Each **OPB685-3** and **OPB695** series flag switch consists of an infrared emitting diode and a monolithic integrated circuit that incorporates a photodiode, a linear amplifier and a Schmitt trigger. A lever arm actuated flag interrupts the light beam, which switches the output between states that can readily drive logic gates.

The **OPB695** series is designed to easily snap mount into a 0.037" ± 0.001" (0.940 mm ± 0.025 mm) thick material with a rectangular opening of 0.320" ± 0.003" x 0.472" (8.13 mm x 11.99 mm) minimum. Insertion into the punched side of metal is recommended.

Devices in these series feature TTL/LSTTL compatible logic level output that can drive up to 10 TTL loads over a voltage range from 4.5 V to 16 V.

Customized lever arms and spring torques can be designed for specific applications for each of the devices.

Custom electrical, wire, cabling and connectors are available. Contact your local representative or OPTEK for more information.

Applications:

- Mechanical switch replacement
- Speed indication (tachometer)
- Mechanical limit indication
- Edge sensing

Ordering Information				
Part Number	LED Peak Wavelength	Sensor Photologic®	Flag Travel Degrees Max	Lead Length / Spacing or Connector
OPB685-3	890 nm	10K Pull-Up	59°	Mates with 3 Pin—Molex 5051 (22-01-1032) Housing & 4809 (08-70-0069) Terminals
OPB686		Open Collector		
OPB687		Inv. 10K Pull-Up		
OPB695AZ		10K Pull-Up	70°	
OPB696AZ		Open Collector		
OPB697AZ		Inv. 10K Pull-Up		
OPB698CZ		Inv. Open Collector		



RoHS

General Note

TT Electronics reserves the right to make changes in product specification without notice or liability. All information is subject to TT Electronics' own data and is considered accurate at time of going to print.

OPTEK Technology, Inc.
1645 Wallace Drive, Carrollton, TX 75006 | Ph: +1 972 323 2200
www.optekinc.com | www.ttelectronics.com

Photologic® Optical Flag Switch

OPB685-3, OPB686, OPB687, OPB695,
OPB696, OPB697, OPB698 Series



OPB685-3, OPB686, OPB687,

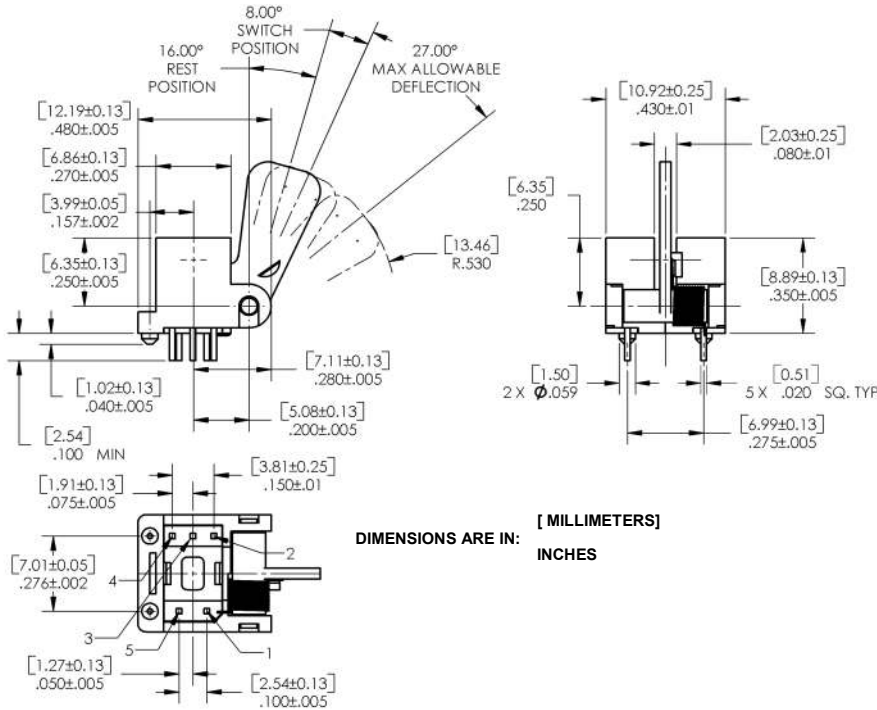

Pin #	Description
1	Anode
5	Cathode
2	Ground
3	Output
4	V _{CC}

[MILLIMETERS]
DIMENSIONS ARE IN:
INCHES

OP695, OPB696, OPB697, OPB698

Part Number	Max. Torque (Grams)
OPB685-3	3.0
OPB686	1.5
OPB687	1.5
OPB695	1.5
OPB696	1.5
OPB697	1.5
OPB698	1.5

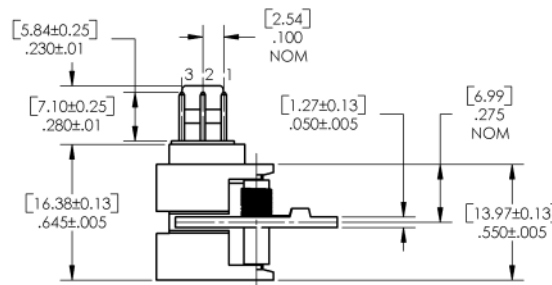

Pin #	OPB695
1	V _{CC}
2	Output
3	Ground

Torque is measured at the end of the arm from the resting position to the switching point of the flag

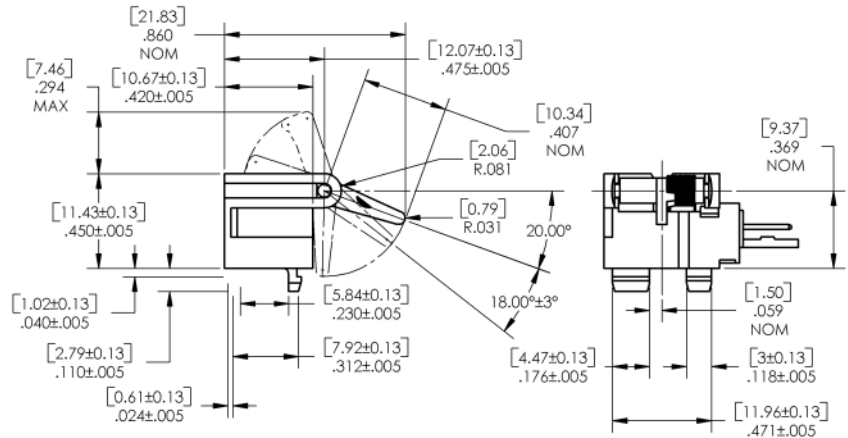

General Note
TT Electronics reserves the right to make changes in product specification without notice or liability. All information is subject to TT Electronics' own data and is considered accurate at time of going to print.

OPTEK Technology, Inc.
1645 Wallace Drive, Carrollton, TX 75006 | Ph: +1 972 323 2200
www.optekinc.com | www.ttelectronics.com

Photologic® Optical Flag Switch

OPB685-3, OPB686, OPB687, OPB695,
OPB696, OPB697, OPB698 Series



Absolute Maximum Ratings ($T_A = 25^\circ\text{C}$ unless otherwise noted)	
Storage & Operating Temperature Range	-40°C to +100°C
Lead Soldering Temperature [1/16 inch (1.6mm) from the case for 5 sec. with soldering iron] ⁽¹⁾	260°C
Input Diode	
Reverse Voltage	2.0 V
Continuous Forward Current	50 mA
Peak Forward Current	3.0 A
Total Device Power Dissipation ⁽²⁾	100 mW
Output Photologic®	
Supply Voltage, V_{CC}	18 V
Duration of Output Short to V_{CC}	1 second
Voltage at Output	30 V
Low Level Output Current (sinking)	16 mA
Power Dissipation ^{(3) (4)}	240 mW

Notes:

- (1) RMA flux is recommended. Duration can be extended to 10 seconds maximum when flow soldering.
- (2) Derate linearly 1.33 mW/°C above 25° C.
- (3) Derate linearly 2.00 mW/°C above 25° C (OPB680, OPB680-20, OPB690Z).
- (4) Derate linearly 2.50 mW/°C above 25° C (OPB685-3, OPB686, OPB687, OPB695, OPB696, OPB697, OPB698).

General Note

TT Electronics reserves the right to make changes in product specification without notice or liability. All information is subject to TT Electronics' own data and is considered accurate at time of going to print.

OPTEK Technology, Inc.
1645 Wallace Drive, Carrollton, TX 75006 | Ph: +1 972 323 2200
www.optekinc.com | www.ttelectronics.com

Photologic® Optical Flag Switch

OPB685-3, OPB686, OPB687, OPB695,
OPB696, OPB697, OPB698 Series



OPB685-3 and OPB695 Series

OPB685-3, OPB695 Buffered 10K Pull-Up

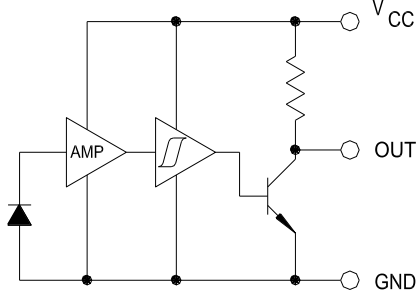

OPB686, OPB696 Buffered Open-Collector

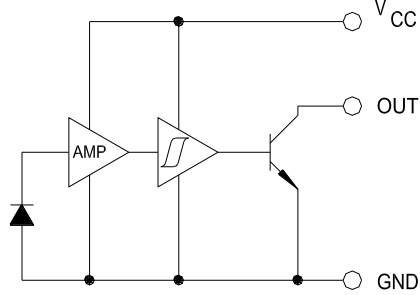

OPB687, OPB697 Inverted 10K Pull-Up

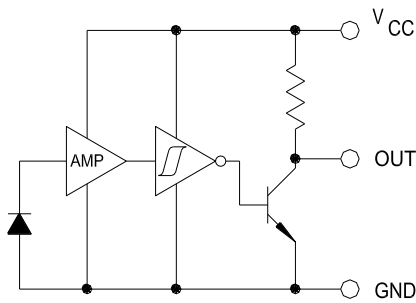

OPB698 Inverted Open-Collector

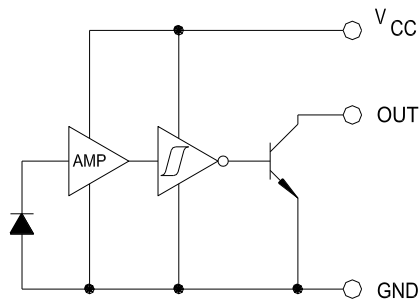

General Note

TT Electronics reserves the right to make changes in product specification without notice or liability. All information is subject to TT Electronics' own data and is considered accurate at time of going to print.

OPTEK Technology, Inc.
1645 Wallace Drive, Carrollton, TX 75006 | Ph: +1 972 323 2200
www.optekinc.com | www.ttelectronics.com

Photologic® Optical Flag Switch

OPB685-3, OPB686, OPB687, OPB695,
OPB696, OPB697, OPB698 Series



Electrical Characteristics (T _A = 25° C unless otherwise noted)							
SYMBOL	PARAMETER	MIN	TYP	MAX	UNITS	TEST CONDITIONS	
Input Diode							
V _F	Forward Voltage	-	-	1.6	V	I _F = 10 mA	
I _R	Reverse Current	-	-	100	μA	V _R = 3 V	
Output Photologic® Sensor							
V _{CC}	Operating DC Supply Voltage						
	OPB685-3 Series	4.5	-	16.0	V		
	OPB695-698A	4.5	5.0	8.0			
	OPB695-698B	8.0	12.0	13.5			
OPB695-698C	13.5	15.0	16.0				
I _{CC}	Operating DC Supply Current OPB695-698A/B/C	-	20	30	mA		
I _{CCL}	Low Level Supply Current: Buffered 10k Pull-Up	OPB685-3	-	5.5	12	mA	V _{CC} = 16 V, I _F = 0 mA (no load on output)
	Buffered Open-Collector	OPB686	-	4.0	12		
	Inverted 10k Pull-Up	OPB687	-	6.5	12		
I _{CCH}	High Level Supply Current: Buffered 10k Pull-Up	OPB685-3	-	5.0	12	mA	V _{CC} = 16 V, I _F = 10 mA (no load on output)
	Buffered Open-Collector	OPB686	-	5.0	12		
	Inverted 10k Pull-Up	OPB687	-	4.0	12		
V _{OL}	Low Level Output Voltage ⁽¹⁾ : Buffered 10k Pull-Up	OPB685-3	-	-	0.4	V	V _{CC} = 4.5 V, I _{OL} = 16 mA, I _F = 0 V _{CC} = 4.5 V to 8 V, I _{OL} = 16 mA V _{CC} = 8.5 V to 13 V, I _{OL} = 16 mA V _{CC} = 13.5 V to 16 V, I _{OL} = 16 mA
	Buffered Open-Collector	OPB686	-	-	0.4		
		OPB695	-	-	0.4		
		OPB696A/B/C	-	-	0.4		
	Inverted 10k Pull-Up ⁽²⁾	OPB685-3	-	-	0.4	V	V _{CC} = 4.5 V, I _{OL} = 16 mA, I _F = 0 V _{CC} = 4.5 V to 8 V, I _{OL} = 16 mA V _{CC} = 8.5 V to 13 V, I _{OL} = 16 mA V _{CC} = 13.5 V to 16 V, I _{OL} = 16 mA
	Inverted Open-Collector	OPB686	-	-	0.4		
	OPB695	-	-	0.4			
	OPB696A/B/C	-	-	0.4			
V _{OH}	High Level Output Voltage ⁽²⁾ : Buffered 10k Pull-Up	V _{CC}	-	-	-	V	I _{OH} = 100 μA, I _F = 10 mA
	Inverted 10k Pull-Up ⁽¹⁾ Inverted Open-Collector	V _{CC}	-	-	-	V	I _{OH} = 100 μA, I _F = 0 mA
I _{OH}	High Level Output Current ⁽²⁾ : Buffered Open-Collector	OPB686	-	-	100	μA	V _{CC} = 16 V, I _F = 10 mA, V _{CH} = 30 V V _{CC} = 4.5 V to 8 V, V _{OH} = 30 V V _{CC} = 8.5 V to 13 V, V _{OH} = 30 V V _{CC} = 13.5 V to 16 V, V _{OH} = 30 V
		OPB696A	-	-	100		
		OPB696B	-	-	100		
		OPB696C	-	-	100		
	Inverted 10k Pull-Up ⁽¹⁾	OPB698A	-	-	100	μA	V _{CC} = 4.5 V to 8 V, V _{OH} = 30 V ⁽¹⁾ V _{CC} = 8.5 V to 13 V, V _{OH} = 30 V ⁽¹⁾ V _{CC} = 13.5 V to 16 V, V _{OH} = 30 V ⁽¹⁾
	OPB698B	-	-	100			
	OPB698C	-	-	100			

General Note

TT Electronics reserves the right to make changes in product specification without notice or liability. All information is subject to TT Electronics' own data and is considered accurate at time of going to print.

OPTEK Technology, Inc.
1645 Wallace Drive, Carrollton, TX 75006 | Ph: +1 972 323 2200
www.optekinc.com | www.ttelectronics.com

Photologic® Optical Flag Switch

OPB685-3, OPB686, OPB687, OPB695,
OPB696, OPB697, OPB698 Series



Electrical Characteristics (T _A = 25° C unless otherwise noted)						
SYMBOL	PARAMETER	MIN	TYP	MAX	UNITS	TEST CONDITIONS
Output Photologic® Sensor (continued)						
I _{F(+)}	LED Positive-Going Threshold Current OPB685-3—687	0.1	1.8	10	mA	V _{CC} = 5 V
I _{F(+)} /I _{F(-)}	Hysteresis OPB685-3	1.0	1.2	1.6	mA	V _{CC} = 5 V
t _r ,t _f	Rise Time, Fall Time	-	30	-	ns	
t _{PLH} ,t _{PHL}	Propagation Delay Low-High & High-Low: Buffer, 10k Pull-Up OPB685-3	-	1 (LH)	-	μs	V _{CC} = 5 V, I _F = 0 or 10 mA R _L = 300 Ω, DC = 50% f = 10 kHz
	Buffer, Open-Collector OPB686	-	2 (HL)	-	μs	
	Inverter, 10k Pull-Up OPB687	-	2 (LH)	-	μs	

Notes:

- (1) Test requires lever arm in “blocked” position.
- (2) Test requires lever arm in “unblocked” position

General Note

TT Electronics reserves the right to make changes in product specification without notice or liability. All information is subject to TT Electronics’ own data and is considered accurate at time of going to print.

OPTEK Technology, Inc.
1645 Wallace Drive, Carrollton, TX 75006 | Ph: +1 972 323 2200
www.optekinc.com | www.ttelectronics.com

