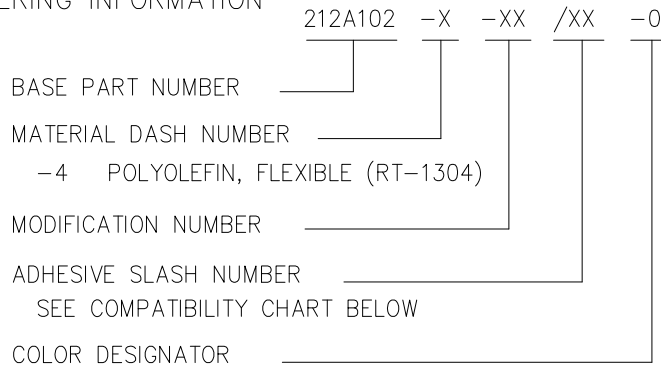

TABLE OF DIMENSIONS								
PART DESCRIPTION	H		P +.05 -.07 b	R ±.05 b	S ±.10 b	T ±.01 b	U ±.010 b	W ±.005 b
	MIN	MAX						
	a	b						
212A102	3.00 [76,2]	1.00 [25,4]	2.93 [74,4]	1.35 [34,3]	1.10 [27,9]	.60 [15,2]	.225 [5,7]	.030 [0,76]

NOTES:

- ALL DIMENSIONS ARE IN  $\frac{\text{INCHES}}{\text{[MILLIMETERS]}}$
- DIMENSIONS APPEARING IN TABLE ARE AS FOLLOWS:  
a – AS SUPPLIED; b – AFTER UNRESTRICTED RECOVERY
- ORDERING INFORMATION



**CUSTOMER DRAWING**

			Raychem Molded Parts 300 Constitution Drive Menlo Park, CA. 94025, U.S.A.		TITLE:  <b>BOOT, DUST COVER</b>		
Unless otherwise specified dimensions are in inches. Metric dimensions are shown in brackets				DOCUMENT NO.:  <b>212A102</b>			
Tyco Electronics reserves the right to amend this drawing at any time. Users should evaluate the suitability of the product for their application.				REV.: <b>D</b>		DATE: <b>February 23, 2011</b>	
REVISED BY: <b>YUNGUYEN</b>	CAGE CODE: <b>06090</b>	ECO #: <b>ECO-11-003640</b>	File: <b>212A102.doc</b>	SCALE: <b>None</b>	SIZE: <b>A</b>	SHEET: <b>1 of 1</b>	