

THIS DRAWING IS UNPUBLISHED. RELEASED FOR PUBLICATION
 © COPYRIGHT - By - ALL RIGHTS RESERVED.

REVISIONS					
P	LTR	DESCRIPTION	DATE	DWN	APVD
A12		REVISED PER ECO-17-001761	10MAY2017	RK	AS

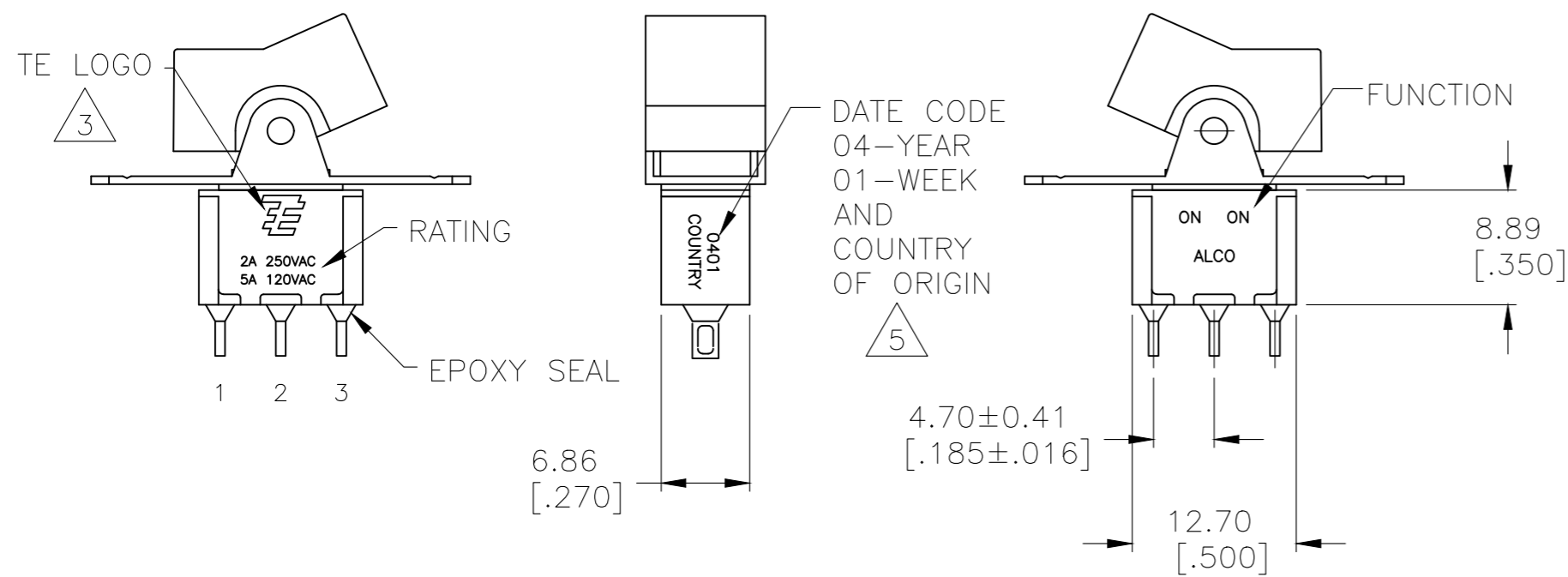

- 1 ALL MATERIALS AND FINISHES SHALL COMPLY WITH EU DIRECTIVE 2002/95/EC OF 27JAN2003 (ROHS).
- 2 G CONTACT OPTION CAN BE USED FOR SIGNAL OR POWER LEVEL SWITCHING. IF SWITCH IS USED AT LEVELS EXCEEDING .4VA @ 20V AC/DC, SWITCH IS RENDERED FOR POWER SWITCHING ONLY DUE TO ARC REMOVAL OF GOLD PLATING. RATING MARKED ON SWITCH IS 2A 250VAC, 5A 120VAC.
- 3 TE CONNECTIVITY LOGO PER PER TEC-202-36.
- 5 DATE CODE AND COUNTRY OF ORIGIN MAY APPEAR ON EITHER SIDE OF SWITCH.
- 6 PANEL MOUNT BRACKET SUPPLIED WITH TERMINALS W, Z AND Z3 ONLY.
- 7 ACTUATOR MARKED
- 8 ACTUATOR MARKED
- 9 ACTUATOR MARKED
- 10 ALL LOGO, RATING, DATE CODE, AND FUNCTION MARKINGS TO BE LASER MARKED.
- 11 OBSOLETE
- 12 GRAY ACTUATOR WITH MODIFIED BRACKET (SUPPORT BRACKET TRIMMED PARALLEL TO THE PCB)

FUNCTION CHART			
FUNCTION			
	1 2 3	1 2 3	1 2 3
01	ON	NONE	ON
03	ON	OFF	ON
05	(ON)	OFF	(ON)
07	ON	OFF	(ON)
08	ON	NONE	(ON)
TERMINALS CONNECTED	2-3	---	1-2

NONE: NO MECHANICAL POSITION
 OFF: MECHANICAL POSITION WITH NO ELECTRICAL CONNECTION
 (ON): MOMENTARY ACTION

SPECIFICATIONS	
RATING, B CONTACTS	.4VA MAX @20V MAX. AC OR DC
RATING, G CONTACTS--SEE NOTE 2	.4VA MAX @20V MAX. AC OR DC OR 5A @120 VAC OR 28 VDC (RESISTIVE)
	2A @250 VAC (RESISTIVE)
RATING, Q CONTACTS	5A @120 VAC OR 28 VDC (RESISTIVE)
	2A @250 VAC (RESISTIVE)
ELECTRICAL LIFE	6,000 CYCLES AT RATED LOAD
CONTACT RESISTANCE	10 MILLIOHMS MAX INITIAL @ 2-4VDC, 100MA
INSULATION RESISTANCE	1,000 MEGOHMS MIN
DIELECTRIC WITHSTANDING VOLTAGE	1,000 V RMS AT SEA LEVEL
OPERATING TEMPRATURE	-30C TO 85C

PART NUMBER SEQUENCE CHART							
MODEL	FUNCTION	ACTUATOR	TERMINAL	CONTACT	ACTUATOR COLOR	BEZEL COLOR	ROHS
A1							04
	01	J1	A	B	0 BLACK (STD)	0 BLACK (STD)	
	03	J3	AV2	G	1 BROWN	1 BROWN	
	05	J50	C	Q	2 RED	2 RED	
	07	J51	V3		3 ORANGE	3 ORANGE	
	08	J52	V4		4 YELLOW	4 YELLOW	
		J2	V6		5 GREEN	5 GREEN	
		J4	V7		6 BLUE	6 BLUE	
		J60	W		8 GRAY	8 GRAY	
		J61	W4		9 WHITE	9 WHITE	
		J62	Z				
			Z3				

THIS DRAWING IS A CONTROLLED DOCUMENT.

DWN	M.BINNER	06JAN05
CHK	M.ZITTO	06JAN05
APVD	M.ZITTO	06JAN05

TE Connectivity

GEMINI A SERIES ROCKER SWITCH
SINGLE POLE

SIZE	CAGE CODE	DRAWING NO	RESTRICTED TO
A2	00779	C-1571986	-

CUSTOMER DRAWING SCALE 2:1 SHEET 1 of 5 REV A12

THIS DRAWING IS UNPUBLISHED. RELEASED FOR PUBLICATION
 © COPYRIGHT - By - ALL RIGHTS RESERVED.

REVISIONS				
P	LTR	DESCRIPTION	DATE	APVD
-	-	SEE SHEET 1	-	-

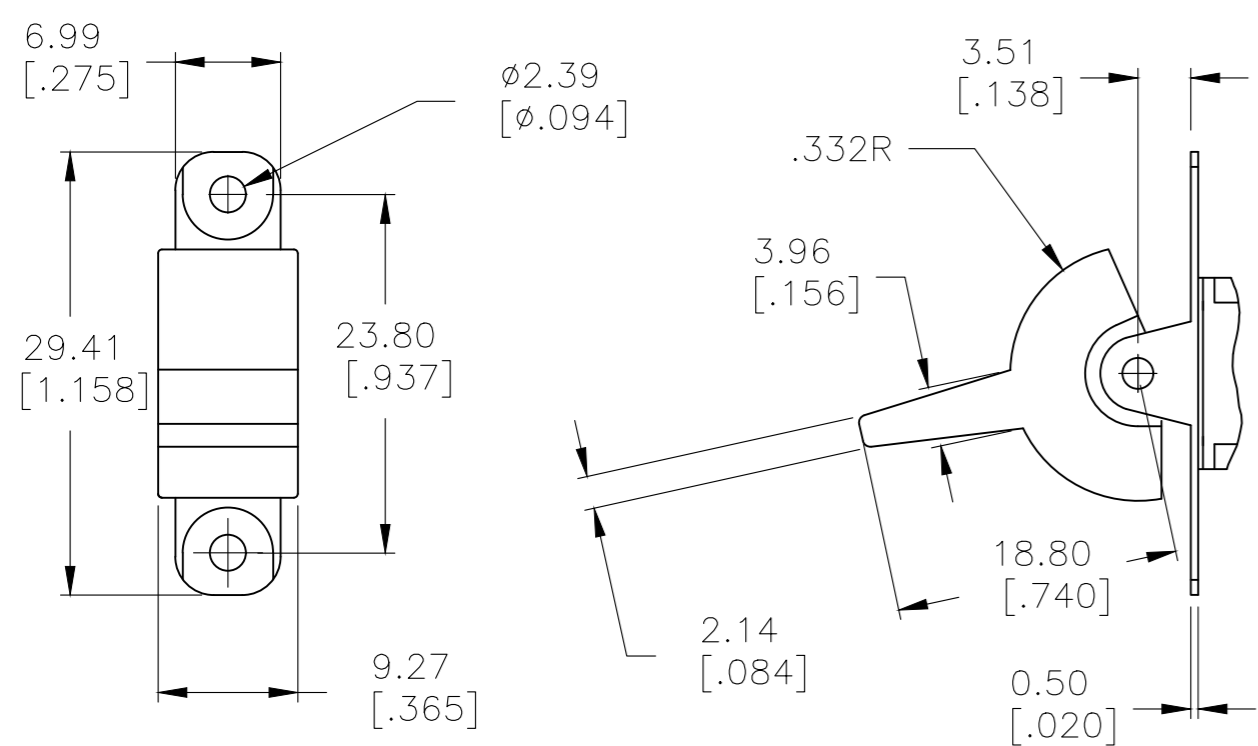

J2 SMALL

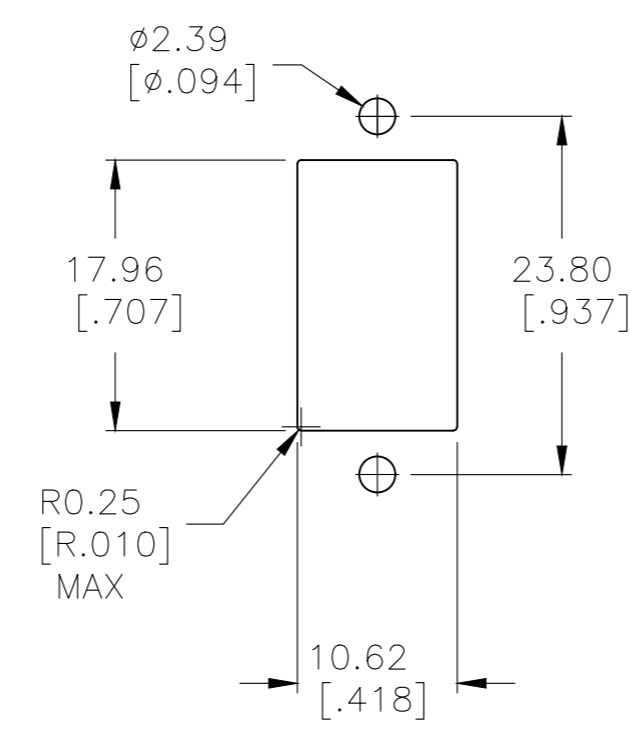

J4 LARGE

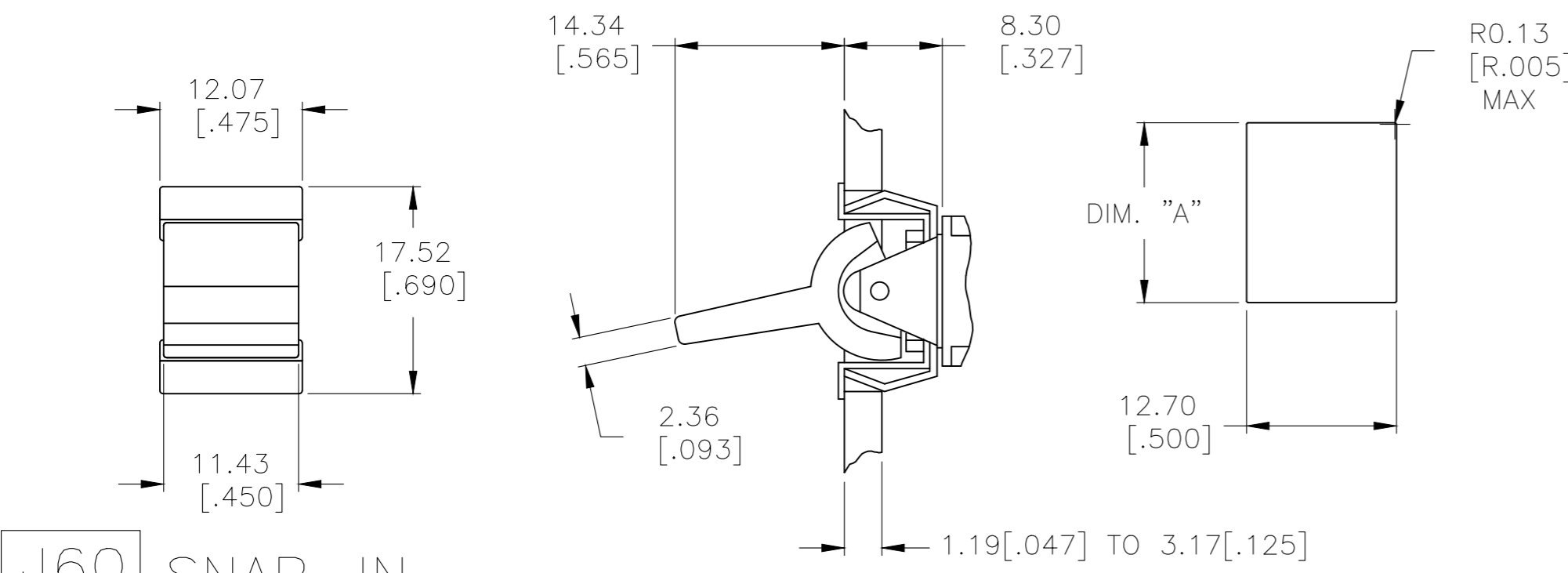
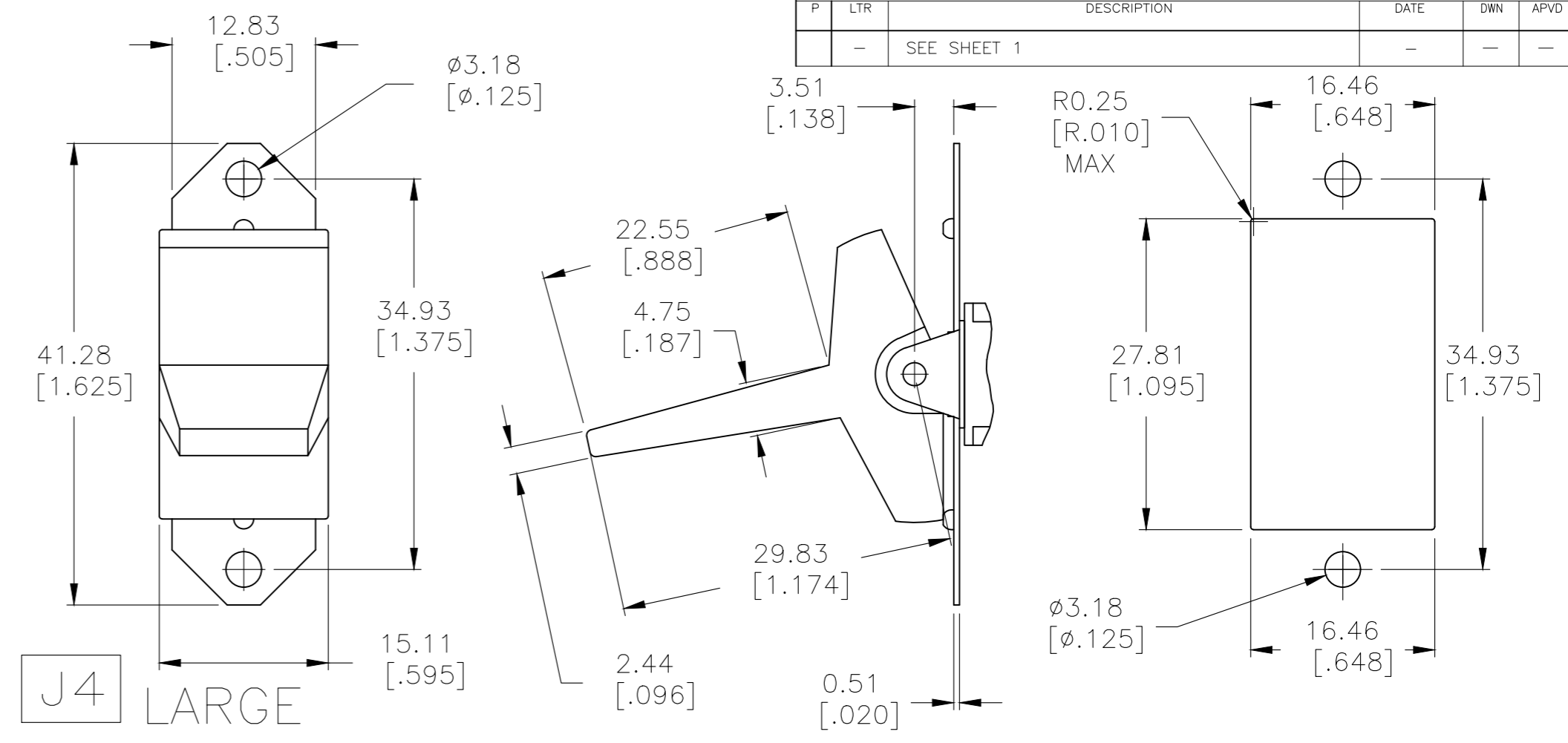

J60 SNAP-IN

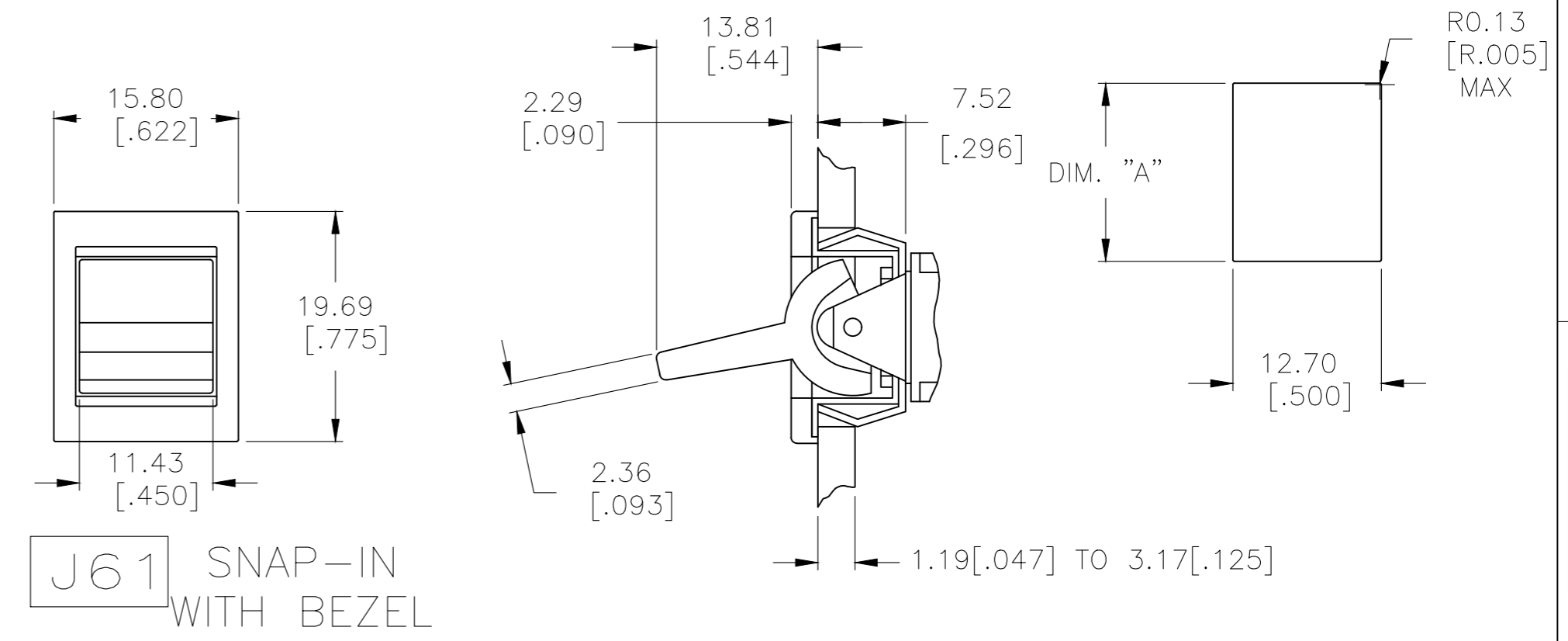

J61 SNAP-IN WITH BEZEL

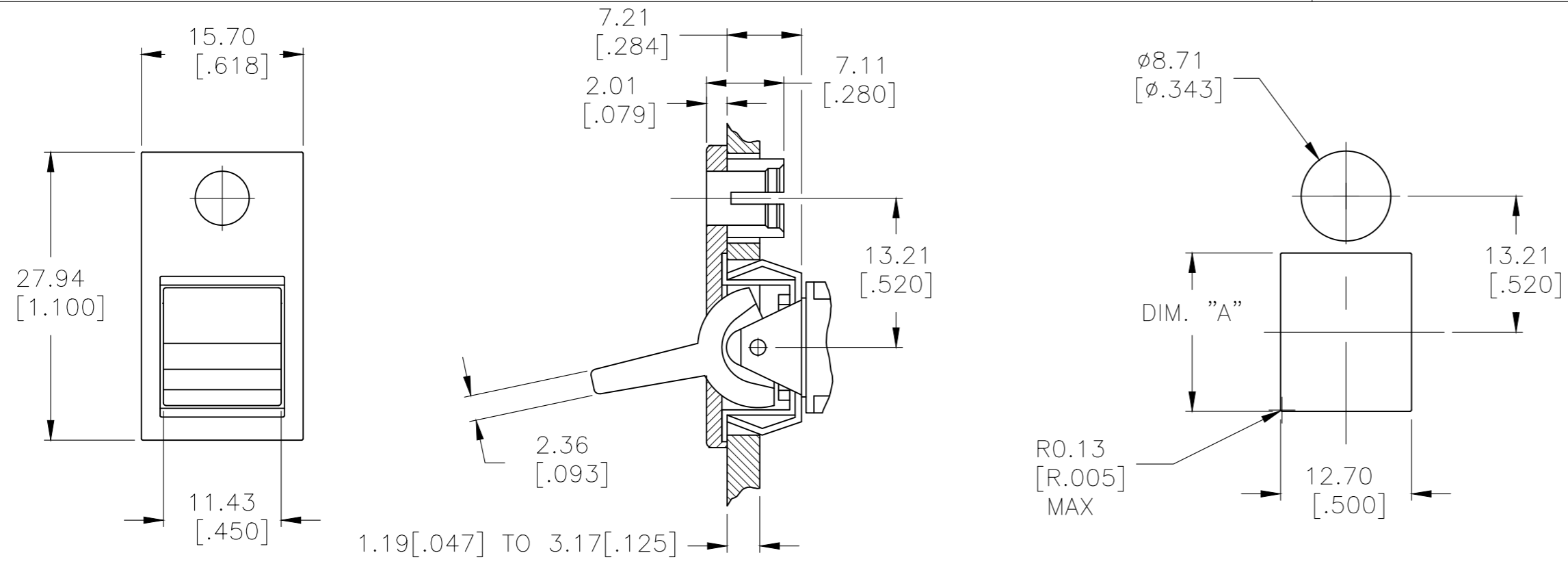

J62 SNAP-IN WITH BEZEL/L.E.D.

NOTE: L.E.D. NOT SUPPLIED

1.52 [.060] - 3.17 [.125]	15.75 [.620] - 15.87 [.625]
1.19 [.047] - 1.50 [.059]	15.72 [.619]
PANEL THICKNESS	DIM "A"

THIS DRAWING IS A CONTROLLED DOCUMENT.		DWN	M.BINNER	06JAN05
DIMENSIONS: mm [INCHES]		CHK	M.ZITTO	06JAN05
TOLERANCES UNLESS OTHERWISE SPECIFIED:		APVD	M.ZITTO	06JAN05
0 PLC	± -	PRODUCT SPEC		
1 PLC	± -	APPLICATION SPEC		
2 PLC	± -	WEIGHT -		
3 PLC	± 0.25[0.01]	SIZE A2		
4 PLC	± -	CAGE CODE 00779		
ANGLES	± 4°	DRAWING NO. 1571986		
MATERIAL -	FINISH -	RESTRICTED TO -		
CUSTOMER DRAWING		SCALE 2:1		SHEET 3 OF 5
				REV A12

THIS DRAWING IS UNPUBLISHED. RELEASED FOR PUBLICATION
 © COPYRIGHT - By - ALL RIGHTS RESERVED.

REVISIONS					
P	LTR	DESCRIPTION	DATE	DWN	APVD
-	-	SEE SHEET 1	-	-	-

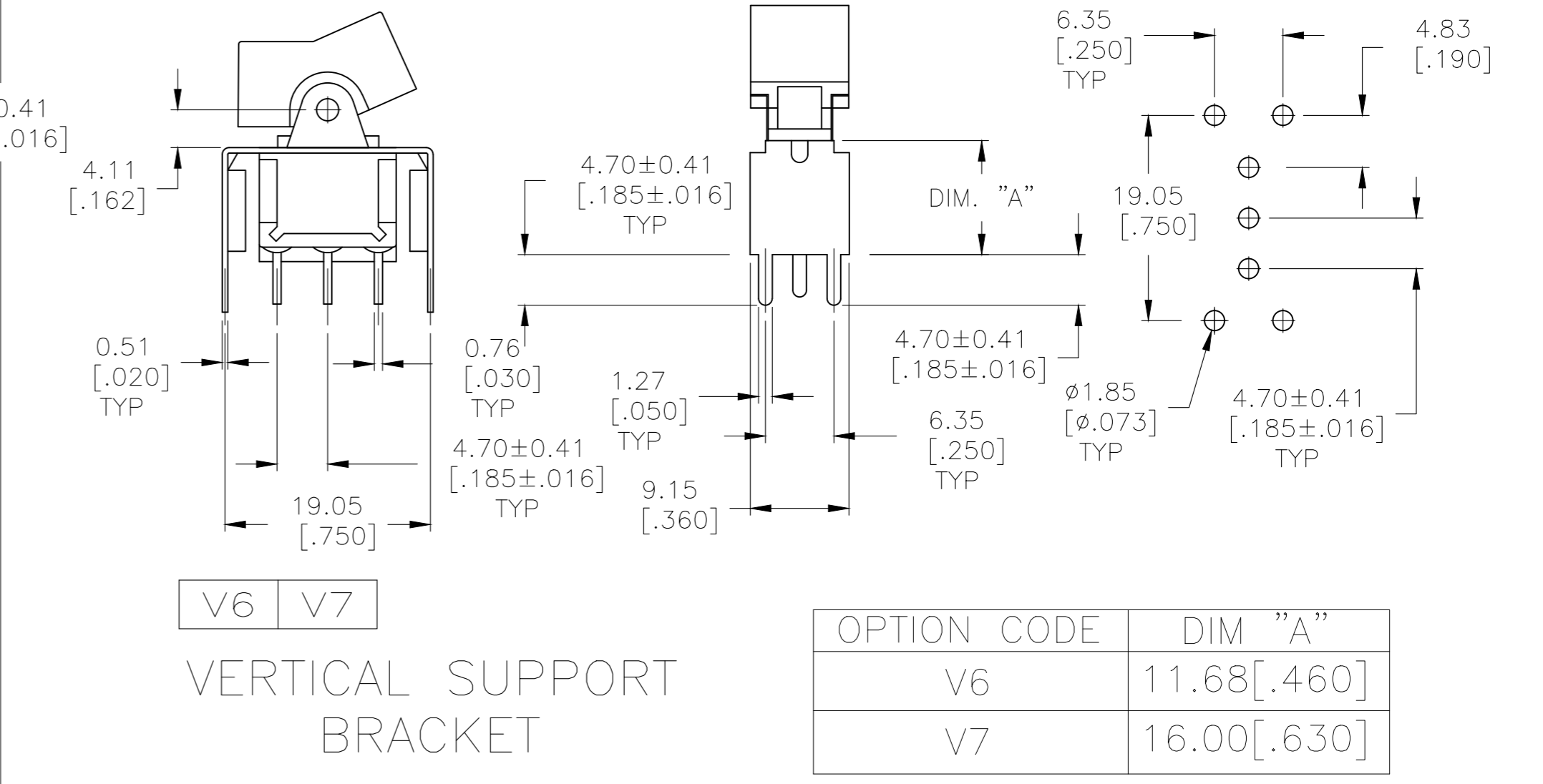
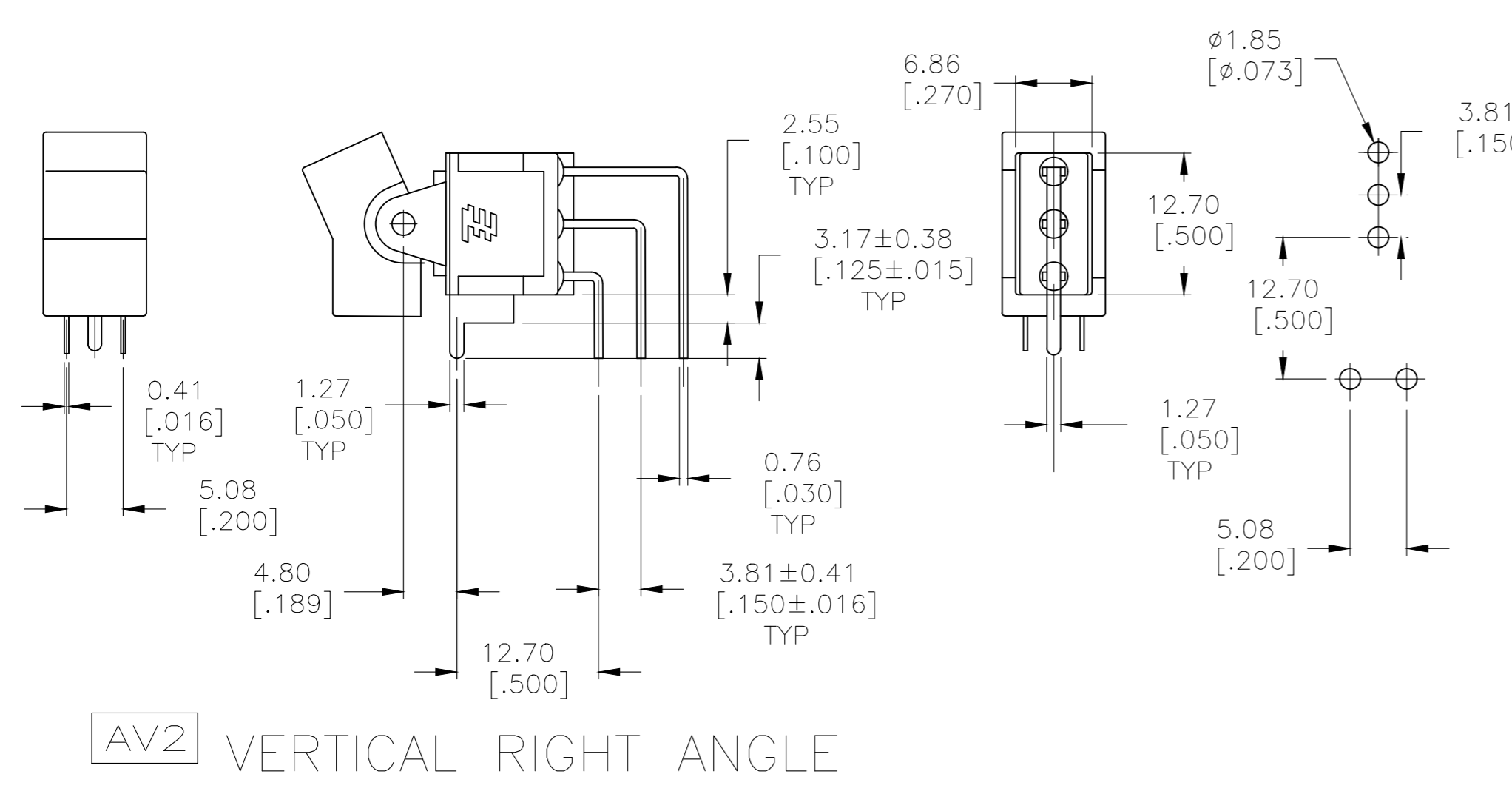
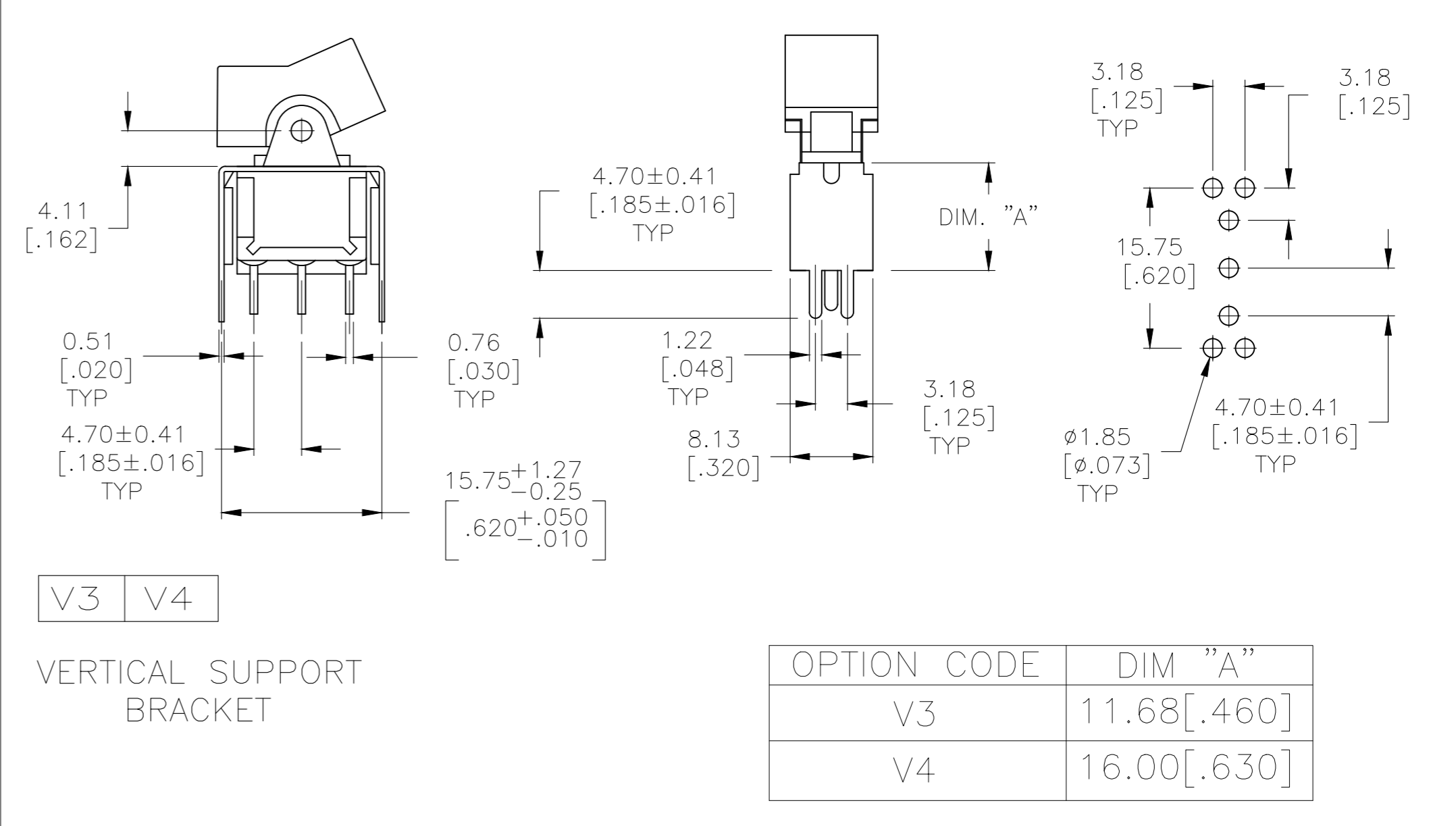
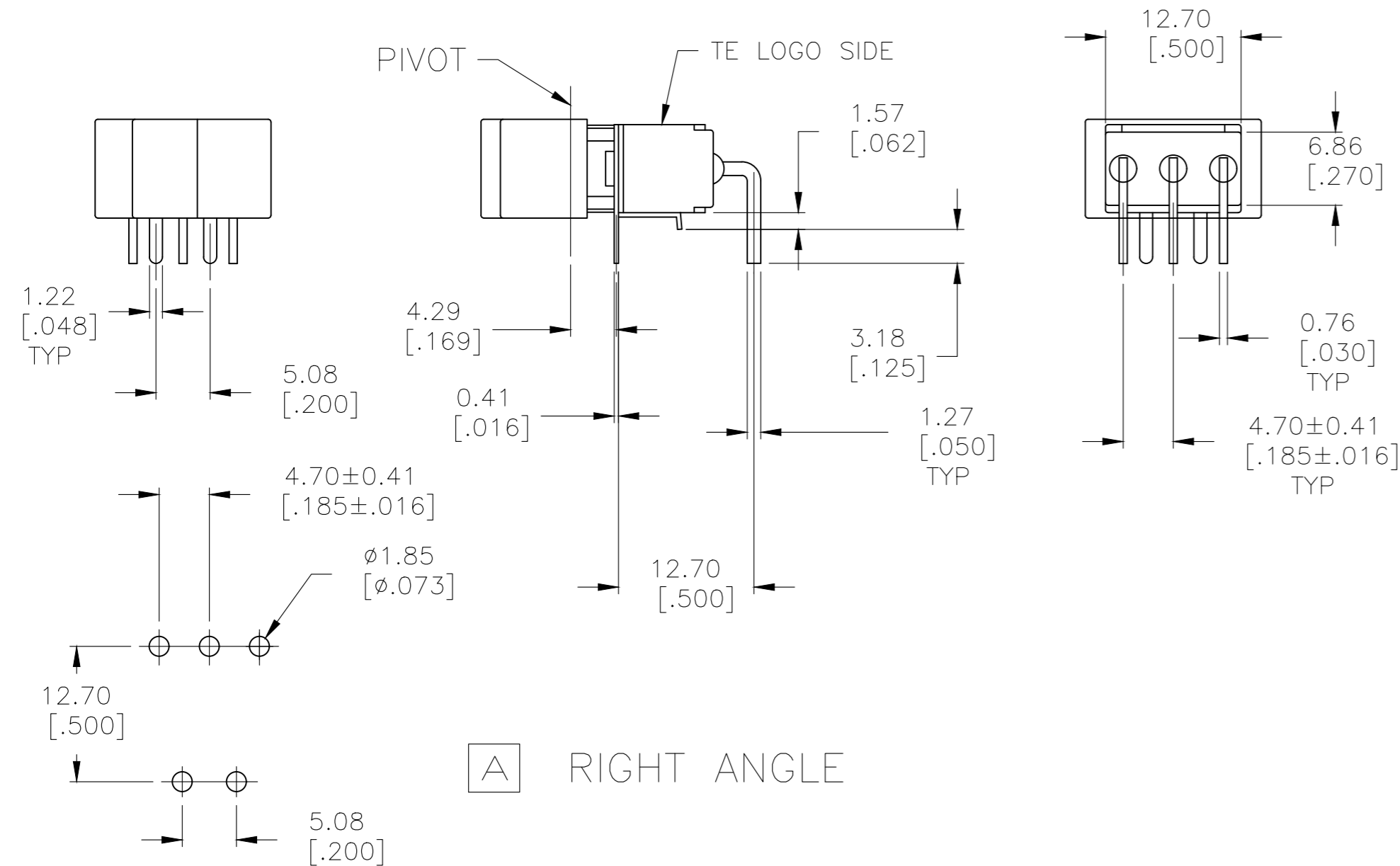

THIS DRAWING IS A CONTROLLED DOCUMENT.

DWN	M.BINNER	06JAN05
CHK	M.ZITTO	06JAN05
APVD	M.ZITTO	06JAN05

STE TE Connectivity

GEMINI A SERIES ROCKER SWITCH SINGLE POLE

SIZE	A2	CAGE CODE	00779	DRAWING NO	1571986	RESTRICTED TO	-
CUSTOMER DRAWING		SCALE	2:1	SHEET	4 OF 5	REV	A12

THIS DRAWING IS UNPUBLISHED. RELEASED FOR PUBLICATION
 © COPYRIGHT - By - ALL RIGHTS RESERVED.

REVISIONS				
P	LTR	DESCRIPTION	DATE	DWN
-	-	SEE SHEET 1	-	-

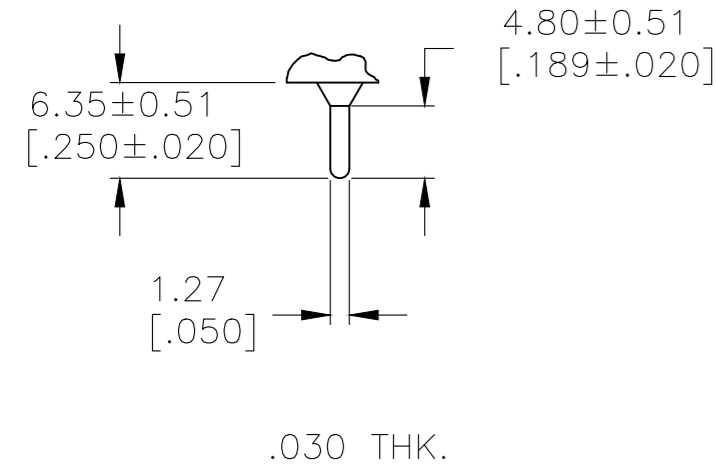

C PRINTED CIRCUIT

MATERIALS CHART		
COMPONENT NAME	BASE MATERIAL	FINISH
CASE	DAP, 30-40% GF, RED, UL94 V-0, COSMIC D72/6120F	
FRAME	304 STAINLESS STEEL	
B TERMINALS & CONTACTS	C194 COPPER	GOLD OVER NICKEL
G TERMINALS & CONTACTS	C194 COPPER	GOLD OVER SILVER
Q TERMINALS & CONTACTS	C194 COPPER	SILVER
ACTUATOR	PHENOLIC, BLACK, UL94 V-1	
ROCKER CAP	NYLON, BLACK, UL94 V-1, NYTEX MG-2012N	
BUSHING & ACTUATOR LEVER	ZINC ALLOY K2	.000100-.000150 NICKEL
SPRING	MUSIC WIRE	
SUPPORT BRACKET	C2680H BRASS	TIN
PIVOT PIN	STEEL	NICKEL
TERMINAL SEAL	EPOXY, UL94 V-1, BOOM HOUSE S-9001A	

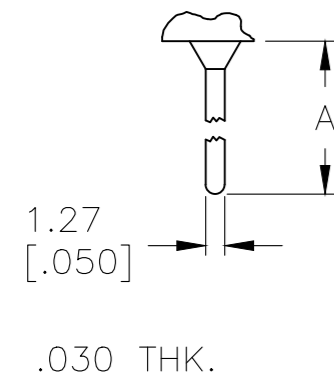

OPTION	DIM A
W	18.69[.736]
W4	26.97[1.062]

W **W4** WIRE WRAP

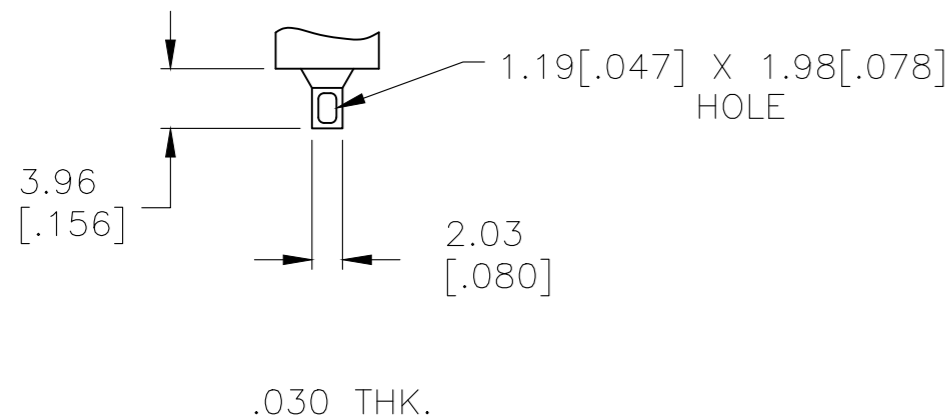

Z WIRE LUG

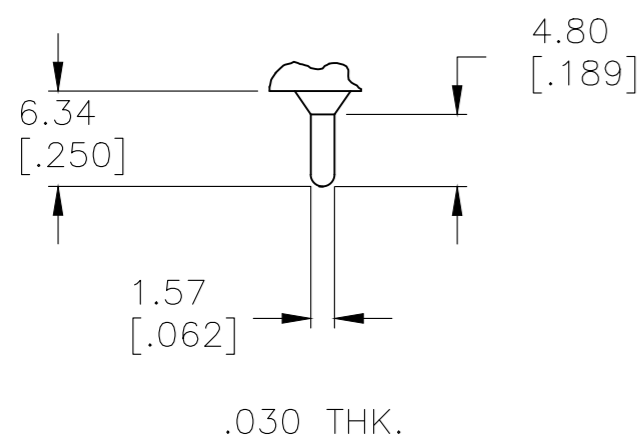

Z3 QUICK CONNECT

△	A105J1AV2Q004	5-1571986-0
△	A105J1AQ004	4-1571986-9
△	NOT ASSIGNED	4-1571986-8
△	A103J1AV2Q004MB	4-1571986-7
△	A103J61ZQ004	4-1571986-6
△	A103J51ZQ004	4-1571986-5
△	A103J3ZQ004	4-1571986-4
△	A103J2ZQ004	4-1571986-3
△	A103J2CB004	4-1571986-2
△	A103J1ZQ004	4-1571986-1
△	A103J1V3Q004	4-1571986-0
△	A103J1AV2Q004	3-1571986-9
△	A103J1AV2B004	3-1571986-8
△	NOT ASSIGNED	3-1571986-7
△	A101J61ZQ004	3-1571986-6
△	A101J51ZQ2004	3-1571986-5
△	A101J51ZQ004	3-1571986-4
△	A101J51ZB0004	3-1571986-3
△	NOT ASSIGNED	3-1571986-2
△	A101J51Z3Q0004	3-1571986-1
△	A101J51Z3G0004	3-1571986-0
△	A101J51CB0004	2-1571986-9
△	A101J50ZQ004	2-1571986-8
△	A101J50V3Q204	2-1571986-7
△	A101J50V3Q004	2-1571986-6
△	A101J50AV2Q004	2-1571986-5
△	A101J4ZQ804	2-1571986-4
△	A101J4ZQ004	2-1571986-3
△	A101J3ZQ004	2-1571986-2
△	A101J3V3Q204	2-1571986-1
△	A101J2ZQ004	2-1571986-0
△	A101J2ZB904	1-1571986-9
△	A101J2AV2Q004	1-1571986-8
△	A101J1ZQ004	1-1571986-7
△	A101J1ZB004	1-1571986-6
△	A101J1V3Q004	1-1571986-5
△	A101J1V3B004	1-1571986-4
△	A101J1CQ004	1-1571986-3
△	A101J1CG004	1-1571986-2
△	A101J1AV2Q004	1-1571986-1
△	A101J1AV2B004	1-1571986-0
△	A101J1AQ204	1571986-9
△	A101J1AQ004	1571986-8
△	A101J1AB004	1571986-7
△	NOT ASSIGNED	1571986-6
△	NOT ASSIGNED	1571986-5
△	NOT ASSIGNED	1571986-4
△	NOT ASSIGNED	1571986-3
△	NOT ASSIGNED	1571986-2
△	A101J1AB004	1571986-1

△	A101J1AV2Q004AM9	7-1571986-4
△	A101J1AV2Q004AM8	7-1571986-3
△	A101J1AV2Q004AM	7-1571986-2
△	A108J61ZQ0004	7-1571986-0
△	A108J51ZQ0004	6-1571986-9
△	A108J1ZQ004	6-1571986-8
△	A108J1V3Q004	6-1571986-7
△	A107J61ZQ0004	6-1571986-6
△	A107J51ZQ0004	6-1571986-5
△	A105J61ZQ0004	6-1571986-4
△	A105J61ZG0004	6-1571986-3
△	A105J52ZQ2004	6-1571986-2
△	A105J51ZQ0004	6-1571986-1
△	A105J4ZQ004	6-1571986-0
△	A105J3ZQ004	5-1571986-9
△	A105J3CQ2004	5-1571986-8
△	A105J3CQ004	5-1571986-7
△	A105J2ZQ004	5-1571986-6
△	A105J2AV2Q004	5-1571986-5
△	A105J2AQ004	5-1571986-4
△	A105J1ZQ004	5-1571986-3
△	A105J1V3B004	5-1571986-2
△	A105J1CQ004	5-1571986-1

THIS DRAWING IS A CONTROLLED DOCUMENT.		DWN M.BINNER	06JAN05	 TE Connectivity	NAME		GEMINI A SERIES ROCKER SWITCH SINGLE POLE		
DIMENSIONS: mm [INCHES]		CHK M.ZITTO	06JAN05		PRODUCT SPEC		SIZE	CAGE CODE	DRAWING NO
TOLERANCES UNLESS OTHERWISE SPECIFIED:		APVD M.ZITTO	06JAN05		APPLICATION SPEC		RESTRICTED TO	-	
0 PLC ± - 1 PLC ± - 2 PLC ± - 3 PLC ± 0.25[0.01] 4 PLC ± - ANGLES ± 4°		MATERIAL			FINISH		WEIGHT	-	
CUSTOMER DRAWING				SCALE 2:1		SHEET 5 OF 5		REV A12	