

PART NAME: KNOB SCALE: 1:1 DATE: 11/3/71 DR. BY NH

THIS DRAWING IS THE PROPERTY OF DAVIES MOLDING COMPANY, IS SUBMITTED SOLELY AS A DESIGN OR ENGINEERING PROJECT. WE ACCEPT NO RESPONSIBILITY WHATSOEVER FOR THE PRACTICAL APPLICATION OF THE PIECES MADE TO THIS DESIGN.

DAVIES MOLDING DESIGNERS & MANUFACTURERS OF KNOBS, HANDLES, CASES & CUSTOM PLASTIC COMPONENTS

P/N	1214-H
BASE PART	1214-05
SPRING	10476

CAD/REDRAWN : 9/15/93 : HD

(B)

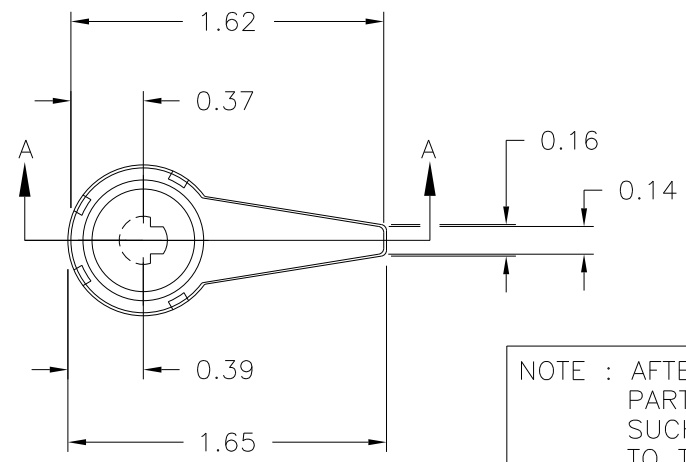

NOTE : AFTER MOLDING PROCESS OF THIS P/N # 1214-H PARTS MUST HAVE SECONDARY OPERATION SUCH AS, 10476 SPRING MUST ASSEMBLED TO THE KNOB AS PER MTG. HOLE LOCATION.

SECTION A-A

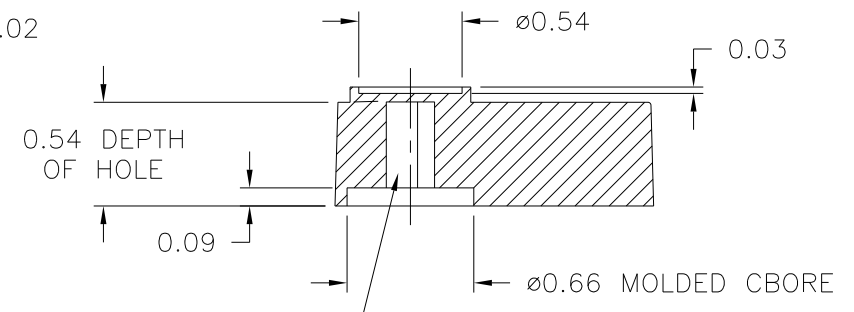
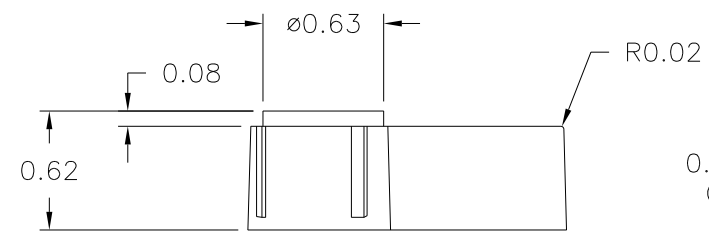
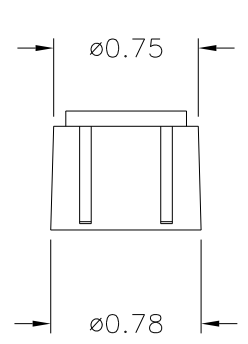

SPRING INSERT 10476 TO ACCOMMODATE ø1/4 SHAFT FLATTED TO 5/32

MATERIAL: G.P. PHENOLIC (B11)
COLOR: BLACK

TOLERANCES: UNLESS OTHERWISE SPECIFIED	DO NOT SCALE DRAWING			
DECIMALS: X.XXX ± .005 X.XX ± .015	MM: X.XX ± 0.15MM X.X ± 0.4MM	B	REMOVED "MOLDED HOLE DETAIL" VIEW, DRAWN INCORRECTLY	JAM 1/29/04
FRACTIONS ± 1/64	ANG. ± 1°	A	UPDATED TOOLBOX	LS 7/29/03
CHANGES				