

**STRAIGHT PLUG FULL CRIMP TYPE
CABLE 2.6/50 S+D**

R161.072.000
SERIES N

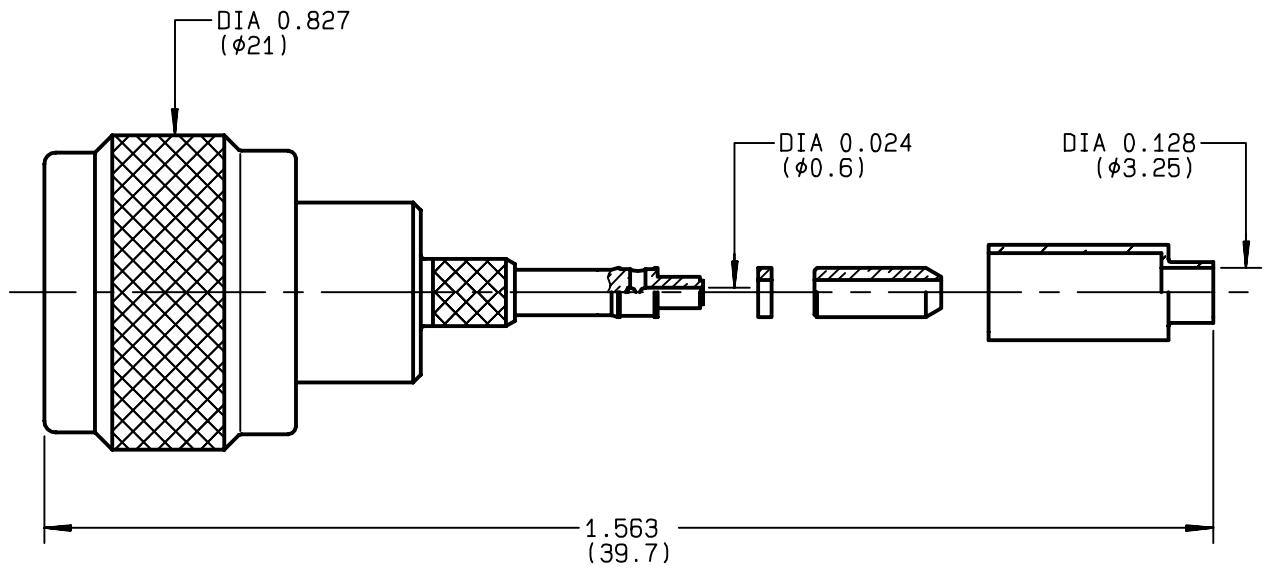

NOMINAL IMPEDANCE	50 Ω	CABLES : K02252D KX 22A RD 316 RG 188 RG 316
FREQUENCY RANGE	0-11 GHz	
TEMPERATURE RATING	-55/+155 °C	
V.S.W.R	1.30 + x F(GHz)Maxi	
RF INSERTION LOSS	0.048 √F(GHz) dB Maxi	
VOLTAGE RATING	250 Veff Maxi	
DIELECTRIC WITHSTANDING VOLTAGE	750 Veff Mini	
INSULATION RESISTANCE	5000 MΩMini	
HERMETIC SEAL	NA Atm.cm ³ /s	
LEAKAGE (pressurized only)	NA	
MECHANICAL DURABILITY	500 Cycles	OTHERS CHARACTERISTICS
WEIGHT	29.3 gr	CABLE RETENTION 40 N Mini
SPECIFICATION		CENTER CONTACT RETENTION
		Axial force - mating end 68 N Mini
		Axial force - opposite end 68 N Mini
		Torque NA cm.N Mini
		RECOMMENDED TORQUES
		Mating 130 cm.N
		Panel nut NA cm.N
		Clamp nut NA cm.N

CONNECTOR PARTS	MATERIALS	FINISH	(all values are given in micrometers)
BODY	BRASS	BBR 2	
OUTER CONTACT	BRASS	BBR 2	
CENTER CONTACT	BRASS	GOLD 0.5 OVER NICKEL 2	
INSULATOR	PTFE	-	
GASKET	SILICONE RUBBER	-	
OTHERS PIECES	BRASS	BBR 2	

ISSUE 9812C01	CREATION DATE 21/07/1993	FILE PART-NUMBER EPC 96-07
-------------------------	------------------------------------	--------------------------------------



BONMINI

The information given here is subject to change without notice.
Design changes may be in order to improve the product .

Connect to the future



R161.072.000

ISSUE **9812C01** SERIES **N**

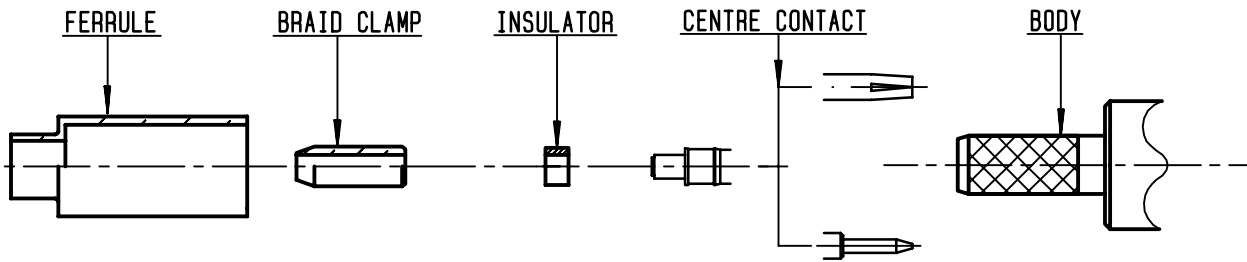

①

Slide onto the cable the ferrule
Strip the cable .

-
-

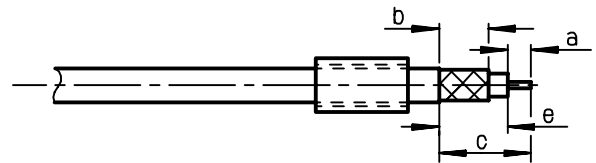

Stripping	a	b	c	d	e
inch	0.177	0.315	0.551	0	0.374
mm	4.5	8	14		9.5

②

Fan the braid .
Slide the braid clamp and insulator
between the dielectrique and the braid .
Slide on centre contact until it
bottoms against cable dielectrique .

Crimp centre contact .

Crimping tool : R282 223 000 (Hex. : 0.068)
or crimping tool R282 293 000 (M22520/5-01)
+ dies R282 235 011 (M22520/5-11)

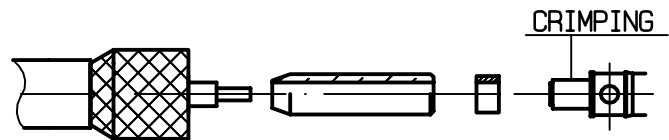

③

Slide cable dielectric into the body
while gently grinding the braid over the knurl
Push until the dielectric clicks into
position .
Slide ferrule over braid in direction F .

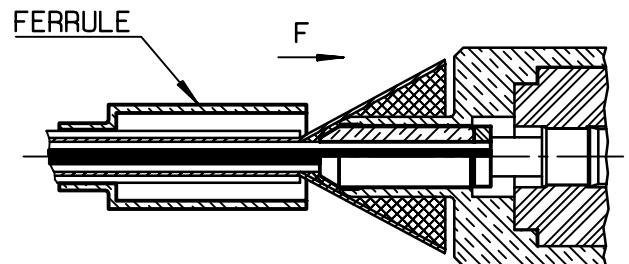

④

Crimp the ferrule with crimping tool
R 282 223 000 (Hex. : 0.213) or
crimping tool R282 293 000 (M22520/5-01)
+ dies R282 235 011 (M22520/5-11)
Cut the excess of braid .

-
-

