

## ISL62881CCPUEVAL2Z

Evaluation Board

AN1552  
Rev 0.00  
Mar 24, 2010

### Hardware Description

The ISL62881CCPUEVAL2Z evaluation board demonstrates the performance of the ISL62881C single-phase synchronous-buck PWM  $V_{CORE}$  controller implementing Intel IMVP-6.5 protocol. The ISL62881C features Intersil's Robust Ripple Regulator ( $R^3$ ) technology. An on-board dynamic-load generator is included for evaluating the transient-load response. It applies a 300 $\mu$ s pulse of approximately 0.2 $\Omega$  load across  $V_O$  and PGND.

Contents of this document include:

- Design Criteria
- Recommended Test Equipment
- Interface Connections
- Switch Descriptions
- DIP Switch Descriptions
- Jumper Descriptions
- Test Point Descriptions
- Evaluation Board Documentation
  - Bill of materials
  - Schematic
  - Silk-screen plots
  - Board layer plots

TABLE 1. DC/DC DESIGN CRITERIA

PARAMETER	VALUE	UNITS
$V_{IN}$	4.5 to 20	VDC
$V_O$	0 to 1.5	VDC
Full-load	26	ADC
PWM Frequency	300	kHz

### Recommended Equipment

- (Qty. 1) Adjustable 25V, 10A Power Supply
- (Qty. 1) Fixed 5V, 100mA Power Supply
- (Qty. 1) Fixed 12V, 100mA Power Supply
- (Qty. 1) Adjustable Constant Current Electronic Load
- (Qty. 1) Digital Voltmeter
- (Qty. 1) Four-Channel Oscilloscope

### Interface Connections

- $V_{IN}$ : Input Voltage to the Power Stage
  - J5:  $V_{IN}$  Positive Power Input
  - TP31:  $V_{IN}$  Positive Voltage Sense
  - J6:  $V_{IN}$  Return Power Input
  - TP32:  $V_{IN}$  Return Voltage Sense
- $V_O$ : Regulated Output Voltage
  - J12:  $V_O$  Positive Power Output
  - J14:  $V_O$  Return Power Output
- +5V: +5V Input Voltage
  - TP29: +5V Positive Input
  - TP30: +5V Return Input
- +12V: Input Voltage for the Dynamic-load Generator
  - TP3: 12V Positive Input
  - TP2: 12V Return Input

### Test Set-Up

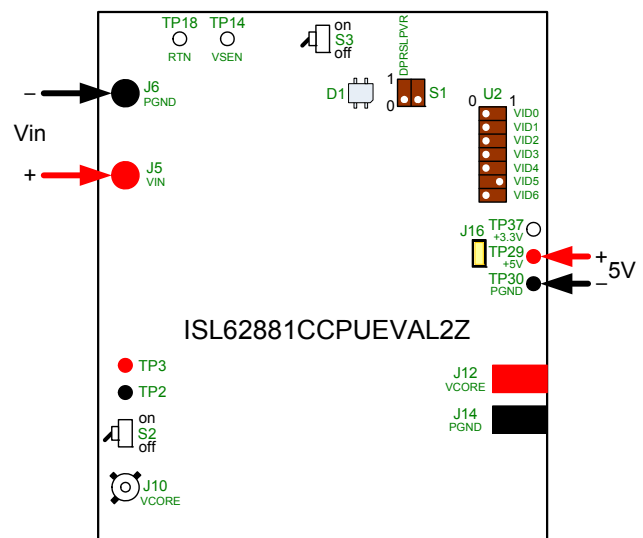

FIGURE 1. TEST SET-UP

### Switch Descriptions

- S3: Enable
  - OFF: Short the VR\_ON pin to GND (disable PWM)
  - ON: Allow the VR\_ON pin to pull-up to +5V (enable PWM)
- S2: Dynamic Load
  - OFF: On-board dynamic load disabled
  - ON: On-board dynamic load enabled

## DIP-Switch Descriptions

- S1: Set the control signals
  - S1.1: Set the DPRSLPVR signal
  - S1.2: Set the DPRSTP# signal
- U2: Set the VID

## Jumper Descriptions

- J16: If installed, the +5V rail supplies the +3.3V rail to the auxiliary circuit on the board. **DO NOT APPLY +3.3V TO TP37/ TP30 WHILE J16 IS INSTALLED! IT'LL SHORT THE +5V AND THE +3.3V POWER SUPPLIES.** When measuring board efficiency, uninstall J16 and apply +3.3V to TP37/TP30.

## Test Point Descriptions

TEST POINT	DESCRIPTION
J7	Scope-probe socket for measuring PHASE1.
J10	Scope-probe socket for measuring $V_O$ .
J15	Scope-probe socket for measuring the current of the on-board transient-load emulator.
TP1	Monitor the on-board 1.2V power supply.
TP2	+ 12V power supply return input.
TP3	+ 12V power supply positive input.
TP4	Monitor the COMP pin.
TP5	Monitor the VW pin.
TP6	Monitor the FB pin.
TP7	Monitor the DPRSLPVR pin.

## Test Point Descriptions (Continued)

TEST POINT	DESCRIPTION
TP12	Input side of the compensator.
TP13	Monitor the PGOOD pin.
TP14	Monitor the VSEN pin.
TP16	Monitor the CLK_EN# pin.
TP17	Monitor the VR_ON pin.
TP18	Monitor the RTN pin.
TP19	Monitor the positive side of C82.
TP20	Monitor the negative side of C82.
TP21	Monitor the VID6 pin.
TP22	Monitor the VID5 pin.
TP23	Monitor the VID4 pin.
TP24	Monitor the VID3 pin.
TP25	Monitor the VID2 pin.
TP26	Monitor the VID1 pin.
TP27	Monitor the VID0 pin.
TP28	Monitor the IMON pin.
TP29	+ 5V power supply positive input.
TP30	+ 5V power supply return input.
TP31	$V_{IN}$ positive voltage sense.
TP32	$V_{IN}$ return voltage sense.
TP33	Monitor MOSFET Q3 gate signal.
TP37	+ 3.3V power supply positive input.

## Bill of Materials

QTY	REFERENCE	VALUE	DESCRIPTION	MFG.	PART NUMBER	PACKAGE
1	PCB		ISL62881CPUEVAL2ZREVD			
1	C1	0.01 $\mu$ F	Multilayer Cap, 16V, 10%	GENERIC	H1045-00103-16V10	SM0603
1	C11	1000pF	Multilayer Cap, 16V, 10%	GENERIC	H1045-00102-16V10	SM0603
1	C12	330pF	Multilayer Cap, 16V, 10%	GENERIC	H1045-00331-16V10	SM0603
1	C13	1000pF	Multilayer Cap, 16V, 10%	GENERIC	H1045-00102-16V10	SM0603
0	C14, C15, C19, C39, C44, C81, C86	DNP				
5	C16, C2, C22, C23, C79	1 $\mu$ F	Multilayer Cap, 16V, 20%	GENERIC	H1045-00105-16V20	SM0603
3	C17, C18, C30	0.22 $\mu$ F	Multilayer Cap, 25V, 10%	GENERIC	H1045-00224-25V10	SM0603
3	C20, C45, C58	0.1 $\mu$ F	Multilayer Cap, 16V, 10%	GENERIC	H1045-00104-16V10	SM0603
1	C21	0.047 $\mu$ F	Multilayer Cap, 16V, 10%	GENERIC	H1045-00473-16V10	SM0603
1	C25	56 $\mu$ F	Radial SP Series Cap, 25V, 20%	SANYO	25SP56M	CASE-CC

## Bill of Materials (Continued)

QTY	REFERENCE	VALUE	DESCRIPTION	MFG.	PART NUMBER	PACKAGE
3	C27, C33, C80	10 $\mu$ F	Multilayer Cap, 25V, 20%	GENERIC	H1065-00106-25V20	SM1206
1	C3	390pF	Multilayer Cap, 16V, 10%	GENERIC	H1045-00391-16V10	SM0603
2	C52, C57	330 $\mu$ F	SPCAP, 2V, 4MW	PANASONIC	EESX0D331E4	
1	C4	1000pF	Multilayer Cap, 16V, 10%	GENERIC	H1045-00102-16V10	SM0603
30	C40-C43, C47-C50, C53-C56, C59, C75, C78	10 $\mu$ F	Multilayer Cap, 6.3V, 20%	TAIYO	JMK212BJ106MG-T	SM0805
				MURATA	GRM21BR60J106ME19	
				Kyocera	CM21X5R106M06AT	
				TDK	C2012X5R0J106MT009N	
1	C6	56pF	Multilayer Cap, 16V, 10%	GENERIC	H1045-00563-16V10	SM0603
1	C82	0.047 $\mu$ F	Multilayer Cap, 16V, 10%	GENERIC	H1045-00820-16V10	SM0603
1	D1		3mmx2.5mm Surface Mount Red/Green LED	Lumex	SSL-LXA3025IGC	LED_3x2_5MM
1	J10		Scope Probe Test Point PCB Mount	TEKTRONIX	131-4353-00	TEK131-4353-00
0	J15, J7	DNP				
2	J12, J14		Wire Connector Lug	BURNDY	KPA8CTP	KPA8CTP
1	J16		2 Pin Header 2.54mm (0.100) Pitch	BERG?FCI	69190-202	CONN2
1	J5		Binding Post Red	JOHNSON- COMP	111-0702-001	111-07XX-001
1	J6		Binding Post Black	JOHNSON- COMP	111-0703-001	111-07XX-001
1	L1	0.45 $\mu$ H	Inductor, Inductance 20%, DCR 7%	NEC-TOKIN	MPCG1040LR45	6.5mm x 6.5mm
2	Q1, Q14		N-Channel EMF Effect Transistor (Pb-Free)	FAIRCHILD	2N7002-7-F	SOT23
1	Q15		N-Channel 30V (D-S) MOSFET	VISHAY	SUD50N03-07	TO-252AA
2	Q2, Q8		N-Channel Power MOSFET	IR	IRF7821	PWRPAKSO8
2	Q3, Q9		N-Channel Power MOSFET	IR	IRF7832	PWRPAKSO8
1	R1	49.9	Thick Film Chip Resistor, 1%	GENERIC	H2511-049R9-1/16W1	SM0603
1	R10	715	Thick Film Chip Resistor, 1%	GENERIC	H2511-07150-1/16W1	SM0603
1	R102	49.9k	Thick Film Chip Resistor, 1%	GENERIC	H2511-04992-1/16W1	SM0603
2	R104, R105	249	Thick Film Chip Resistor, 1%	GENERIC	H2511-02490-1/16W1	SM0603
1	R106	0.2	Thick Film Chip Resistor, 1%	GENERIC	H2515-00R20-1W1-T	SM2512
0	R109, R110, R111, R113, R114, R121, R2, R26, R31, R4, R44, R68, R77, R93, R99, R107, R117	DNP				
1	R11	1.33k	Thick Film Chip Resistor, 1%	GENERIC	H2511-01331-1/16W1	SM0603
3	R13, R15, R103	499	Thick Film Chip Resistor, 1%	GENERIC	H2511-04990-1/16W1	SM0603
1	R115	0	Thick Film Chip Resistor, 1%	GENERIC	H2511-00R00-1/16W1	SM0603
1	R16	147k	Thick Film Chip Resistor, 1%	GENERIC	H2511-01473-1/16W1	SM0603

## Bill of Materials (Continued)

QTY	REFERENCE	VALUE	DESCRIPTION	MFG.	PART NUMBER	PACKAGE
2	R17, R18	10	Thick Film Chip Resistor, 1%	GENERIC	H2511-00100-1/16W1	SM0603
2	R19, R23	1.91k	Thick Film Chip Resistor, 1%	GENERIC	H2511-01911-1/16W1	SM0603
17	R20, R22, R24, R25, R27, R29, R32, R33, R34, R35, R40, R52, R56, R62, R87, R112, R116	0	Thick Film Chip Resistor, 1%	GENERIC	H2511-00R00-1/16W1	SM0603
9	R21, R28, R36, R39, R43, R45, R46, R49, R51	10k	Thick Film Chip Resistor, 1%	GENERIC	H2511-01002-1/16W1	SM0603
1	R30	909	Thick Film Chip Resistor, 1%	GENERIC	H2511-09090-1/16W1	SM0603
1	R37	1	Thick Film Chip Resistor, 1%	GENERIC	H2511-01R00-1/16W1	SM0603
1	R38	11k	Thick Film Chip Resistor, 1%	GENERIC	H2511-01102-1/16W1	SM0603
1	R41	2.61k	Thick Film Chip Resistor, 1%	GENERIC	H2511-02611-1/16W1	SM0603
1	R42	10k NTC	Thermistor, 10k NTC	PANASONIC	ERT-J1VR103J	SM0603
2	R5, R80	100	Thick Film Chip Resistor, 1%	GENERIC	H2511-01000-1/16W1	SM0603
1	R50	7.68k	Thick Film Chip Resistor, 1%	GENERIC	H2511-07681-1/16W1	SM0603
2	R59, R96	0	Solder Joint (Heavy Duty)			
1	R6	9.09k	Thick Film Chip Resistor, 1%	GENERIC	H2511-09091-1/16W1	SM0603
1	R63	1.82k	Thick Film Chip Resistor, 1%	GENERIC	H2511-01821-1/16W1	SM0805
1	R7	226k	Thick Film Chip Resistor, 1%	GENERIC	H2511-02263-1/16W1	SM0603
1	S1		SD Series Low Profile Dip Switch	C&K	SD02H0SK	DIPSWMT-4
2	S2, S3		SPDT On-None-On SMT Ultraminiature Toggle Switch	C&K	GT11MSCKE	GT13MSCKE
1	S4		Schottky Barrier (Double) Diode	DIODES	BAT54S	SOT23
4	TP2, TP3, TP29, TP30		Test Point Turret 0.15 Pad 0.1 Thole	KEYSTONE	1514-2	TP-150C100P
28	TP1, TP4-TP7, TP12-TP14, TP16-TP28, TP31-TP33, TP37, TP40		Miniature White Test Point 0.100 Pad 0.040 Thole	KEYSTONE	5002	MTP500X
0	TP38, TP39, TP9	DNP				
1	U1		Low Volt Precision Adjustable Shunt Regulator	ON-SEMI	TLV431ASNT1	TSOP-5
1	U2		SD Series Low Profile Dip Switch	C&K	SD07H0SK	DIPSWMT-14
1	U4		rPGA989 CPU Socket	FOXCONN		
1	U5		100V/2A Peak High Frequency Half Bridge Driver (Pb-Free)	INTERSIL	HIP2100IBZ	SOIC8_150_50
1	U6		IMVP-6 PWM Controller	INTERSIL	ISL62881CHRTZ	QFN-28

# ISL62881CCPUEVAL2Z Schematics

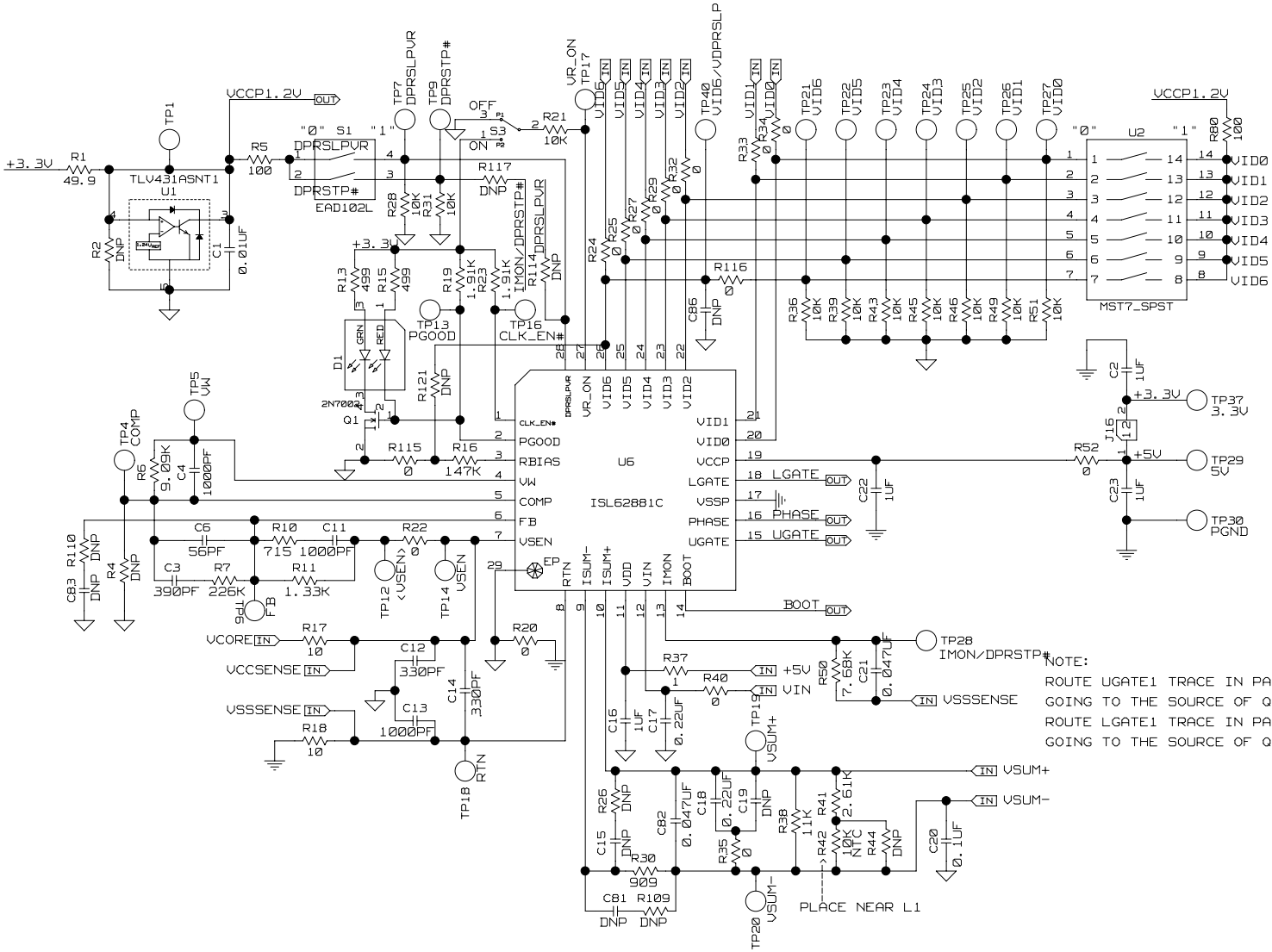

FIGURE 2. ISL62881CCPUEVAL2Z SCHEMATIC, 1 OF 5

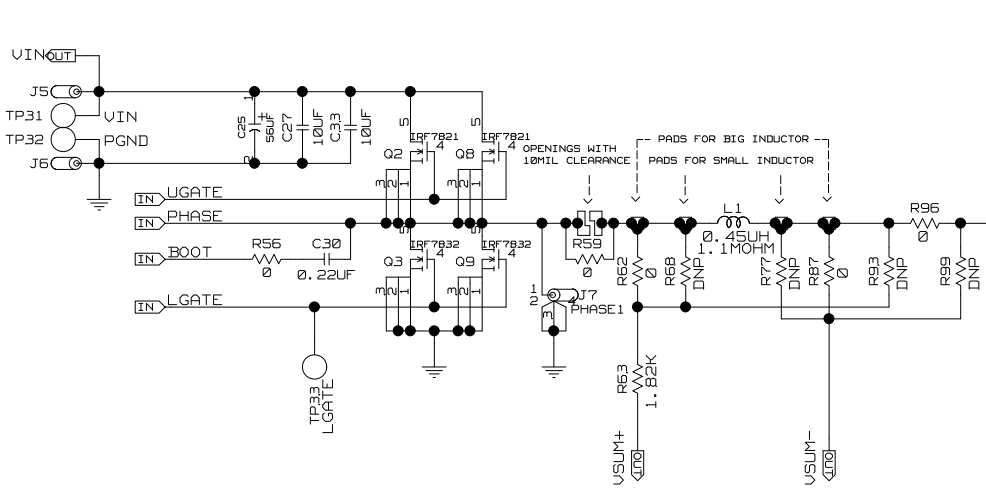
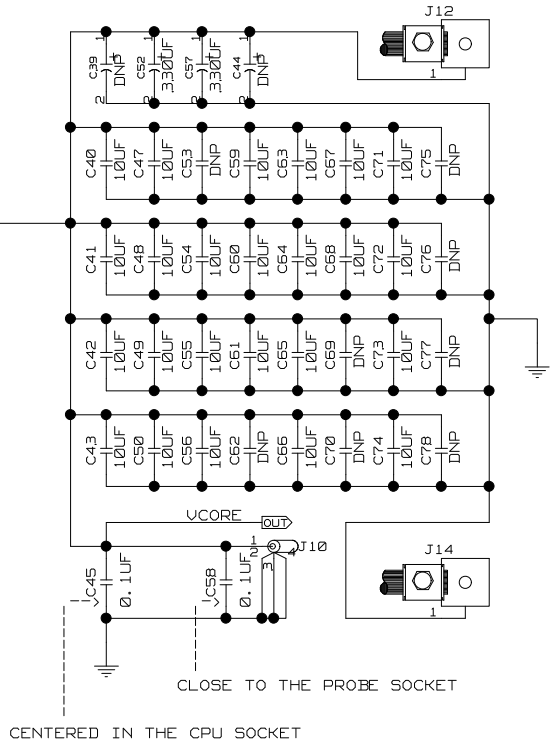

FIGURE 3. ISL62881CCPUEVAL2Z SCHEMATIC, 2 OF 5

ISL62881CCPUEVAL2Z Schematics (Continued)

# ISL62881CCPUEVAL2Z Schematics (Continued)

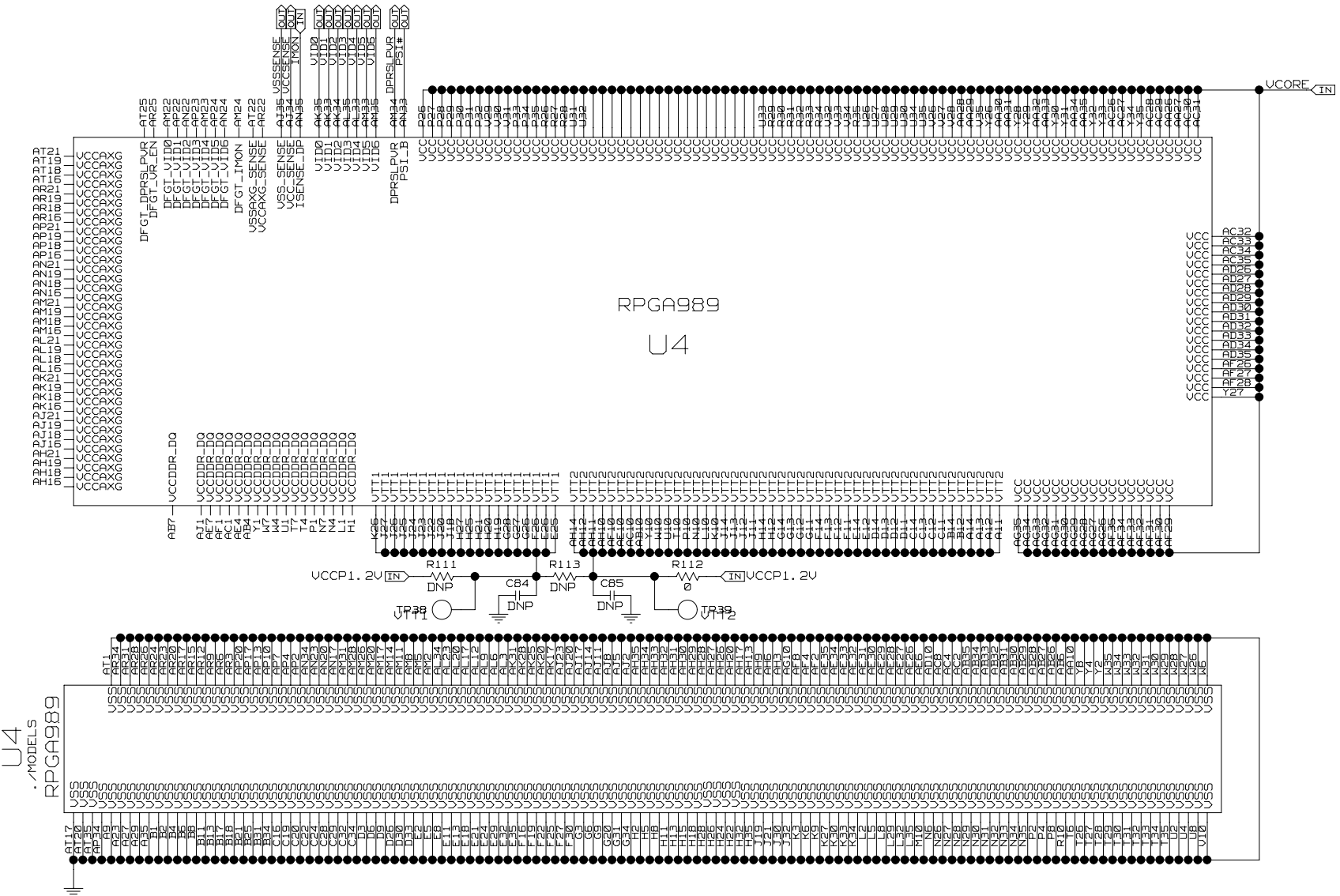

FIGURE 4. ISL62881CCPUEVAL2Z SCHEMATIC, 3 OF 5

ISL62881CCPUEVAL2Z Schematics (Continued)

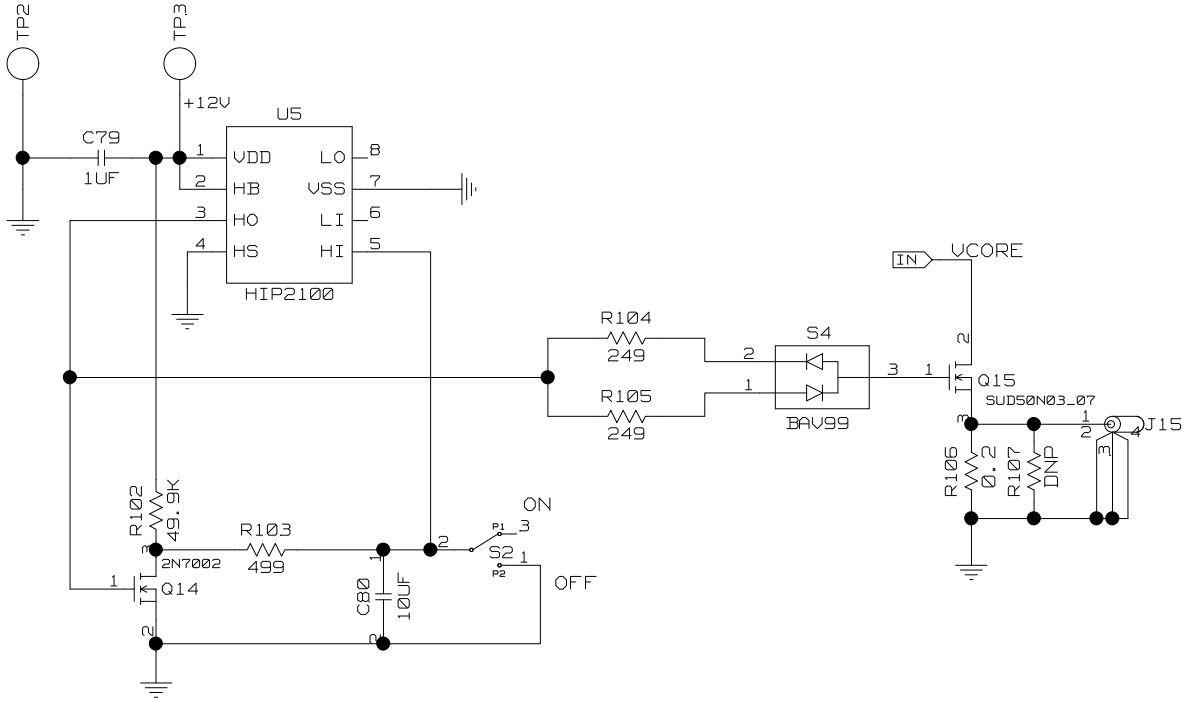

FIGURE 5. ISL62881CCPUEVAL2Z SCHEMATIC, 4 OF 5



# ISL62881CCPUEVAL2Z Schematics (Continued)

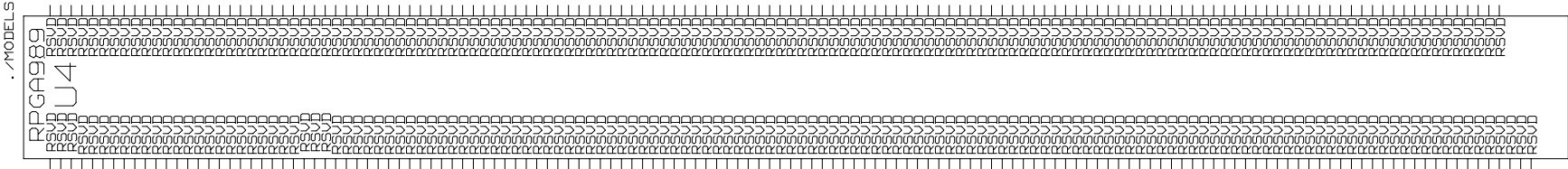
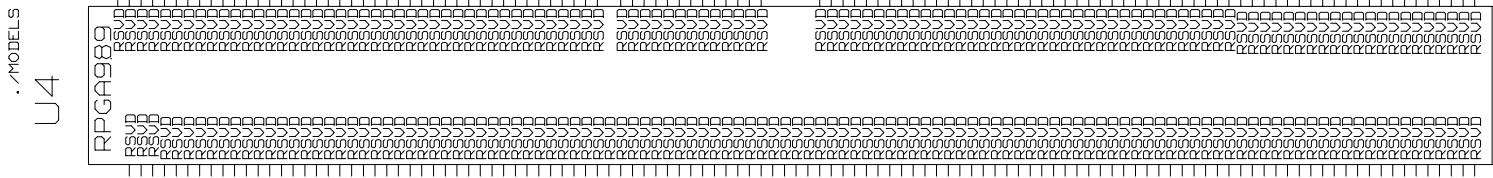

FIGURE 6. ISL62881CCPUEVAL2Z SCHEMATIC, 5 OF 5

# ISL62881CCPUEVAL2Z Evaluation Board Layout

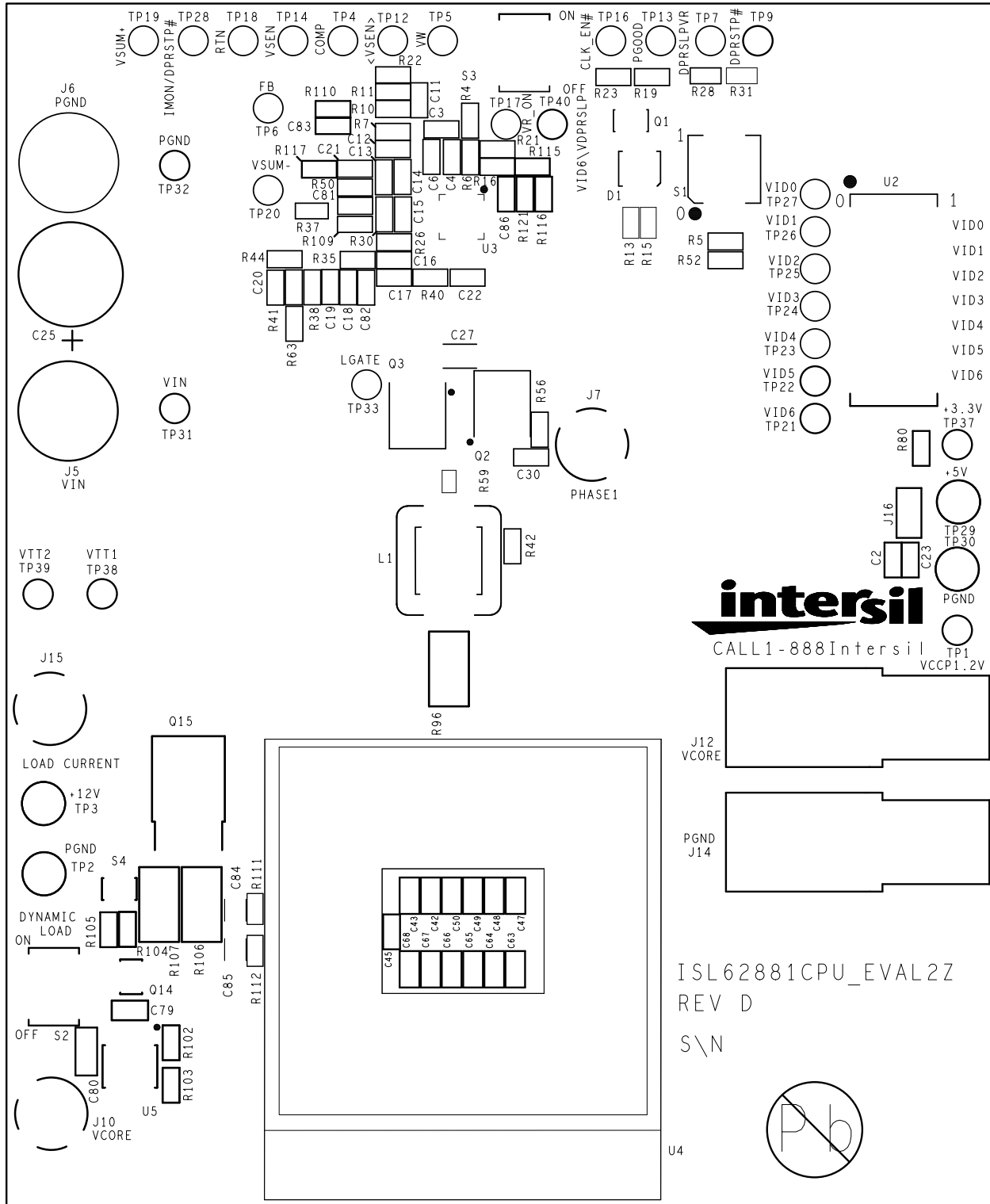

FIGURE 7. TOP SILKSCREEN

ISL62881CCPUEVAL2Z Evaluation Board Layout (Continued)

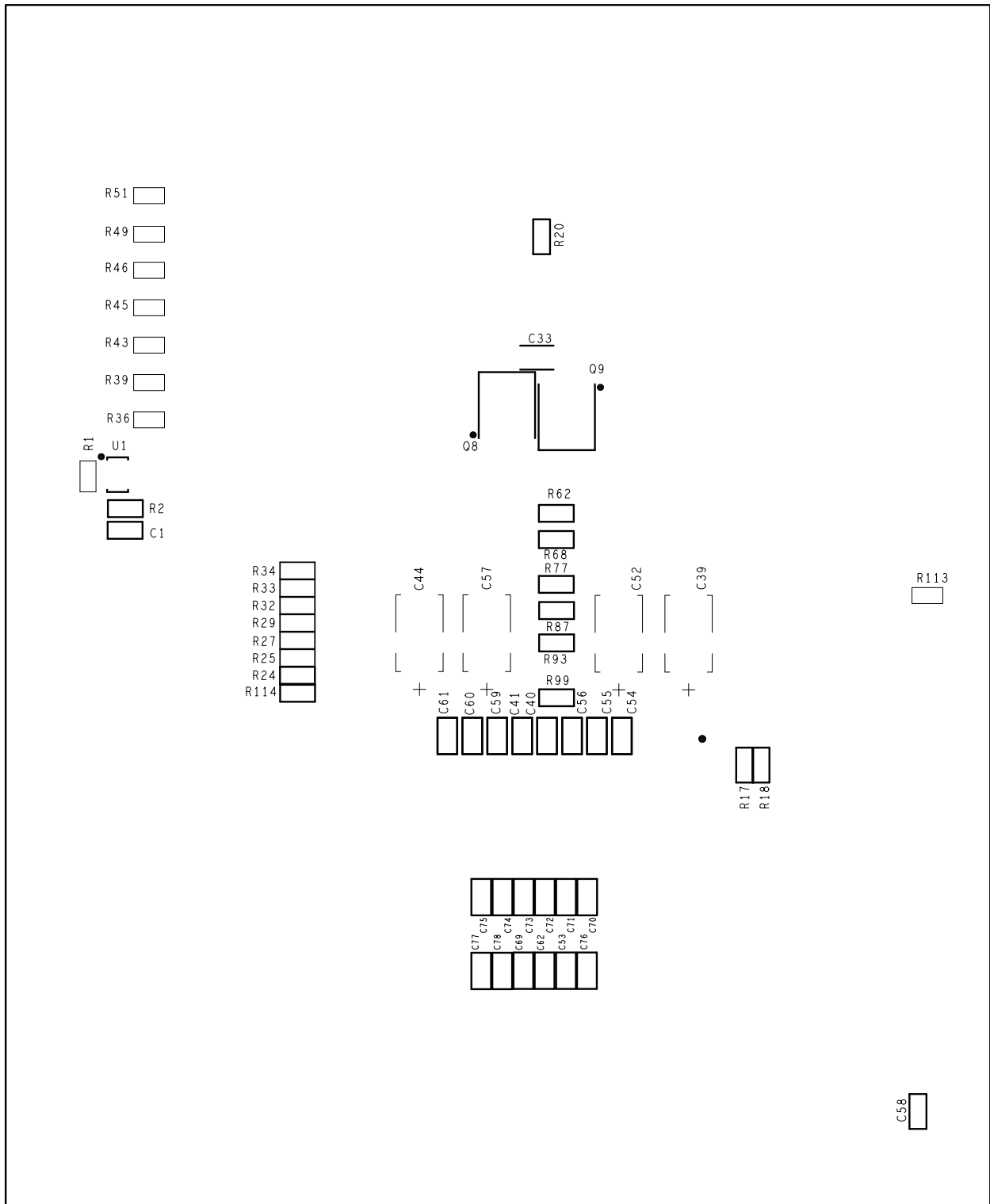

FIGURE 8. BOTTOM SILKSCREEN

# ISL62881CCPUEVAL2Z Evaluation Board Layout (Continued)

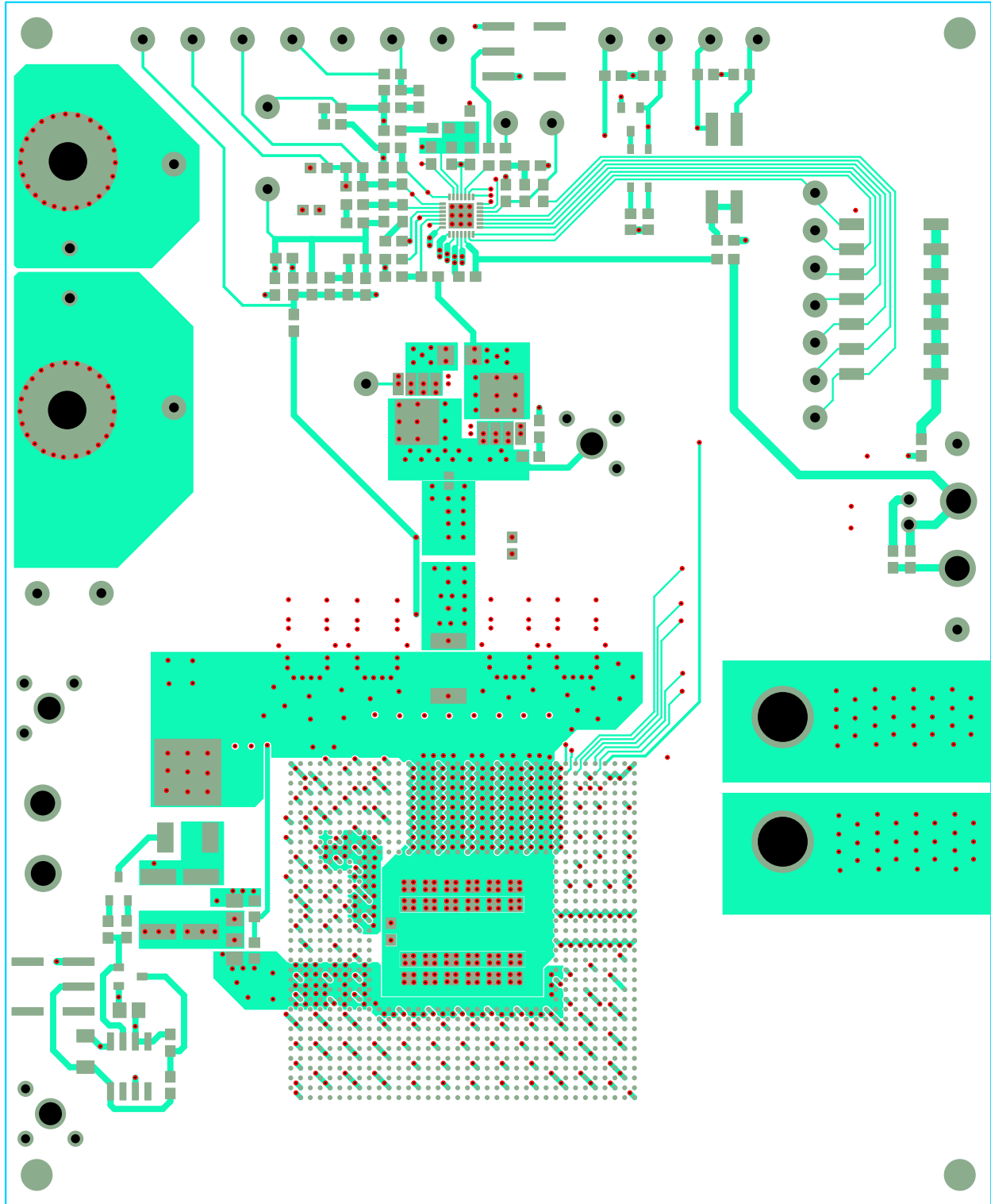

FIGURE 9. LAYER 1

ISL62881CCPUEVAL2Z Evaluation Board Layout (Continued)

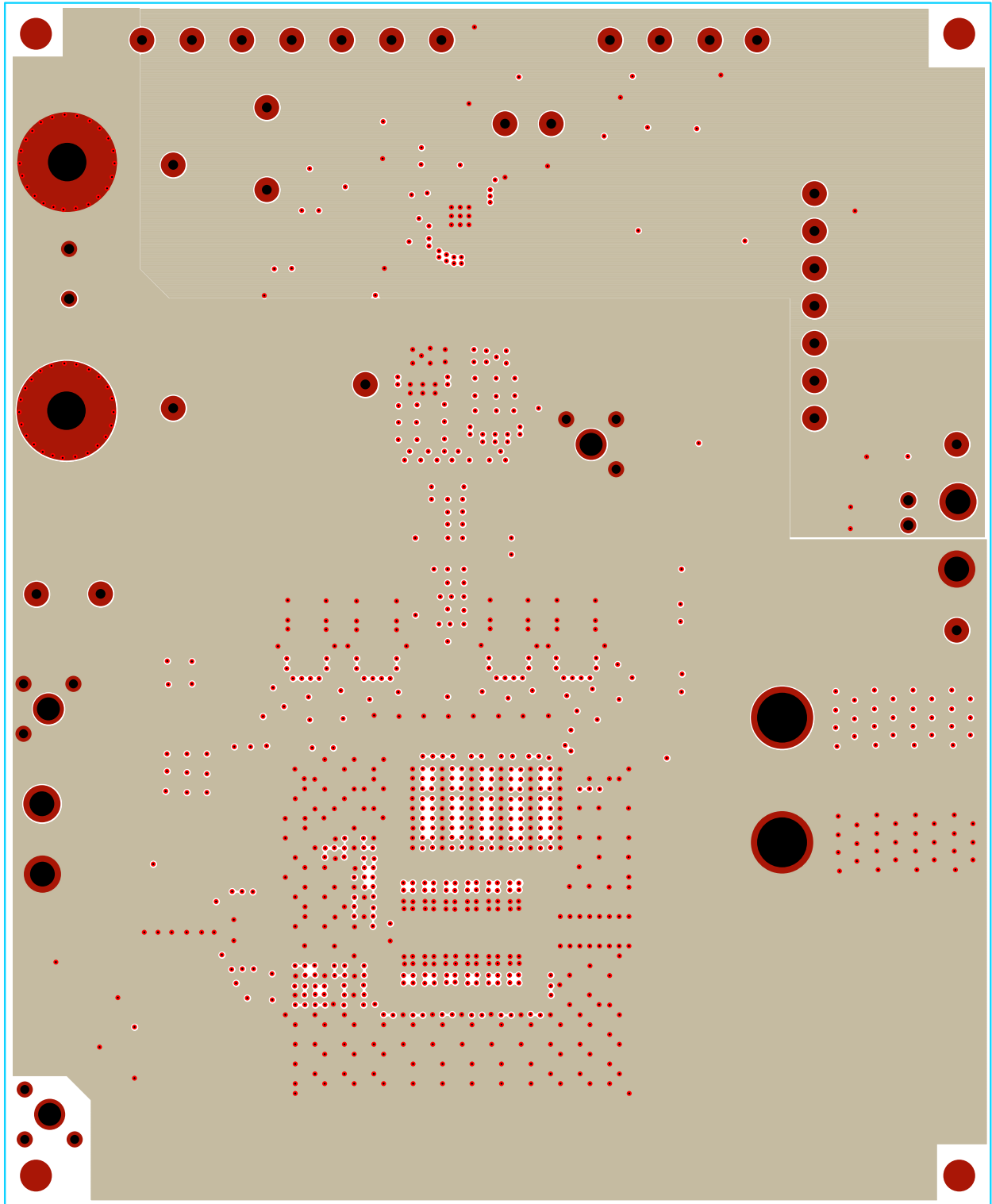

FIGURE 10. LAYER 2

ISL62881CCPUEVAL2Z Evaluation Board Layout (Continued)

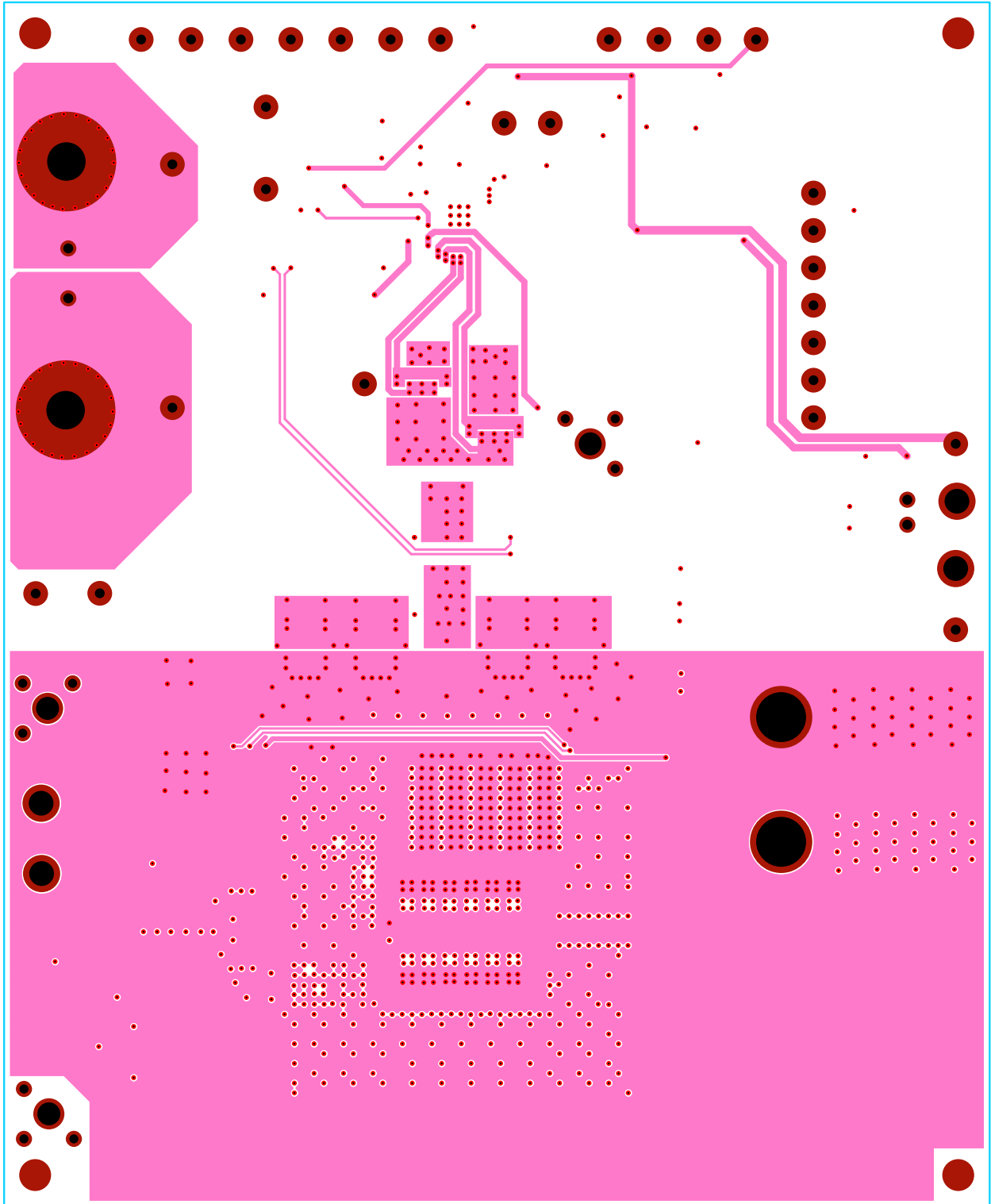

FIGURE 11. LAYER 3

ISL62881CCPUEVAL2Z Evaluation Board Layout (Continued)

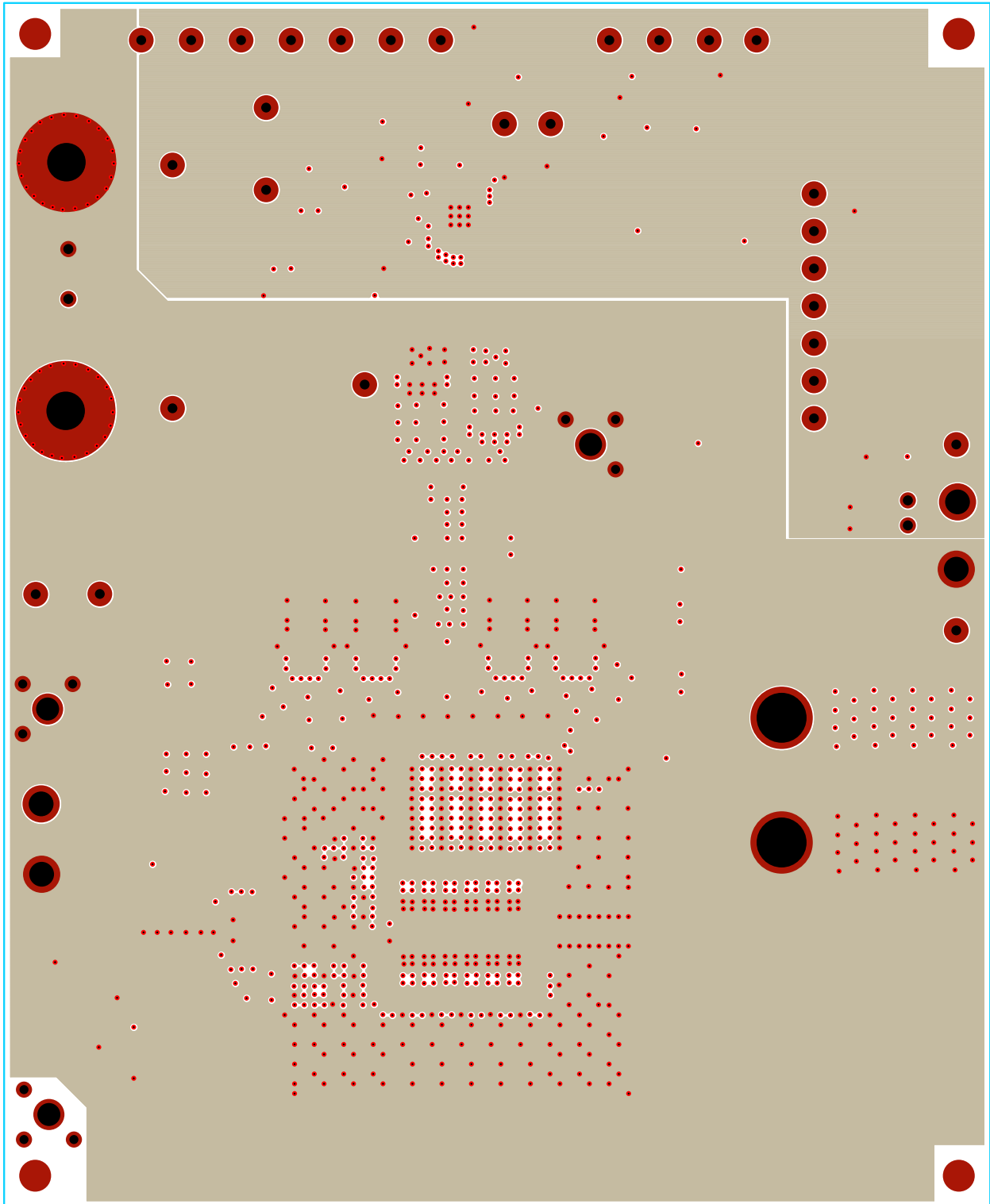

FIGURE 12. LAYER 4

ISL62881CCPUEVAL2Z Evaluation Board Layout (Continued)

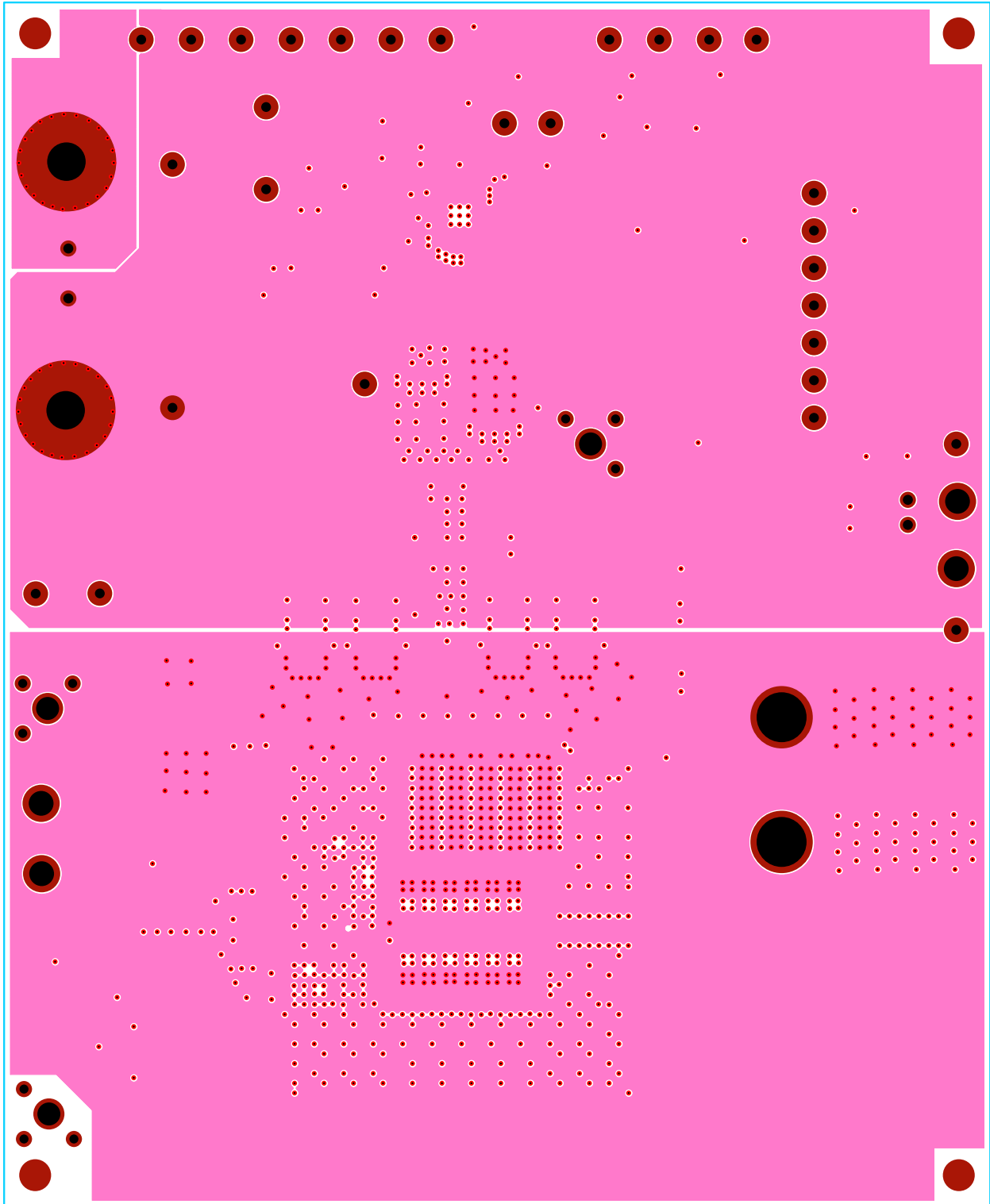

FIGURE 13. LAYER 5



ISL62881CCPUEVAL2Z Evaluation Board Layout (Continued)

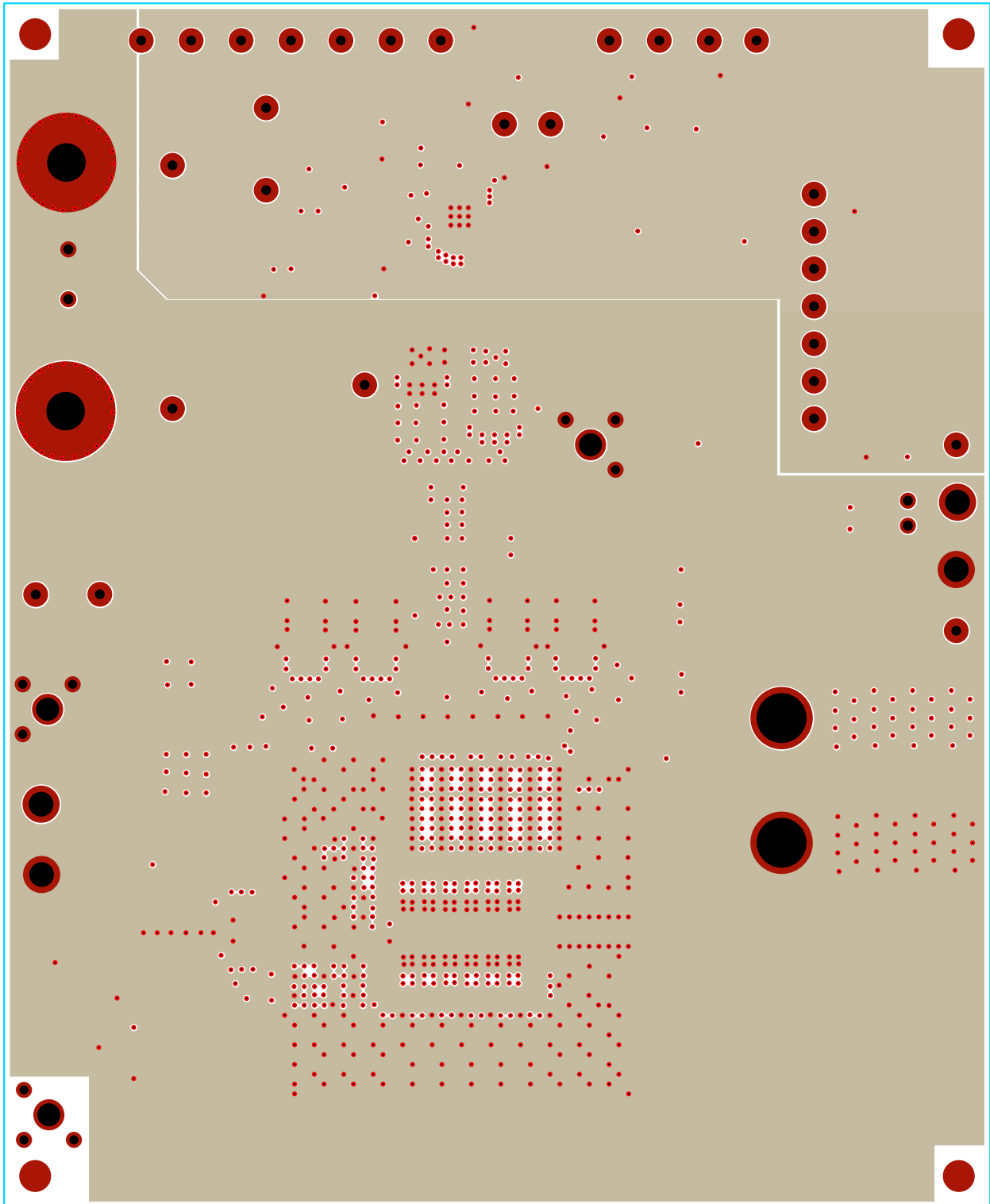

FIGURE 14. LAYER 6

ISL62881CCPUEVAL2Z Evaluation Board Layout (Continued)

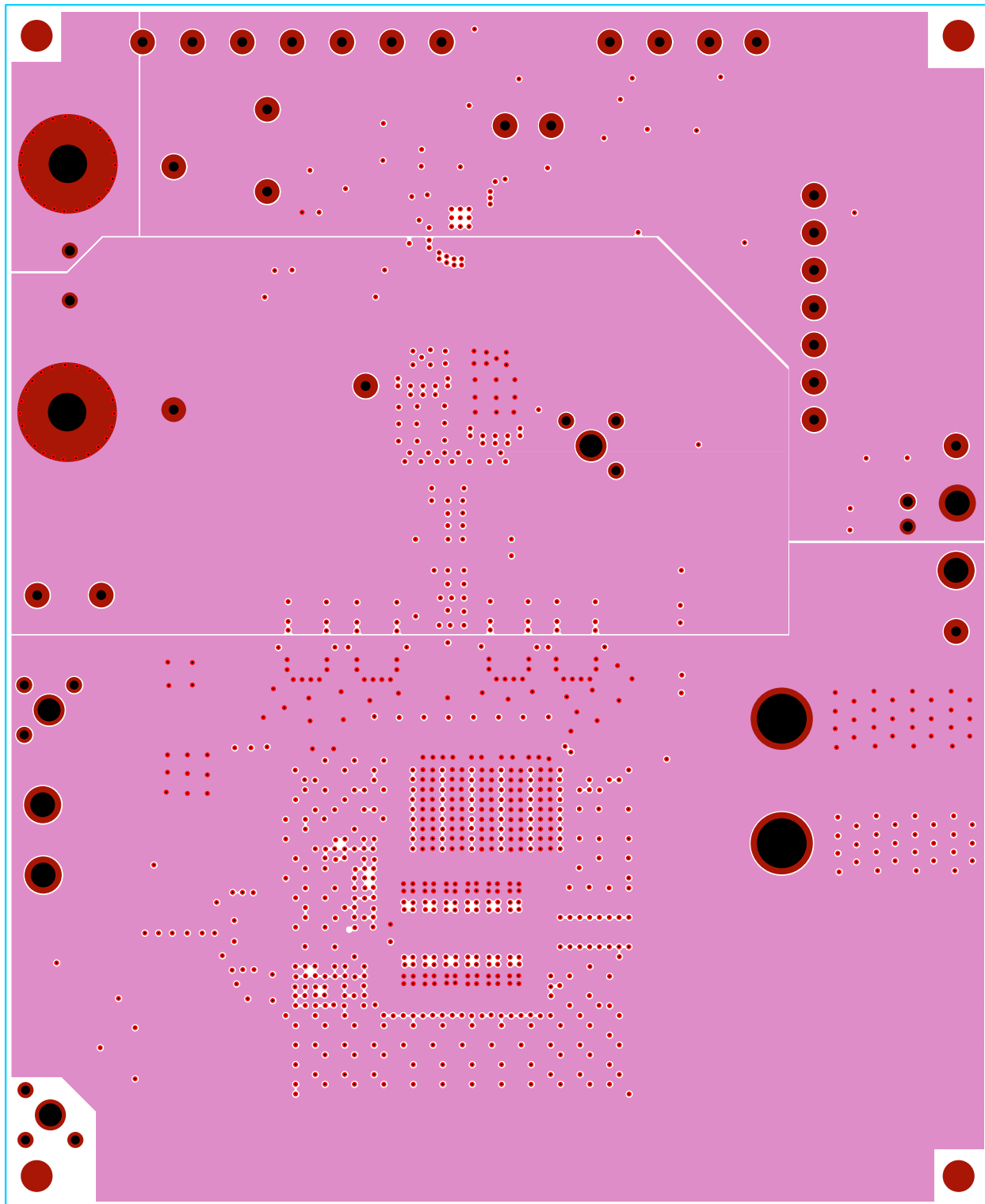

FIGURE 15. LAYER 7

# ISL62881CCPUEVAL2Z Evaluation Board Layout (Continued)

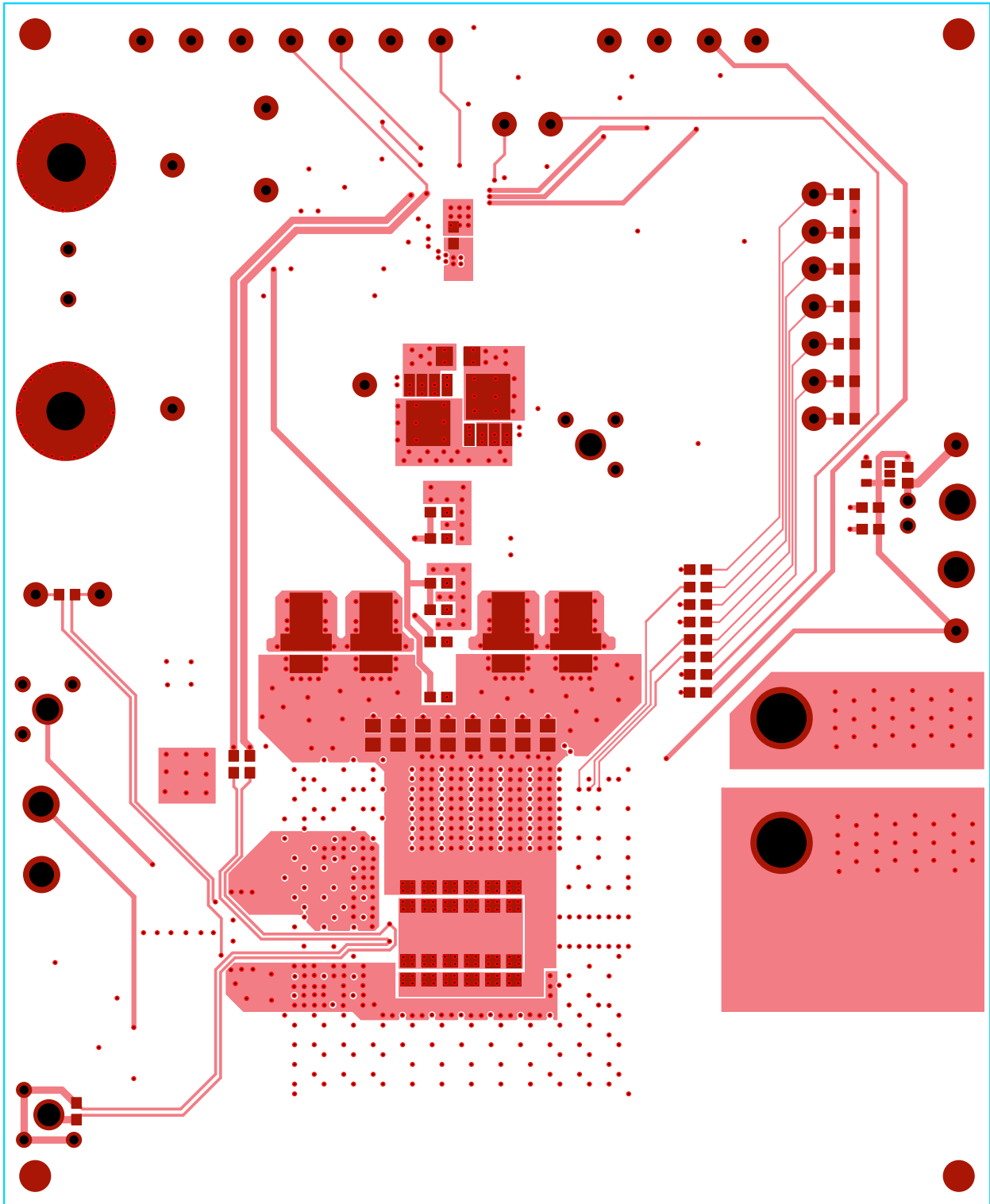

FIGURE 16. LAYER 8

## Notice

1. Descriptions of circuits, software and other related information in this document are provided only to illustrate the operation of semiconductor products and application examples. You are fully responsible for the incorporation or any other use of the circuits, software, and information in the design of your product or system. Renesas Electronics disclaims any and all liability for any losses and damages incurred by you or third parties arising from the use of these circuits, software, or information.
2. Renesas Electronics hereby expressly disclaims any warranties against and liability for infringement or any other claims involving patents, copyrights, or other intellectual property rights of third parties, by or arising from the use of Renesas Electronics products or technical information described in this document, including but not limited to, the product data, drawings, charts, programs, algorithms, and application examples.
3. No license, express, implied or otherwise, is granted hereby under any patents, copyrights or other intellectual property rights of Renesas Electronics or others.
4. You shall not alter, modify, copy, or reverse engineer any Renesas Electronics product, whether in whole or in part. Renesas Electronics disclaims any and all liability for any losses or damages incurred by you or third parties arising from such alteration, modification, copying or reverse engineering.
5. Renesas Electronics products are classified according to the following two quality grades: "Standard" and "High Quality". The intended applications for each Renesas Electronics product depends on the product's quality grade, as indicated below.  
"Standard": Computers; office equipment; communications equipment; test and measurement equipment; audio and visual equipment; home electronic appliances; machine tools; personal electronic equipment; industrial robots; etc.  
"High Quality": Transportation equipment (automobiles, trains, ships, etc.); traffic control (traffic lights); large-scale communication equipment; key financial terminal systems; safety control equipment; etc.  
Unless expressly designated as a high reliability product or a product for harsh environments in a Renesas Electronics data sheet or other Renesas Electronics document, Renesas Electronics products are not intended or authorized for use in products or systems that may pose a direct threat to human life or bodily injury (artificial life support devices or systems; surgical implantations; etc.), or may cause serious property damage (space system; undersea repeaters; nuclear power control systems; aircraft control systems; key plant systems; military equipment; etc.). Renesas Electronics disclaims any and all liability for any damages or losses incurred by you or any third parties arising from the use of any Renesas Electronics product that is inconsistent with any Renesas Electronics data sheet, user's manual or other Renesas Electronics document.
6. When using Renesas Electronics products, refer to the latest product information (data sheets, user's manuals, application notes, "General Notes for Handling and Using Semiconductor Devices" in the reliability handbook, etc.), and ensure that usage conditions are within the ranges specified by Renesas Electronics with respect to maximum ratings, operating power supply voltage range, heat dissipation characteristics, installation, etc. Renesas Electronics disclaims any and all liability for any malfunctions, failure or accident arising out of the use of Renesas Electronics products outside of such specified ranges.
7. Although Renesas Electronics endeavors to improve the quality and reliability of Renesas Electronics products, semiconductor products have specific characteristics, such as the occurrence of failure at a certain rate and malfunctions under certain use conditions. Unless designated as a high reliability product or a product for harsh environments in a Renesas Electronics data sheet or other Renesas Electronics document, Renesas Electronics products are not subject to radiation resistance design. You are responsible for implementing safety measures to guard against the possibility of bodily injury, injury or damage caused by fire, and/or danger to the public in the event of a failure or malfunction of Renesas Electronics products, such as safety design for hardware and software, including but not limited to redundancy, fire control and malfunction prevention, appropriate treatment for aging degradation or any other appropriate measures. Because the evaluation of microcomputer software alone is very difficult and impractical, you are responsible for evaluating the safety of the final products or systems manufactured by you.
8. Please contact a Renesas Electronics sales office for details as to environmental matters such as the environmental compatibility of each Renesas Electronics product. You are responsible for carefully and sufficiently investigating applicable laws and regulations that regulate the inclusion or use of controlled substances, including without limitation, the EU RoHS Directive, and using Renesas Electronics products in compliance with all these applicable laws and regulations. Renesas Electronics disclaims any and all liability for damages or losses occurring as a result of your noncompliance with applicable laws and regulations.
9. Renesas Electronics products and technologies shall not be used for or incorporated into any products or systems whose manufacture, use, or sale is prohibited under any applicable domestic or foreign laws or regulations. You shall comply with any applicable export control laws and regulations promulgated and administered by the governments of any countries asserting jurisdiction over the parties or transactions.
10. It is the responsibility of the buyer or distributor of Renesas Electronics products, or any other party who distributes, disposes of, or otherwise sells or transfers the product to a third party, to notify such third party in advance of the contents and conditions set forth in this document.
11. This document shall not be reprinted, reproduced or duplicated in any form, in whole or in part, without prior written consent of Renesas Electronics.
12. Please contact a Renesas Electronics sales office if you have any questions regarding the information contained in this document or Renesas Electronics products.  
(Note 1) "Renesas Electronics" as used in this document means Renesas Electronics Corporation and also includes its directly or indirectly controlled subsidiaries.  
(Note 2) "Renesas Electronics product(s)" means any product developed or manufactured by or for Renesas Electronics.

(Rev.4.0-1 November 2017)



### SALES OFFICES

Renesas Electronics Corporation

<http://www.renesas.com>

Refer to "<http://www.renesas.com/>" for the latest and detailed information.

#### Renesas Electronics America Inc.

1001 Murphy Ranch Road, Milpitas, CA 95035, U.S.A.  
Tel: +1-408-432-8888, Fax: +1-408-434-5351

#### Renesas Electronics Canada Limited

9251 Yonge Street, Suite 8309 Richmond Hill, Ontario Canada L4C 9T3  
Tel: +1-905-237-2004

#### Renesas Electronics Europe Limited

Dukes Meadow, Millboard Road, Bourne End, Buckinghamshire, SL8 5FH, U.K  
Tel: +44-1628-651-700, Fax: +44-1628-651-804

#### Renesas Electronics Europe GmbH

Arcadiastrasse 10, 40472 Düsseldorf, Germany  
Tel: +49-211-6503-0, Fax: +49-211-6503-1327

#### Renesas Electronics (China) Co., Ltd.

Room 1709 Quantum Plaza, No.27 ZhichunLu, Haidian District, Beijing, 100191 P. R. China  
Tel: +86-10-8235-1155, Fax: +86-10-8235-7679

#### Renesas Electronics (Shanghai) Co., Ltd.

Unit 301, Tower A, Central Towers, 555 Langao Road, Putuo District, Shanghai, 200333 P. R. China  
Tel: +86-21-2226-0888, Fax: +86-21-2226-0999

#### Renesas Electronics Hong Kong Limited

Unit 1601-1611, 16/F., Tower 2, Grand Century Place, 193 Prince Edward Road West, Mongkok, Kowloon, Hong Kong  
Tel: +852-2265-6688, Fax: +852 2886-9022

#### Renesas Electronics Taiwan Co., Ltd.

13F, No. 363, Fu Shing North Road, Taipei 10543, Taiwan  
Tel: +886-2-8175-9600, Fax: +886 2-8175-9670

#### Renesas Electronics Singapore Pte. Ltd.

80 Bendemeer Road, Unit #06-02 Hyflux Innovation Centre, Singapore 339949  
Tel: +65-6213-0200, Fax: +65-6213-0300

#### Renesas Electronics Malaysia Sdn.Bhd.

Unit 1207, Block B, Menara Amcorp, Amcorp Trade Centre, No. 18, Jln Persiaran Barat, 46050 Petaling Jaya, Selangor Darul Ehsan, Malaysia  
Tel: +60-3-7955-9390, Fax: +60-3-7955-9510

#### Renesas Electronics India Pvt. Ltd.

No.777C, 100 Feet Road, HAL 2nd Stage, Indiranagar, Bangalore 560 038, India  
Tel: +91-80-67208700, Fax: +91-80-67208777

#### Renesas Electronics Korea Co., Ltd.

17F, KAMCO Yangjae Tower, 262, Gangnam-daero, Gangnam-gu, Seoul, 06265 Korea  
Tel: +82-2-558-3737, Fax: +82-2-558-5338