

MATERIAL AND FINISHES:

SEE SHEETS 2 & 3 FOR PACKAGING INSTRUCTIONS)

SMP PLUG:
SEE SD-73415-428

SMP JACK:
SEE SD-73415-429

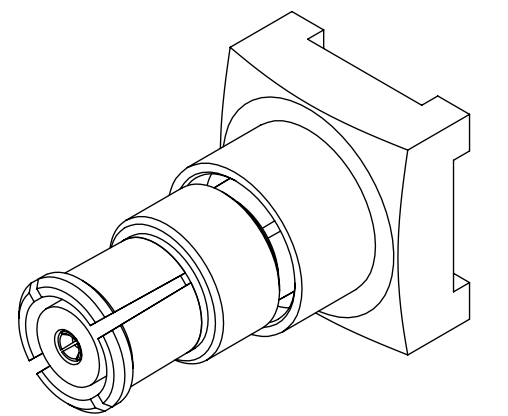
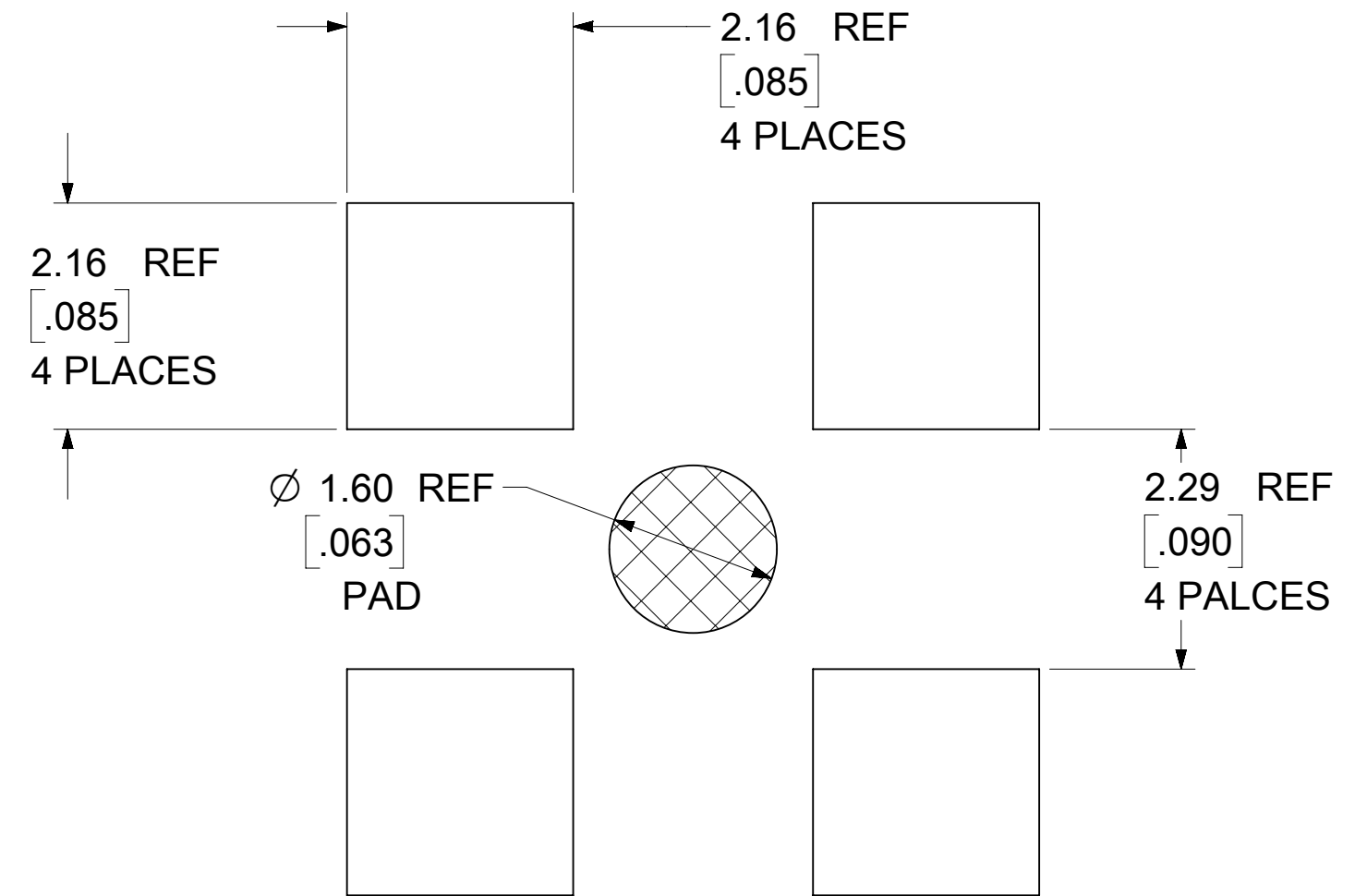
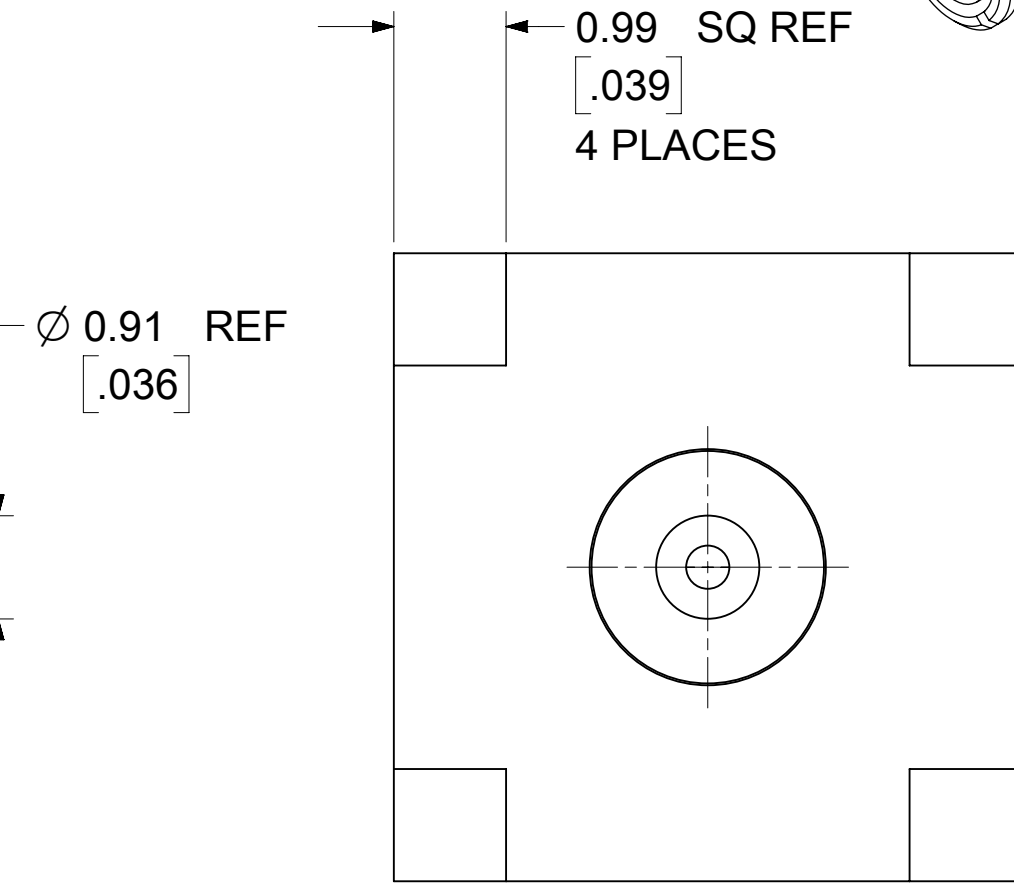
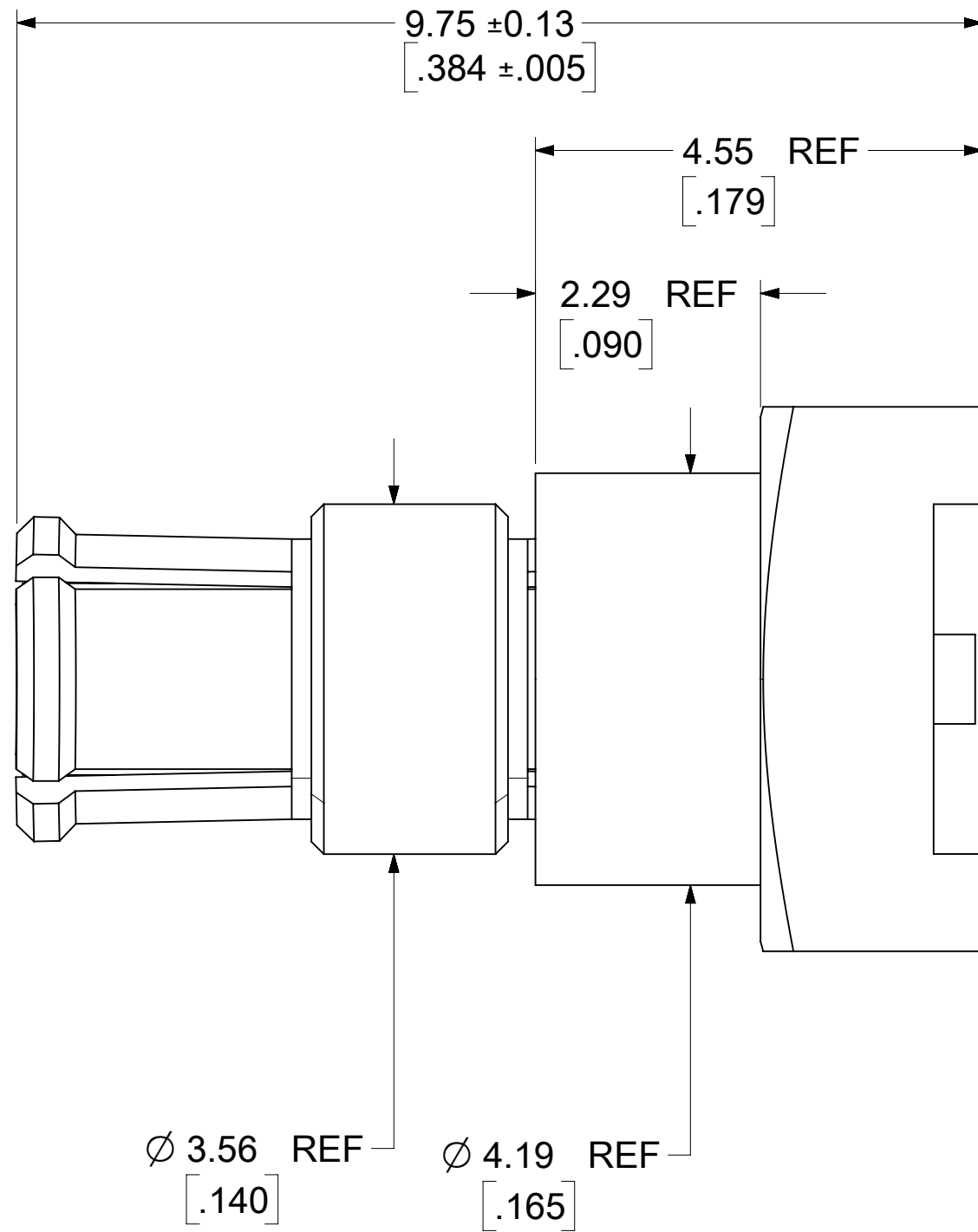
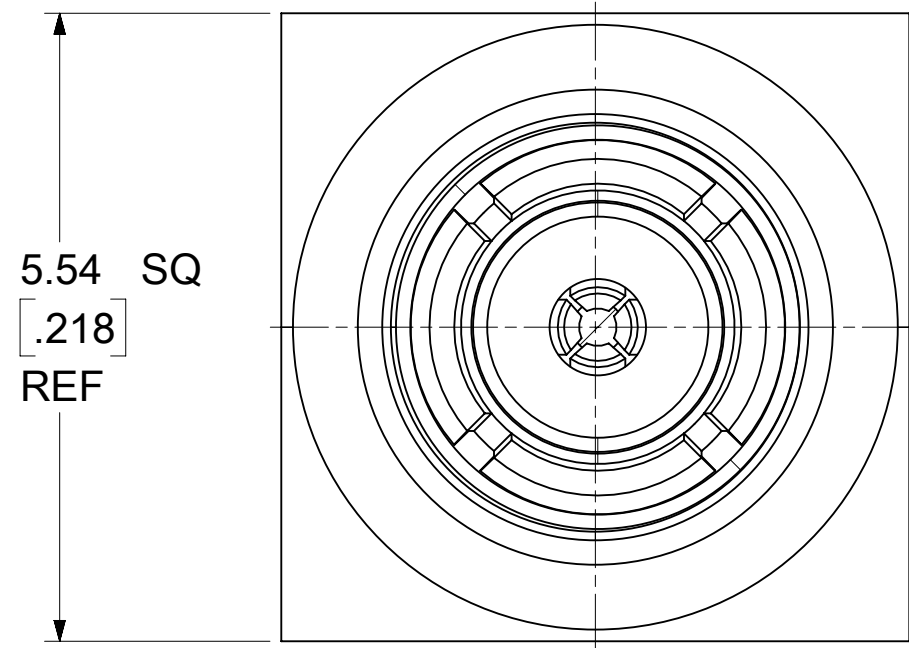

73415-4241	ONE PER BAG	895420470
73415-4240	TAPE & REEL	-----
PART NO.	PACKAGING	PACKING SPEC

PCB LAYOUT

FUNCTIONAL SYMBOLS	THIS DRAWING CONTAINS INFORMATION THAT IS PROPRIETARY TO MOLEX ELECTRONIC TECHNOLOGIES, LLC AND SHOULD NOT BE USED WITHOUT WRITTEN PERMISSION											
	DIMENSION UNITS	SCALE	CURRENT REV DESC:									
$\frac{F}{A} = 0$	MM/INCH	NTS	EWR # 15321-E ADDED -4241 PART NO									
GENERAL TOLERANCES (UNLESS SPECIFIED)	ANGULAR TOL ± 2.0°											
	4 PLACES	±	EC NO: 718007 DRWN: JSU18 2022/08/10 CHK'D: YCHENG 2022/08/24 APPR: YCHENG 2022/08/24									
DIVISIONAL SYMBOLS	3 PLACES	±	INITIAL REVISION:								DOCUMENT NUMBER	
	2 PLACES	± 0.25	DRWN: SSHAH 2007/11/16 APPR: JWIENER 2007/11/16								SD-73415-424	
1 PLACE	±	THIRD ANGLE PROJECTION								DOC TYPE	DOC PART	REVISION
0 PLACES	±	DRAWING SERIES								PSD	001	B3
DRAFT WHERE APPLICABLE MUST REMAIN WITHIN DIMENSIONS		C-SIZE		73415		MATERIAL NUMBER		CUSTOMER		SHEET NUMBER		
								GENERAL MARKET		1 OF 3		

DOCUMENT STATUS	P1	RELEASE DATE	2022/08/24	02:18:06
-----------------	----	--------------	------------	----------

- NOTE:
- 10 PITCHES CUMULATIVE TOLERANCE ± 0.20 (.008)
 - BLACK KAPTON TAPE OR EQUIVALENT MUST BE PLACED ON TOP OF CONNECTOR ASSEMBLY.

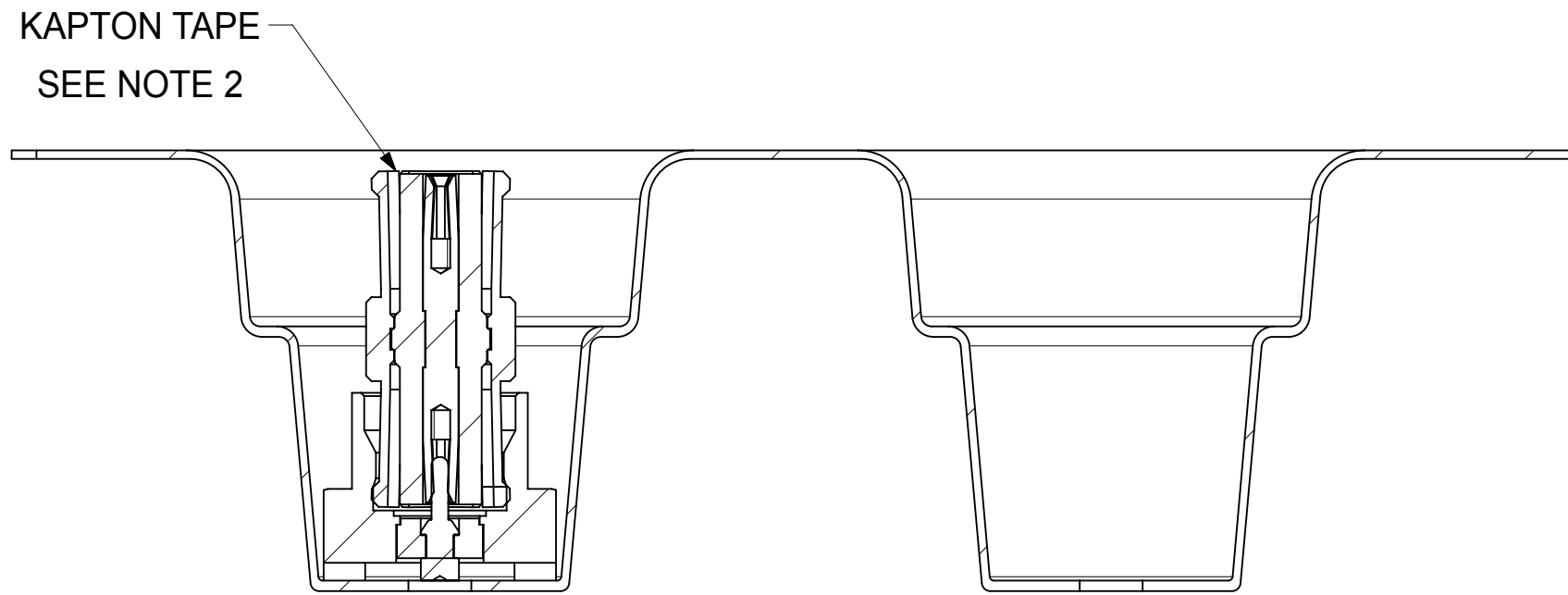
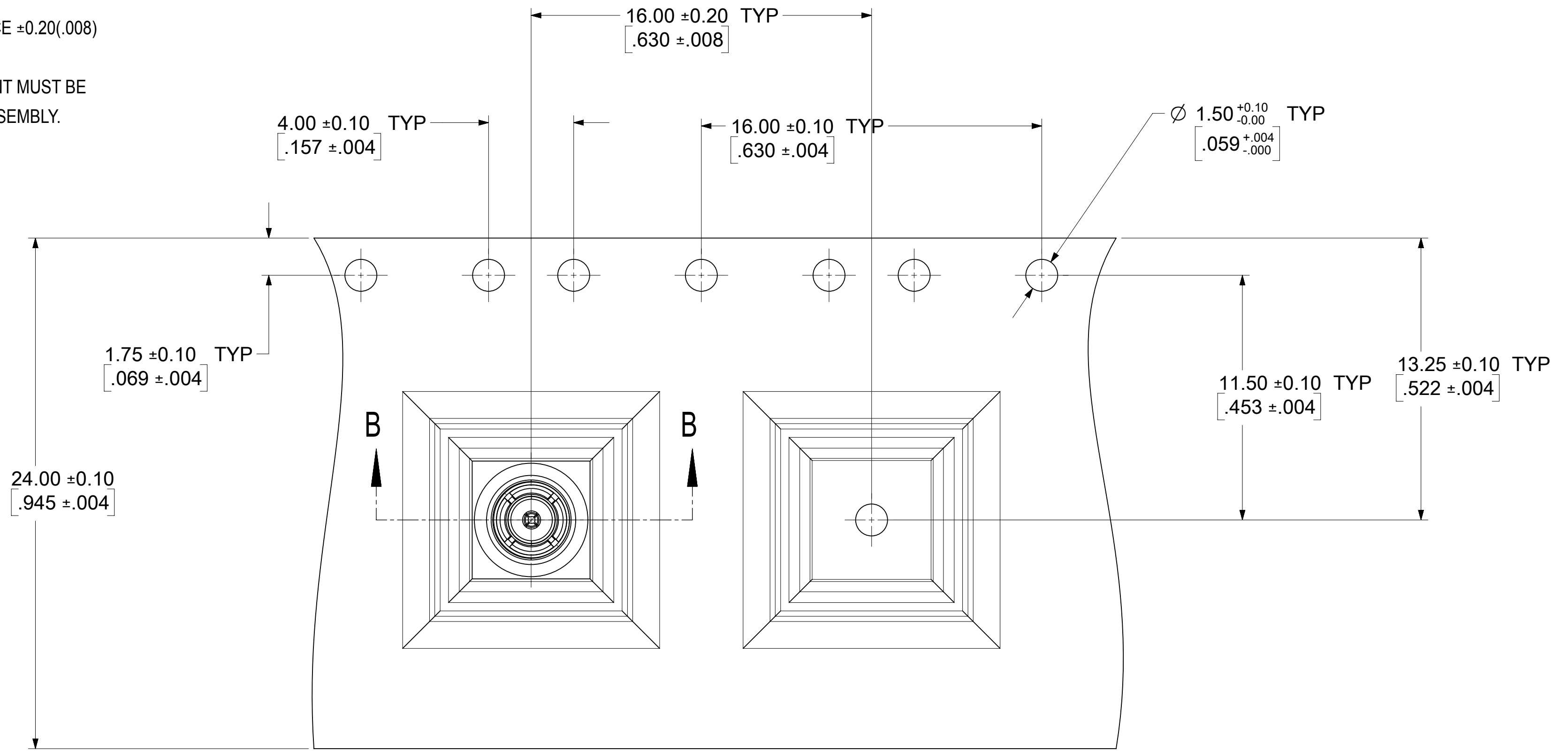

SECTION B-B

THIS DRAWING CONTAINS INFORMATION THAT IS PROPRIETARY TO MOLEX ELECTRONIC TECHNOLOGIES, LLC AND SHOULD NOT BE USED WITHOUT WRITTEN PERMISSION											
FUNCTIONAL SYMBOLS		DIMENSION UNITS		SCALE		CURRENT REV DESC:					
$\nabla A = 0$		MM/INCH		NTS		EWR # 15321-E ADDED -4241 PART NO					
$\nabla C = 0$		GENERAL TOLERANCES (UNLESS SPECIFIED)						EC NO: 718007			
$\nabla P = 0$		ANGULAR TOL $\pm 2.0^\circ$						DRWN: JSU18 2022/08/10			
DIVISIONAL SYMBOLS		4 PLACES		\pm		CHK'D: YCHENG 2022/08/24					
		3 PLACES		\pm		APPR: YCHENG 2022/08/24					
		2 PLACES		± 0.25		INITIAL REVISION:					
		1 PLACE		\pm		DRWN: SSHAH 2007/11/16					
		0 PLACES		\pm		APPR: JWIENER 2007/11/16					
DRAFT WHERE APPLICABLE MUST REMAIN WITHIN DIMENSIONS				THIRD ANGLE PROJECTION		DRAWING		SERIES		DOCUMENT NUMBER	
						C-SIZE		73415		SD-73415-424	
										DOC TYPE DOC PART REVISION	
										PSD 001 B3	
										MATERIAL NUMBER CUSTOMER SHEET NUMBER	
										GENERAL MARKET 2 OF 3	

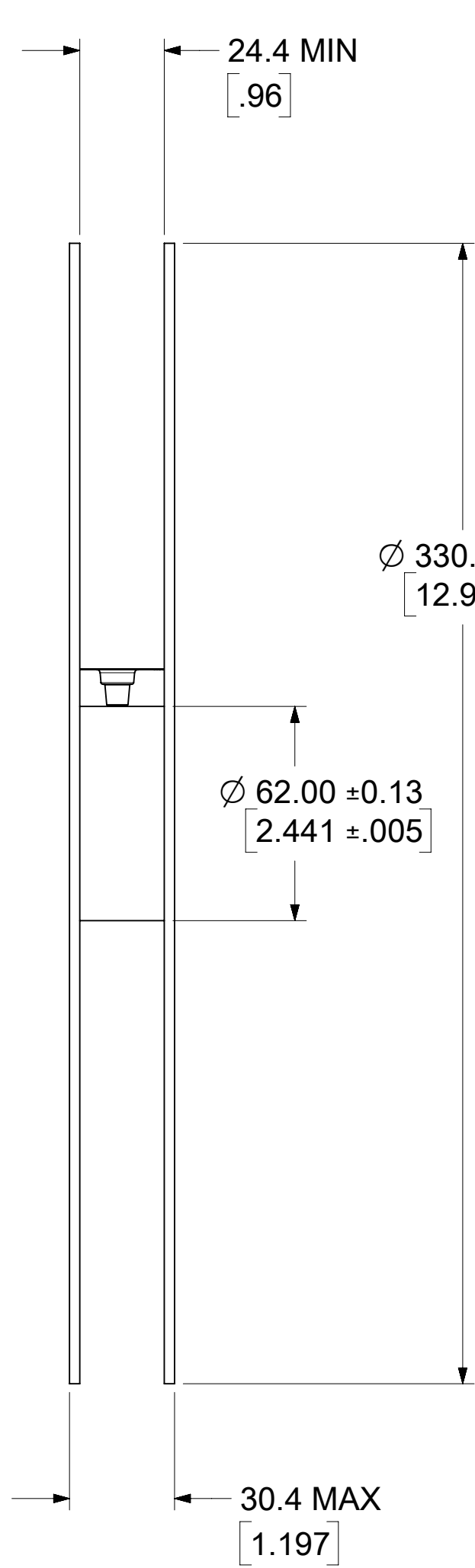

LABEL:
- ORDER NO.
- QUANTITY
- PART NUMBER
- LOT NO.

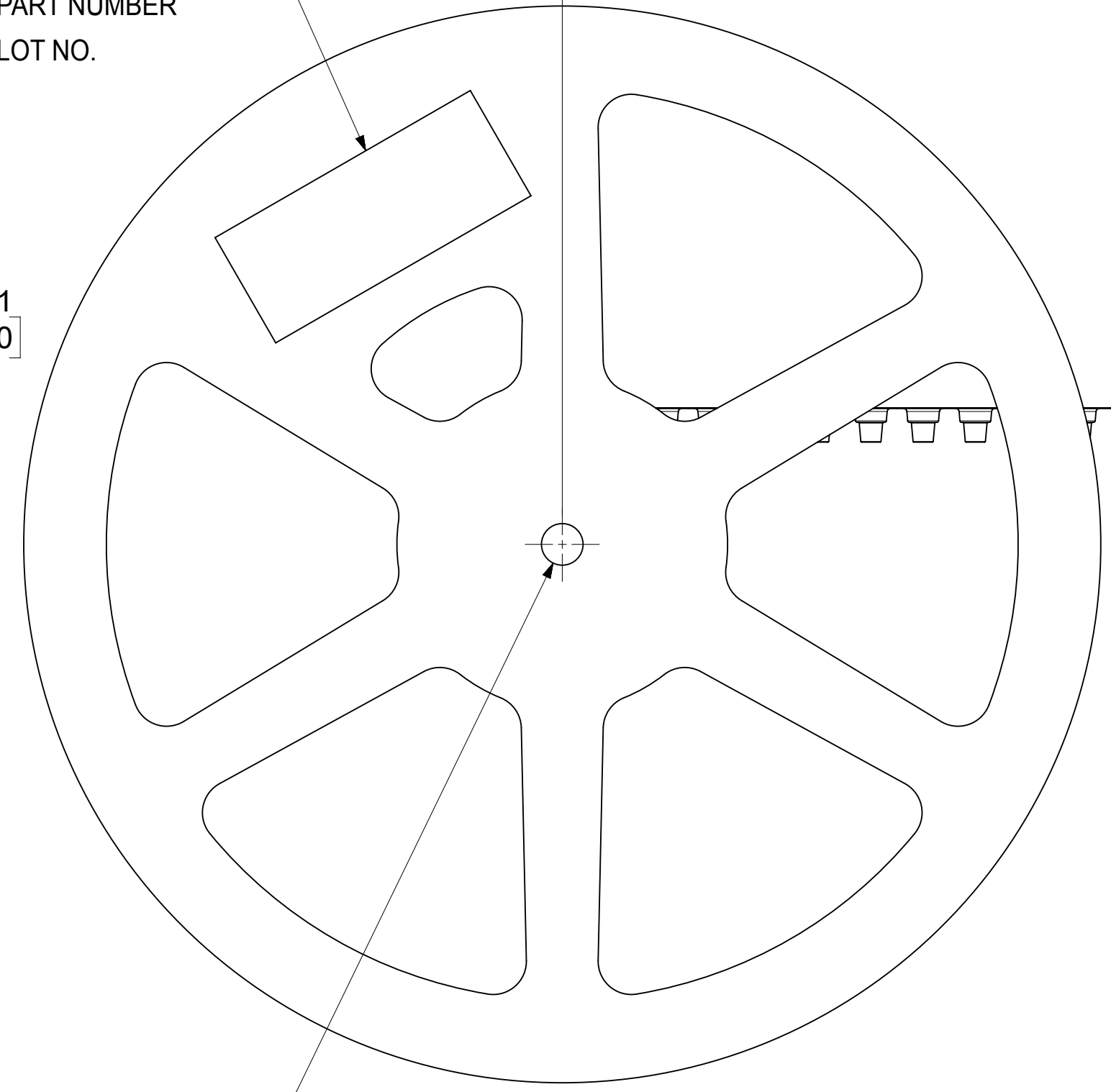

80mm EMPTY UNITS
MINIMUM

ORDER QUANTITY
PACKED WITH 400
COMPONENTS

250mm EMPTY UNITS
MINIMUM

HANDLING DIRECTION →

9.00
[.354]
MIN

FUNCTIONAL SYMBOLS	THIS DRAWING CONTAINS INFORMATION THAT IS PROPRIETARY TO MOLEX ELECTRONIC TECHNOLOGIES, LLC AND SHOULD NOT BE USED WITHOUT WRITTEN PERMISSION											
	DIMENSION UNITS	SCALE	CURRENT REV DESC:									
FA = 0	MM/INCH	NTS	EWR # 15321-E ADDED -4241 PART NO									
DIVISIONAL SYMBOLS	GENERAL TOLERANCES (UNLESS SPECIFIED)		EC NO: 718007								SMP ADAPTER ASSEMBLY 50 OHMS, EWR1994 SMP-P/PCB	
	FC = 0	ANGULAR TOL ± 2.0°		DRWN: JSU18 2022/08/10								
DIVISIONAL SYMBOLS	FP = 0	4 PLACES ±		CHK'D: YCHENG 2022/08/24								PRODUCT CUSTOMER DRAWING DOCUMENT NUMBER: SD-73415-424 DOC TYPE: PSD DOC PART: 001 REVISION: B3
		3 PLACES ±		APPR: YCHENG 2022/08/24								
		2 PLACES ± 0.25		INITIAL REVISION:								
	1 PLACE ±		DRWN: SSHAH 2007/11/16									
	0 PLACES ±		APPR: JWIENER 2007/11/16									
DRAFT WHERE APPLICABLE MUST REMAIN WITHIN DIMENSIONS			THIRD ANGLE PROJECTION	DRAWING	SERIES	MATERIAL NUMBER	CUSTOMER	SHEET NUMBER				
				C-SIZE	73415		GENERAL MARKET	3 OF 3				