

COOPER CATALOG NUMBER	MATERIAL NUMBER	CONDUIT SIZE	N.P.T. FITTING SIZE	LENGTH "M"	DIAMETER "A" REF.	LENGTH "B" REF.	LENGTH "C" REF.	LENGTH "D" REF.	PRODUCT SELECTION NUMBER	UL LISTED	CSA APRVD
36442	1300960057	3/8"	1/2"	3.875±0.500 / 98.43±12.70	1.0 / 25	1.13 / 28.7	0.63 / 16.0	0.88 / 22.4	STB038P-45	YES	YES
36390	1300960044	1/2"	1/2"	4.625±0.500 / 117.48±12.70	1.2 / 30	1.25 / 31.8	0.63 / 16.0	0.88 / 22.4	STB050P-45		
36392	1300960046	1"	1"	7.000±0.500 / 177.80±12.70	1.7 / 43	1.81 / 45.9	0.75 / 19.1	1.38 / 35.1	STB100P-45		
36393	1300960047	1-1/4"	1-1/4"	8.125±1.000 / 206.38±25.40	2.0 / 51	2.31 / 58.7	0.63 / 16.0	1.63 / 41.4	STB125P-45		
36394	1300960048	1-1/2"	1-1/2"	9.250±1.000 / 234.95±25.40	2.5 / 64	2.63 / 66.8	0.63 / 16.0	1.81 / 45.9	STB150P-45		
37036	-----	2-1/2"	2-1/2"	11.250±1.000 / 285.75±25.40	3.6 / 91	3.94 / 100.1	1.06 / 26.9	3.56 / 90.4	STB250P-45		
37037	1300960068	3"	3"	14.750±1.500 / 374.65±38.10	4.3 / 109	4.38 / 111.3	1.19 / 30.2	4.31 / 109.5	STB300P-45		
37038	-----	4"	4"	16.250±1.500 / 412.75±38.10	5.4 / 137	5.50 / 139.7	1.25 / 31.8	4.63 / 117.6	STB400P-45		

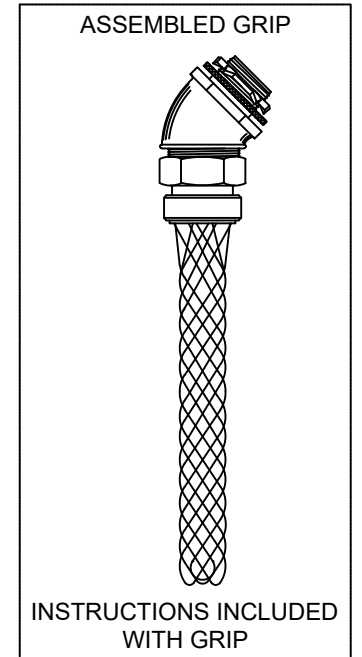
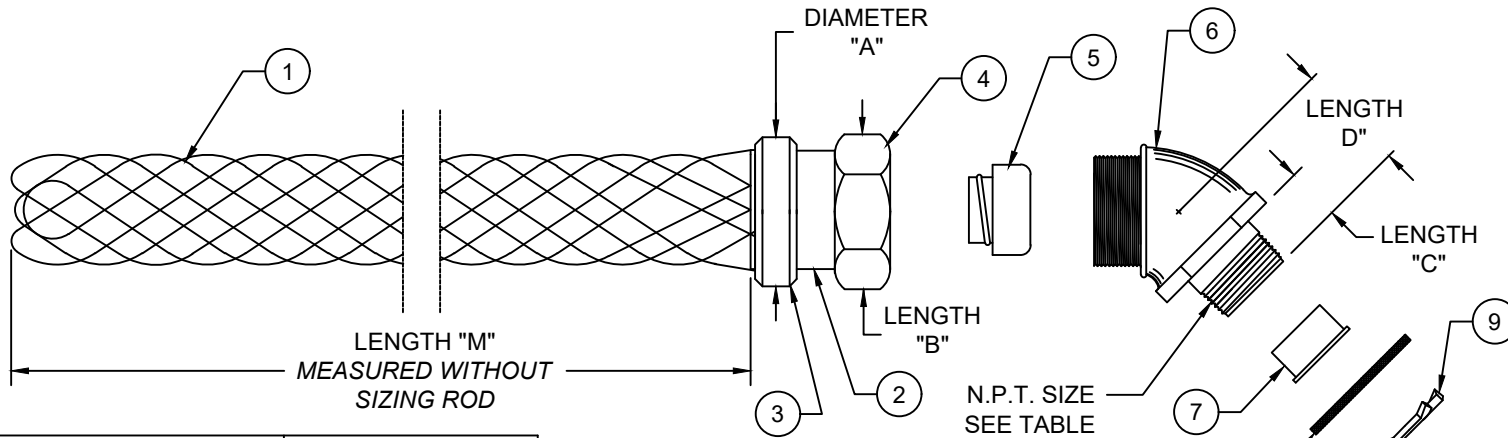

ITEM	DESCRIPTION	MATERIAL
1	WIRE MESH	STAINLESS STEEL
2	INNER RING	ZINC PLATED STEEL
3	OUTER RING	ALUMINUM
4	COMPRESSION NUT	ZINC PLATED STEEL OR MALLEABLE IRON
5	FERRULE	ZINC PLATED STEEL OR ALUMINUM
6	THREADED BODY	ZINC PLATED STEEL OR MALLEABLE IRON
7	THROAT INSULATION	PLASTIC
8	GASKET	NEOPRENE
9	LOCK NUT	ZINC PLATED STEEL

<b>FUNCTIONAL SYMBOLS</b> $\nabla A = 0$ $\nabla C = 0$ $\nabla F = 0$	DIMENSION UNITS: INCH/MM SCALE: NTS		CURRENT REV DESC: OBSOLETE PART NUMBER AS PER PCN#510808																			
	GENERAL TOLERANCES (UNLESS SPECIFIED)		EC NO: 736640																			
	<table border="1"> <tr> <th></th> <th>mm</th> <th>INCH</th> </tr> <tr> <td>4 PLACES</td> <td>± ----</td> <td>± ----</td> </tr> <tr> <td>3 PLACES</td> <td>± ----</td> <td>± 0.005</td> </tr> <tr> <td>2 PLACES</td> <td>± 0.13</td> <td>± 0.01</td> </tr> <tr> <td>1 PLACE</td> <td>± 0.25</td> <td>± 0.02</td> </tr> <tr> <td>0 PLACES</td> <td>± ----</td> <td>± ----</td> </tr> </table>			mm	INCH	4 PLACES	± ----	± ----	3 PLACES	± ----	± 0.005	2 PLACES	± 0.13	± 0.01	1 PLACE	± 0.25	± 0.02	0 PLACES	± ----	± ----	DRWN: SUGEEB 2022/12/21 CHK'D: LIKITV 2023/02/14 APPR: GGA 2023/02/16	
		mm	INCH																			
4 PLACES	± ----	± ----																				
3 PLACES	± ----	± 0.005																				
2 PLACES	± 0.13	± 0.01																				
1 PLACE	± 0.25	± 0.02																				
0 PLACES	± ----	± ----																				
DIVISIONAL SYMBOLS		INITIAL REVISION: DRWN: HRUIZ01 2014/09/23 APPR: JFMURPHY 2015/04/27																				
DRAFT WHERE APPLICABLE MUST REMAIN WITHIN DIMENSIONS		THIRD ANGLE PROJECTION	DRAWING: A-SIZE	SERIES: 130096																		

**STRAIN RELIEF**  
LIQUID TIGHT CONDUIT 45 DEGREE-MALE

PRODUCT CUSTOMER DRAWING

DOCUMENT NUMBER	DOC TYPE	DOC PART	REVISION
SD-130096-102	PSD	001	A1

DOCUMENT STATUS	P1	RELEASE DATE	2023/02/16	05:36:37
MATERIAL NUMBER	SEE TABLE	CUSTOMER	GENERAL MARKET	SHEET NUMBER
				1 OF 1