

REVISIONS					
REV	ECO	DESCRIPTION	DATE	BY	APPR
A1	--	RELEASE NEW DRAWING	16/NOV/22	MILO	TOMMY

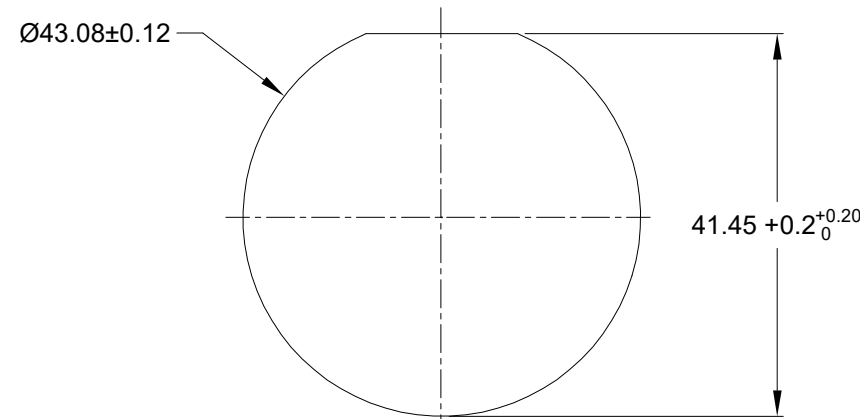
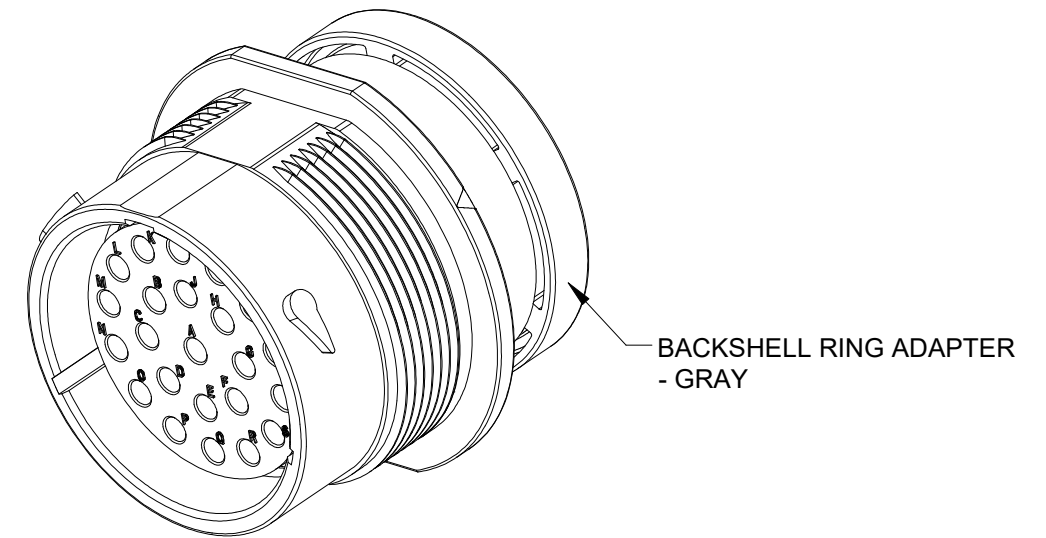
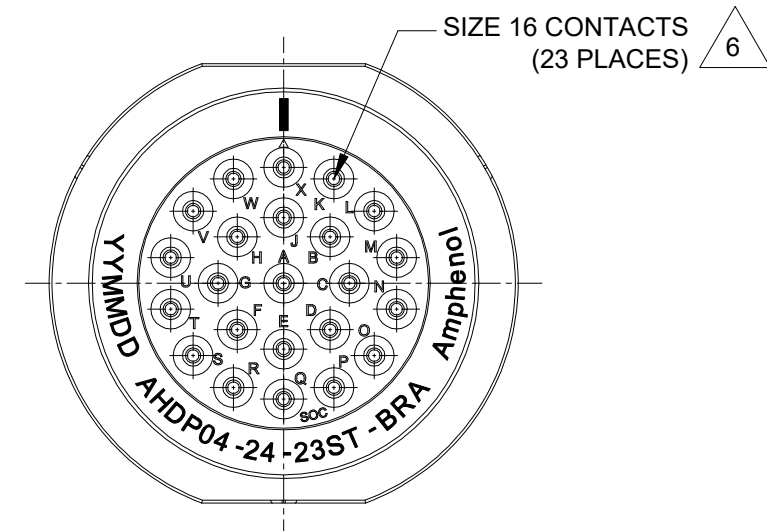
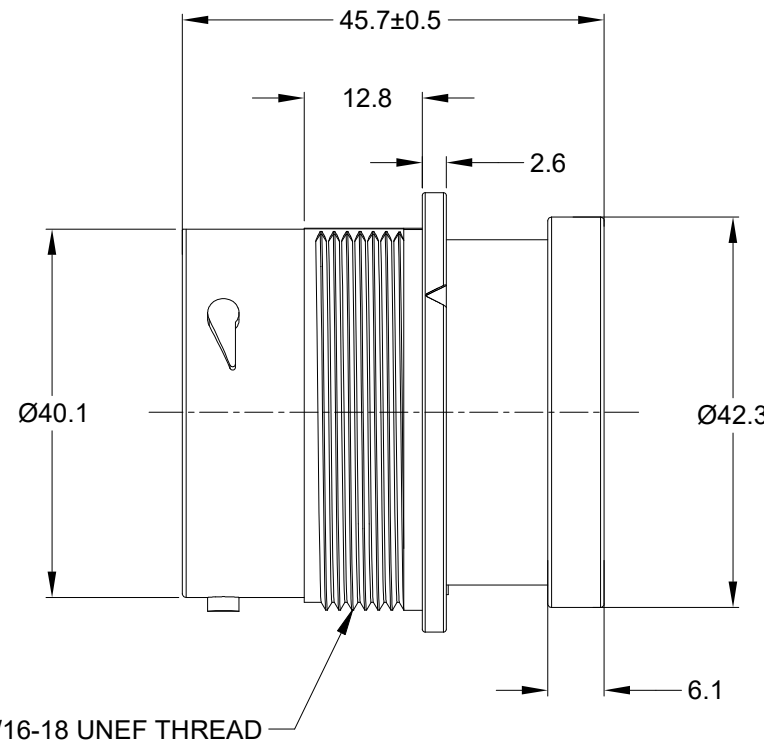
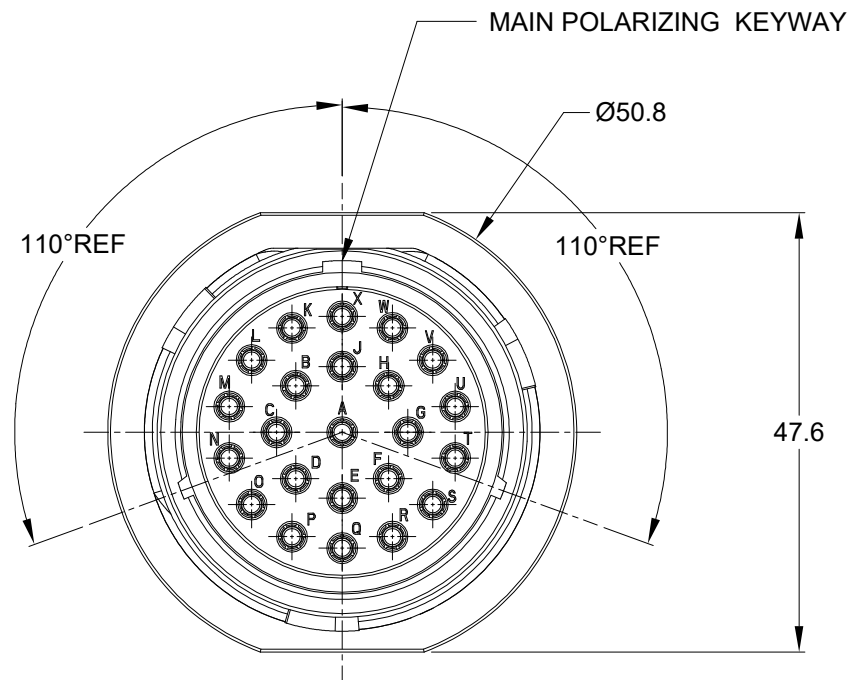

RECOMMENDED PANEL MOUNTING HOLE
RECOMMENDED PANEL THICKNESS: 1.6 TO 4.7MM

NOTES: UNLESS OTHERWISE SPECIFIED

- MATERIAL:
HOUSING: THERMOPLASTIC; BLACK
SEAL: SILICONE RUBBER
- MODIFICATIONS: BACKSHELL RING ADAPTER (BRA);
THIN WALL DIA. WIRE SEAL
- SPECIFICATIONS:
3.1 OPERATING TEMPERATURE: -55°C TO +125°C.
3.2 DIELECTRIC WITHSTANDING VOLTAGE: LESS THAN 2 MILLIAMPS CURRENT LEAKAGE @ 1500 VOLTS AC.
3.3 INSULATION RESISTANCE: 1000 MEGOHM MIN @ 25°C.
3.4 MOISTURE RESISTANCE:
IP68 (IM OF WATER FOR A PERIOD OF 24 HOURS, MATED CONDITION);
IP69K (MATED CONDITION)
3.5 MATING CYCLE DURABILITY: 100 CYCLES
3.6 RoHS COMPLIANT
- MATING PART: AHDP06-24-23P* (* = SEAL TYPE)
- ALL DIMENSIONS ARE FOR REFERENCE USE ONLY.

6 CONTACT SIZE AND WIRE RANGE:

CONTACT SIZE	MIN. INSUL O.D	MAX. INSUL O.D	WIRE RANGE mm ²
16	2.23mm (.088in)	2.69mm (.106in)	14-20AWG (2.0-0.5mm ²)

7. RECEPTACLE IS SUPPLIED WITH DUST CAP (NOT SHOWN).

AHDP04-24-23ST-BRA		REF: HDP24-24-23ST-L017	
QUANTITY	PART NUMBER	DESCRIPTION	ITEM

MATERIALS LIST			
UNLESS OTHERWISE SPECIFIED	SIGNATURES	DATE	
1) All dimensions are in metric (mm). 2) Tolerances are as follows: 1 PL DEC ±0.30 2 PL DEC ±0.15 3 PL DEC ±0.08 3) Note reference = X	DRAWN: MILO.DONG CHECKED: SULLENZHANG ENGINEER: APPROVAL: TOMMY.XIE	16/NOV/22 17/NOV/22 18/NOV/22	
MATERIAL SPECIFICATIONS: WEIGHT: 58.2g	<p>Amphenol</p> <p>Sine Systems - www.amphenol-sine.com 44724 Morley Drive Clinton Township, MI 48036</p> <p>23POS, RECEPTACLE, SOCKET, 24SZ, THIN WIRE SEAL, BRA, AHDP</p>		
PROCESS SPECIFICATIONS:	<p>THIS DRAWING IS SUPPLIED FOR INFORMATION ONLY. DESIGN FEATURES, SPECIFICATIONS AND PERFORMANCE DATA SHOWN HEREON ARE THE PROPERTY OF THE AMPHENOL CORPORATION. NO RIGHTS OF REPRODUCTION ARE IMPLIED. ALL DIMENSIONS ARE SUBJECT TO NORMAL MANUFACTURING VARIATIONS.</p>		
NEXT ASSY:	<p>SIZE: B C- DWG NO: AHDP04-24-23ST-BRA REVISION: A1</p> <p>SCALE: NONE DURAMATE SHEET 1 OF 1</p>		

TITLE: 23POS, RECEPTACLE, SOCKET, 24SZ, THIN WIRE SEAL, BRA, AHDP
DWG NO: AHDP04-24-23ST-BRA
REV: A1
SH: 1
OF: 1