

DESCRIPTION

Demonstration board DC338 features the LTC[®]1563 family of universal lowpass filter building blocks. The LTC1563-2 and LTC1563-3 form a family of easy-to-use active RC lowpass filters with rail-to-rail input and output operation and low DC offset. The parts are suitable for use in systems with resolutions of up to 16-bits.

Demonstration board DC338A-A has the LTC1563-2 installed. The LTC1563-2 with six *equal valued resistors* gives a unity-gain Butterworth response.

Demonstration board DC338A-B has the LTC1563-3 installed. The LTC1563-3 with six *equal valued resistors* gives a unity-gain Bessel response.

The value of the six resistors sets the cutoff frequency for either filter and is calculated by this simple formula:

$$R = 10k \cdot (256kHz/f_c); \text{ where } f_c \text{ is the desired cutoff frequency}$$

By simply using *different valued resistors*, filters with gain and other response types are achieved. A specific gain (H_0), f_0 and Q requirement is met with a unique set of three resistors. To design these filters use Linear Technology's FilterCAD[™] filter design software. FilterCAD is a powerful, yet easy to use, program available free of charge from the LTC website (www.linear-tech.com). It is also available on CD-ROM.

This board is intended for use in evaluating simple, all pole lowpass filters using the LTC1563 family of parts. The filter complexity ranges from 4th to 6th order. The reference designators on the board correspond directly with the schematics produced with Linear Technology's FilterCAD filter design program. With FilterCAD, the design of filters is a simple process. With the LTC1563 and this demonstration board, filter evaluation and integration are also simple.

LT, LTC and LT are registered trademarks of Linear Technology Corporation. FilterCAD is a trademark of Linear Technology Corporation.

TYPICAL PERFORMANCE CHARACTERISTICS AND BOARD PHOTO

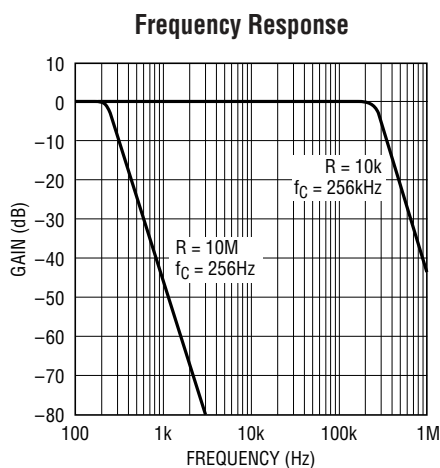

Demo Board



DEMO MANUAL DC338A

Universal Lowpass Filter Board

PACKAGE AND SCHEMATIC DIAGRAMS

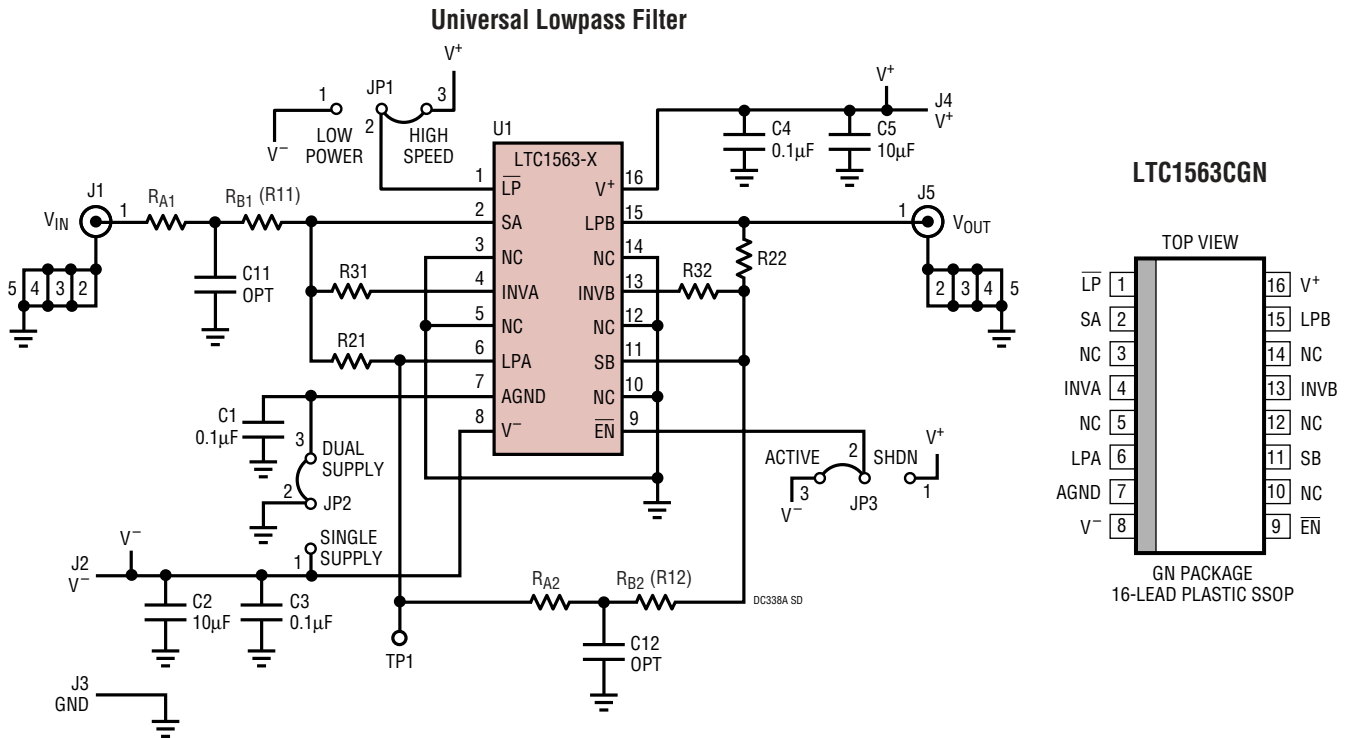

- NOTES: UNLESS OTHERWISE SPECIFIED
1. ALL RESISTORS ARE OPTIONAL AND IN 0805 PACKAGE.
 2. ALL CAPACITORS ARE IN 0805 PACKAGE.
 3. INSTALL SHUNTS ON JP1-JP3 PIN 2 AND PIN 3.
 4. THERE ARE TWO TYPES OF ASSEMBLIES. LTC1563-2 AND LTC1563-3.

Figure 1. Demo Board Schematic

PARTS LIST

REFERENCE DESIGNATOR	QUANTITY	PART NUMBER	DESCRIPTION	VENDOR	TELEPHONE
C1, C3, C4	3	0805YG104ZAT1A	0.1µF 16V 80% Y5V Capacitor	AVX	(843) 946-0362
C2, C5	2	1206ZG106ZAT1A	10µF 10V 80% Y5V Capacitor	AVX	(843) 946-0362
C11, C12	0	TBD	Capacitor (Optional)	TBD	
JP1-JP3	3	3801S-3G2	1× 3-Pin 1 Row 0.100cc JMP	Comm Con	(626) 301-4200
	3	CCIJ-230G	0.100cc Shunt	Comm Con	(626) 301-4200
J1, J5	2	112404	BNC Connector	Connex	(805) 378-6464
J2-J4	3	575-4	Banana Jack Standard Conn	Keystone	(718) 956-8900
RB1, RA1, RB2, RA2, R21, R22, R23, R31, R32	0		Resistor (Optional)	TBD	
TP1	1	2501-2	1-Pin Terminal Turrent TP	Mill-Max	(516) 922-6000
U1(-A Assembly)	1	LTC1563-2	LTC1563-2 SSOP16GN	LTC	(408) 432-1900
U1(-B Assembly)	1	LTC1563-3	LTC1563-3 SSOP16GN	LTC	(408) 432-1900

QUICK START GUIDE

1. Design the filter using FilterCAD V3.0 (or later). When the design is complete, the schematic's reference designators match those used on this board.
2. Solder the resistors to the board. The board is designed for 0805 sized surface mount resistors although other sizes can be used with some care.
3. Check the JP1 jumper setting. If the FilterCAD schematic shows Pin 1 of the LTC1563 connected to V^+ , make certain that JP1 is in the HIGH SPEED position. If the FilterCAD schematic shows Pin 1 of the LTC1563 connected to V^- , JP1 is placed in the LOW POWER position.
4. Connect jumper JP2 in the DUAL SUPPLY position for split supplies (V^+ , V^- and GND). Connect JP2 in the SINGLE SUPPLY position for single-supply operation (V^+ and GND).
5. Set jumper JP3 to the ACTIVE position to enable the LTC1563 for normal operation. This jumper should be placed in the SHUTDOWN position only if you want to test the part's shutdown function.
6. Connect the power supply to the V^+ , V^- and GND banana jacks. For single-supply operation, connect the V^- and GND banana jacks together.
7. Apply the input signal to the V_{IN} BNC connector.
8. Connect the V_{OUT} BNC connector to your monitoring device (oscilloscope, network analyzer, etc). Make certain that the loading is not excessive. The output of LTC1563 is connected directly to the V_{OUT} BNC. There is no buffering on this board. The LTC1563 cannot drive a 50Ω load. It may also oscillate when connected to a large capacitive load. Driving any significant length of cable is to be avoided. Consult the LTC1563 data sheet for more details on output loading issues.

OPERATION

LT1563 Functional Description

The LTC1563-2/LTC1563-3 are a family of easy-to-use, 4th order lowpass filters with rail-to-rail operation. The LTC1563-2, with a single resistor value, gives a unity-gain filter approximating a Butterworth response. The LTC1563-3, with a single resistor value, gives a unity-gain filter approximating a Bessel (linear phase) response. The proprietary architecture of these parts allows for a simple unity-gain resistor calculation:

$$R = 10k(256kHz/f_c)$$

where f_c is the desired cutoff frequency. For many applications, this formula is all that is needed to design a filter. For example, a 50kHz filter requires a 51.2k resistor. In practice, a 51.1k resistor would be used as this is the closest E96, 1% value available.

The LTC1563-X is constructed with two independent 2nd order sections. The output of the first section (section A)

is fed into the second section (section B). Note that section A and section B are similar but not identical. The parts are designed to be simple and easy to use.

By using different valued resistors, gain, other transfer functions and higher cutoff frequencies are achieved. For these applications, the resistor value calculation is more difficult. For best results, design these filters using FilterCAD Version 3.0 (or later).

Using TEE Networks

Figure 2 illustrates the use of an input TEE network to form an additional pole. The R_1 input resistor is split into two parts with an additional capacitor connected to ground in between the resistors. This TEE network forms a single real pole. R_{B1} should be much larger than R_{A1} to minimize the interaction of this pole with the 2nd order section. This circuit is useful in forming dual 3rd order filters and 5th order filters with a single LTC1563 part. By cascading two parts, 7th order and 9th order filters are achieved.

OPERATION

A TEE network can be used in both sections of the part to make a 6th order filter. This 6th order filter does not conform exactly to the textbook responses. Textbook 6th order responses (Butterworth, Bessel, Chebyshev etc.) all have three complex pole pairs. This filter has two complex pole pairs and two real poles. The textbook response always has one section with a low Q value between 0.5 and 0.6. Replacing this low Q section with two real poles (two real poles are the same mathematically as a complex pole pair with a Q of 0.5) and tweaking the Q of the other two complex pole pair sections results in a filter that is indistinguishable from the textbook filter.

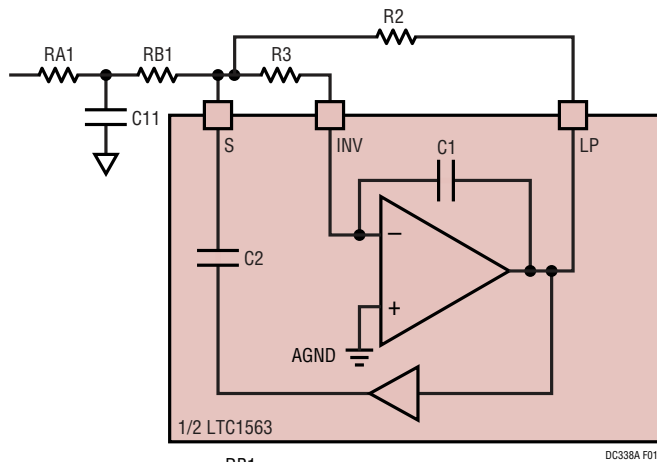

$$RA1 \approx \frac{RB1}{10}$$

$$f_p = \frac{1}{2\pi \cdot \left(\frac{RA1 \cdot RB1}{RA1 + RB1} \right) C11}$$

Figure 2. Input TEE Network

INPUT CONFIGURATION FOR EACH SECTION

The LTC1563 consists of two independent 2nd order sections. Each section of the board is designed such that the input can be set up in one of three configurations. The input section has three positions: RA1, RB1(R11) and C11 for section A and RA2, RB2(R12) and C12 for section B. The connection and labeling of section A is shown below.

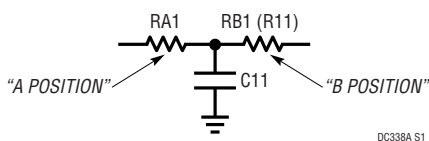

Note that the RB1 resistor is double labeled as RB1(R11). This is done to conform with the schematic that FilterCAD provides. If the section is 3rd order, using a TEE network, the two resistors are labeled as RA1 and RB1 (RA2 and RB2 for section B) by FilterCAD. If the section is a standard 2nd order, the one resistor is labeled R11 (R12 for section B) by FilterCAD.

1. Standard 2nd Order Configuration

In this configuration the input consists of a single resistor. Place the resistor in the board's "B" position. Place a 0Ω resistor in the "A" position. Leave the capacitor position open.

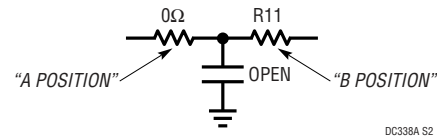

DC338A S2

2. 3rd Order Section with Input "TEE" Network

In this configuration use all three positions exactly as labeled. The reference designators match FilterCAD exactly.

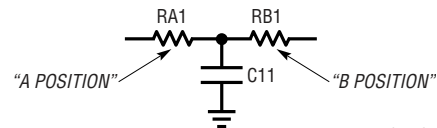

DC338A S3

3. AC-Coupled 2nd Order Section

In this configuration connect the AC coupling capacitor in the "A" position on the board. Place the resistor in the "B" position. Leave the capacitor position (C11 or C12) open.

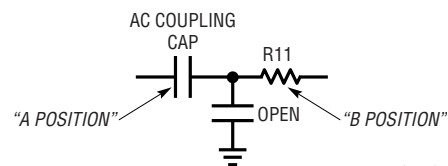

DC338A S4

OPERATION

Cutoff Frequency (f_c) and Gain limitations

The LTC1563-X has both a maximum f_c limit and a minimum f_c limit. The maximum f_c limit is set by the speed of the LTC1563-X's op amps. At the maximum f_c , the gain is also limited to unity.

A minimum f_c is dictated by the practical limitation of reliably obtaining large valued, precision resistors. As the desired f_c decreases, the resistor value required increases. When f_c is 256Hz, the resistors are 10M. Obtaining a reliable, precise 10M resistance between two points on a printed circuit board is somewhat difficult. For example, a 10M resistor with 200M of stray, layout related resistance in parallel, yields a net effective resistance of 9.52M and an error of -5% . Note that the gain is also limited to unity at the minimum f_c .

At intermediate f_c , the gain is limited by one of the two factors discussed above. For best results, design filters with gain using FilterCAD.

FilterCAD calculates the resistor values using an accurate and complex algorithm to account for parasitics and op amp limitations. Using FilterCAD will always yield the best possible design. By using the FilterCAD design tool you can also achieve filters with cutoff frequencies beyond 256kHz. Cutoff frequencies up to 360kHz are attainable.

Contact Linear Technology for a copy of the FilterCAD software. FilterCAD can also be downloaded from our website at www.linear-tech.com.

Output Loading: Resistive and Capacitive

The op amps of the LTC1563-X have a rail-to-rail output stage. To obtain maximum performance, the output loading effects must be considered. Output loading issues can be divided into resistive effects and capacitive effects.

Resistive loading affects the maximum output signal swing and signal distortion. If the output load is excessive, the output swing is reduced and distortion is increased. All of the output voltage swing testing on the LTC1563-X is done with $R_{22} = 100k$ and a 10k load resistor. For best undistorted output swing, the output load resistance should be greater than 10k.

Capacitive loading on the output reduces the stability of the op amp. If the capacitive loading is sufficiently high, the stability margin is decreased to the point of oscillation at the output. Capacitive loading should be kept below 30pF. Good, tight layout techniques should be maintained at all times. These parts should not drive long traces and must never drive a long coaxial cable. *When probing the LTC1563-X, always use a 10x probe. Never use a 1x probe.* A standard 10x probe has a capacitance of 10pF to 15pF while a 1x probe's capacitance can be as high as 150pF. The use of a 1x probe will probably cause oscillation.

For larger capacitive loads, a series isolation resistor can be used between the part and the capacitive load. If the load is too great, a buffer must be used.

NOTE: The output of the LTC1563 is connected directly to the V_{OUT} BNC. There is no buffering on this board.

TYPICAL APPLICATIONS

$\pm 5V$, 2.3mA Supply Current, 20kHz, 4th Order, 0.5dB Ripple Chebyshev Lowpass Filter

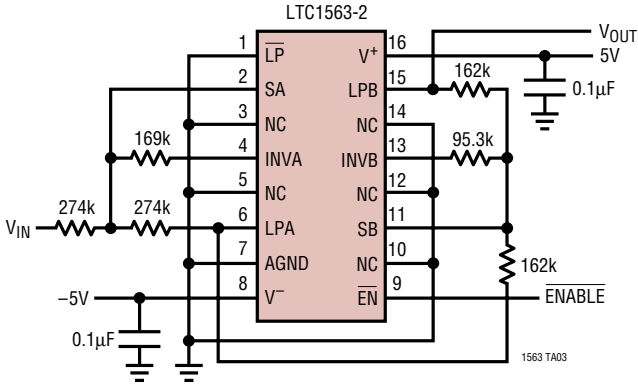

Frequency Response

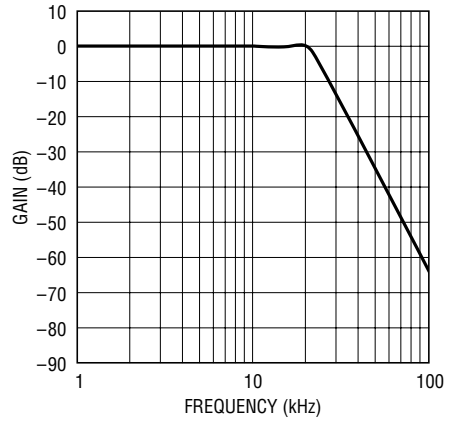

1563 TA04

Single 3.3V, 2mA Supply current, 20kHz 8th Order Butterworth Lowpass Filter

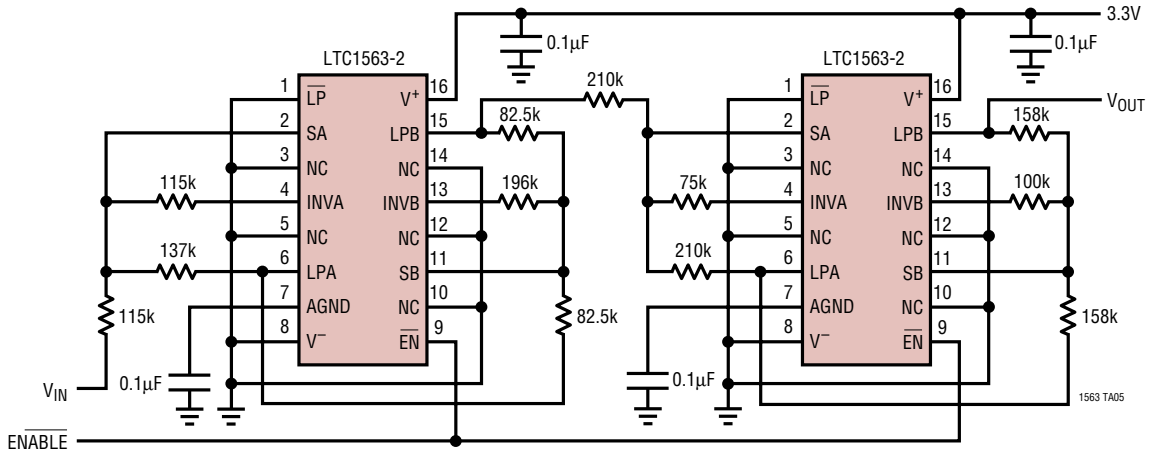

Frequency Response

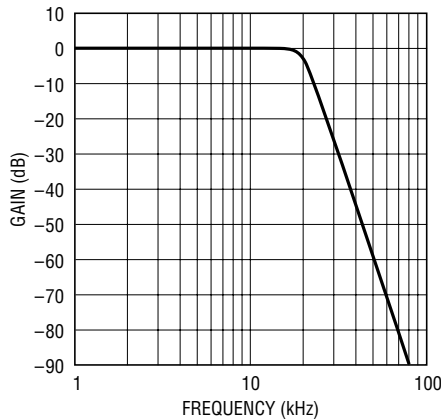

1563 TA06

PCB LAYOUT AND FILM

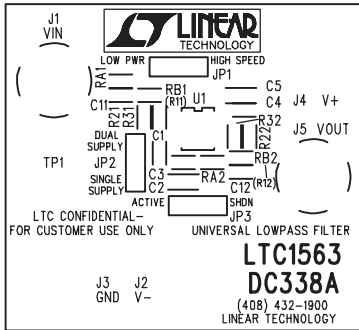

Silkscreen Top

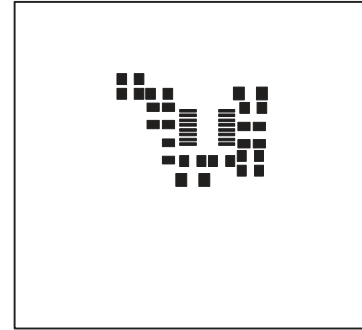

Paste Mask Top

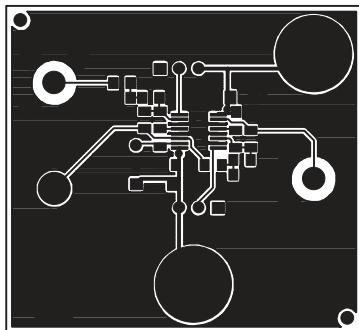

Component Side

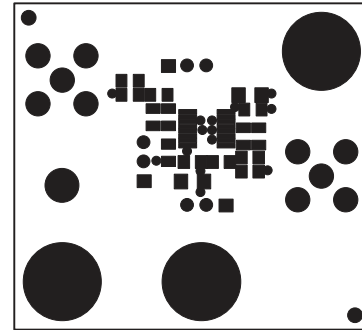

Solder Mask Top

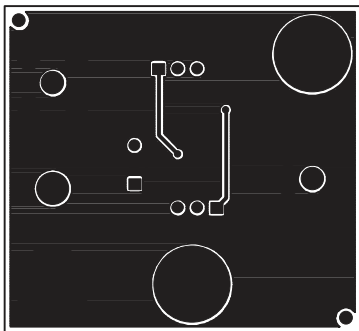

Solder Side

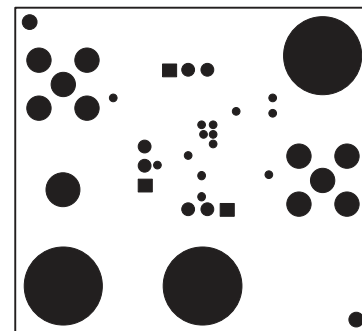

Solder Mask Bottom

DEMO MANUAL DC338A

Universal Lowpass Filter Board

PC FAB DRAWING

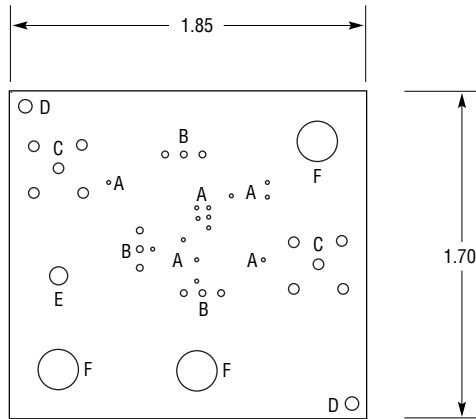

NOTES: UNLESS OTHERWISE SPECIFIED

1. MATERIAL: FR4 OR EQUIVALENT EPOXY, 2 OZ. COPPER CLAD THICKNESS 0.062 ± 0.006 TOTAL OF 2 LAYERS.
2. FINISH: ALL PLATED HOLES 0.001 MIN/0.0015 MAX COPPER PLATE ELECTRODEPOSITED TIN-LEAD COMPOSITION BEFORE REFLOW, SOLDER MASK OVER BARE COPPER (SMOBC)
3. SOLDER MASK: BOTH SIDES USING LPI OR EQUIVALENT.
4. SILKSCREEN: USING WHITE NON-CONDUCTIVE EPOXY INK.
5. UNUSED SMD COMPONENTS SHOULD BE FREE OF SOLDER.
6. FILL UP ALL VIAS WITH SOLDER.
7. SCORING:

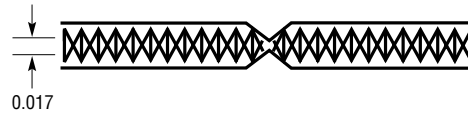

SYMBOL	DIAMETER	NUMBER OF HOLES	PLATED
A	0.02	14	YES
B	0.035	9	YES
C	0.055	10	YES
D	0.07	2	NO
E	0.094	1	YES
F	0.21	3	YES
TOTAL HOLES		39	

338 FAB DWG