

RECOMMENDED P.C.B LAYOUT
(TOLERANCE:±0.05)

NOTES:

- 1. Material:
 - 1.1 Housing: PBT+30%GF UL94V-0, Color White
 - 1.2 Shell: Brass
 - 1.3 Contact :Phosphor Bronze
- 2. FINISH:
 - 2.1 Contact Area: Selective 30u"Au
 - Solder Area: Tin Plated
 - Under: Ni Plated
- 3. MECHANICAL:
 - 3.1 Mating Force: 3.57kgf Max.
 - 3.2 Unmating Force: 1.02kgf Min
 - 3.3 Durability: 1500 cycles Min
- 4. ELECTRICAL:
 - 4.1 Current Rating: 1.5A
 - 4.2 Dielectric Strength: 500V AC FOR 1 MINUTE
 - 4.3 Contact Resistance: 30mΩ Max
 - 4.4 Insulation Resistance: 1000 MΩ Min
- 5. Operating temperature: -55°C TO +85°C
Waving soldering temperature :265°C, 5S Max
- 6. PACKING: Tray

RoHS compliant

Scale	Free					Date	Name	Customer-No.
TOLERANCE					Drawn	14.07.2014	Winnie	
.X	±0.38							
.XX	±0.25	③	Change of production plant	11.04.2019	Xavier	Approved	03.02.2018	Tom
.XXX	±0.13	②	Update	03.02.2018	Tom			
DIM	TOL	①	Add the waving soldering temperature	20.07.2017	Winnie			
X.°	±5°	①	Drawn	14.07.2014	Winnie			
Angle	TOL	①						
UNIT	mm	ld.	Modification	Date	Name			

Customer-No.		
ASSMANN WSW-No.		AU-Y1005-2
Drawing-No.		
ASS 6506 CO		rev03
Replace	SHEET	
	1/2	

1

2

3

4

5

6

7

A

A

B

B

C

C

D

D

E

E

F

F

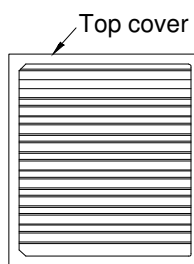
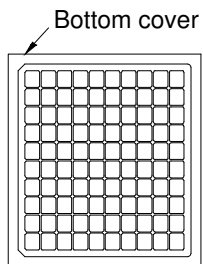
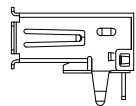

100pcs/Tray

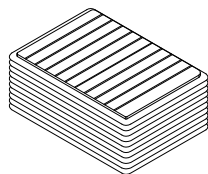

10 Trays

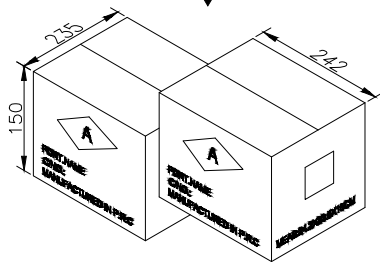

Inner box

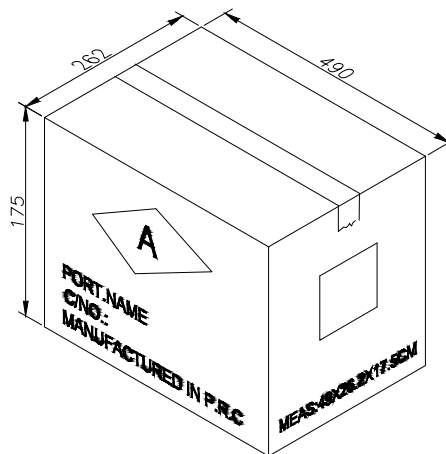

Master carton

NOTES:

- 1.Place 10 trays into an inner box, total 1000pcs/box;
- 2.Place 2 boxes into a master carton, total 2000pcs/carton.

RoHS compliant

Scale	Free					Date	Name	Customer-No.	
TOLERANCE					Drawn	14.07.2014	Winnie	ASSMANN WSW-No. AU-Y1005-2	
.X	±0.38	③	Change of production plant	11.04.2019	Xavier	Approved	03.02.2018		Drawing-No. ASS 6506 CO
.XX	±0.25	②	Update	03.02.2018	Tom				
.XXX	±0.13	①	Add the waving soldering temperature	20.07.2017	Winnie	ASSMANN WSW components		rev03	
DIM	TOL	①	Drawn	14.07.2014	Winnie			Replace	SHEET
X.°	±5°							2/2	
Angle	TOL	①							
UNIT	mm	Id.	Modification	Date	Name				

1

2

3

4

5

6

7

H

H