

1245UMFT

Universal modular fuse, time delay, SMT



Product features

- 12.5 x 4.8 x 4.8 mm surface mount package
- Complies with IEC60127-4 Universal modular fuse-links
- Time delay
- 250 Vac Voltage rating brick fuse
- Ceramic square body with end cap design
- Moisture sensitivity level (MSL): 1

Applications

- Power supply
- White goods
- Lighting system
- Industrial equipment
- Lighting ballast
- AC/DC adaptor primary protection
- Medical Equipment
- Battery protection
- LCD monitor
- Office electronic equipment
- Industrial equipment

Agency information

Universal modular fuse: UL file number: E526626



Environmental compliance



Ordering part number

The ordering code is the packaging code and part number replacing the "." with a "-" i.e. 1.25=1-25

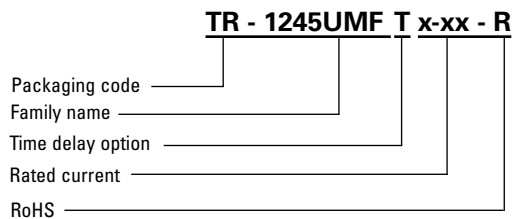

Packaging prefix

TR- (1000 parts on a 13" diameter tape and reel)











Powering Business Worldwide

Electrical characteristics

Amp Rating	1.25 In minimum	2 In maximum	10 In
1.0 A ~ 6.3 A	1 hour	120 seconds	10 - 100 milliseconds

Product specifications

Part number	Current rating (A)	Voltage rating (Vac)	Interrupting rating @ rated voltage ¹ (A) Vac	Typical cold resistance ² (mΩ)	Typical voltage drop (mV)	Part marking
1245UMFT1-R	1	250	100	118	165	BUSS T1AL AC250V 
1245UMFT1-25-R	1.25	250	100	85	150	BUSS T1.25AL AC250V 
1245UMFT1-6-R	1.6	250	100	62	140	BUSS T1.6AL AC250V 
1245UMFT2-R	2	250	100	42	116	BUSS T2AL AC250V 
1245UMFT2-5-R	2.5	250	100	33	115	BUSS T2.5AL AC250V 
1245UMFT3-15-R	3.15	250	100	23.6	95	BUSS T3.15AL AC250V 
1245UMFT4-R	4	250	100	20	125	BUSS T4AL AC250V 
1245UMFT5-R	5	250	100	14.5	100	BUSS T5AL AC250V 
1245UMFT6-3-R	6.3	250	100	11	100	BUSS T6.3AL AC250V 

1. AC Interrupting rating (measured at rated voltage, >95% power factor);

2. Typical cold resistance is measured at <10% of rated current in ambient temperature of +25 °C

Dimensions- mm

Drawing not to scale

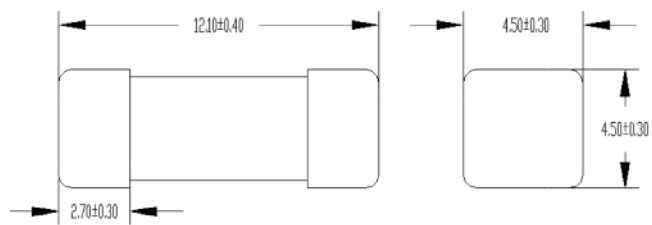

Recommended pad layout

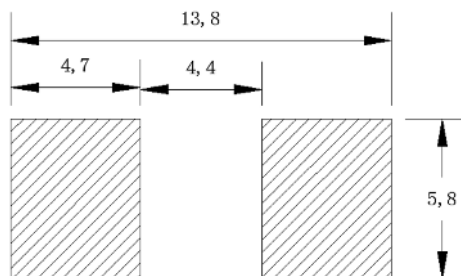

Recommended trace thickness is 35 μm;
the minimum trace width is 5 mm
Recommended stencil thickness is 0.15 mm

General specifications

Operating temperature: -40 °C to +125 °C with proper derating factor applied

Thermal shock: MIL-STD-202, Method 107, -40 °C to +125 °C, number of cycles 1000, transfer time 20 seconds, dwell time 15 minutes air-air.

Mechanical shock: MIL-STD-202, Figure 1 of Method 213, Condition C, 100 g, 6 ms

Vibration: MIL-STD-202 Method 201, 2 hours each of 3 orientations. Test from 10 - 55 Hz in 1 minute

Resistance to solder heat: MIL-STD-202 Method 210, Solder temperature +260 °C ± 5 °C, solder immersion time 10 s ± 5 s

Solderability test: J-STD-002, Method B1 Steam aging 1 hour, Solder temperature +255 °C ± 5 °C, solder immersion time 5 s

Humidity bias: MIL-STD-202 Method 103, 1000 hours +85 °C/85% RH. Specified conditions: 10% of operating power.

Breaking capacity: Spec, Ambient Temperature +25 °C + -5 °C UMF-6.3 A: 250 Vac, 100 A

High temperature operating life: MIL-STD-202 Method 108, Condition D, Steady state +70 °C at 60% rated current.

Packaging information - mm

1000 parts per 13" diameter reel (EIA-481 compliant)
 Drawing not to scale

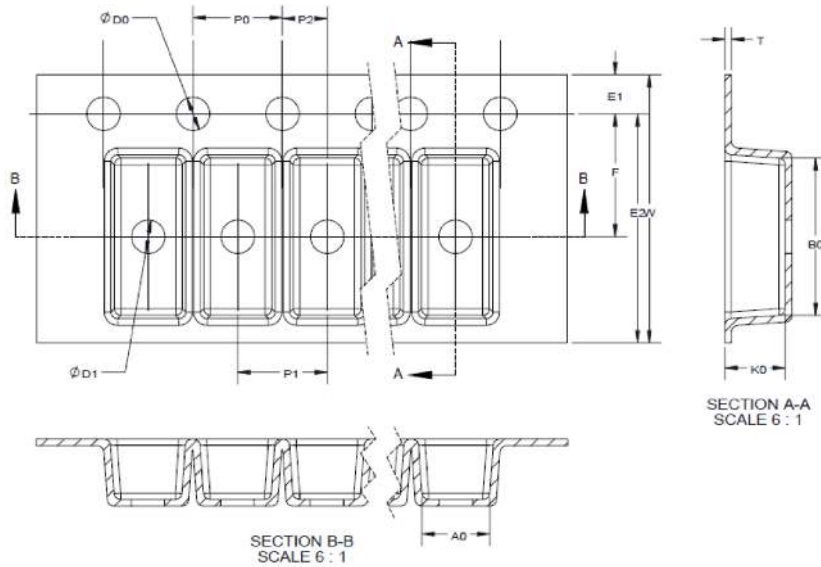

Dimension	millimeter
W	24.00
F	11.50
E1	1.75
E2	N/A
P0	4.00
P1	8.00
P2	2.00
D0	1.50
D1	1.50
A0	4.85
B0	12.75
K0	4.90
T	0.40

Reel dimension- mm

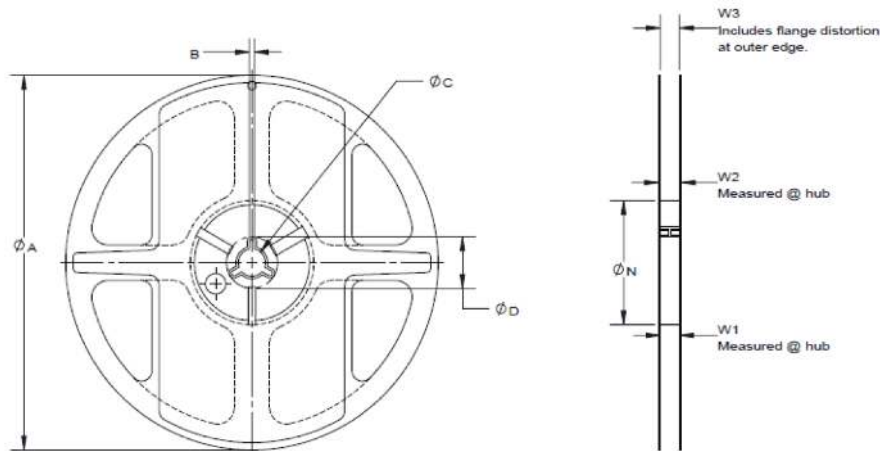

Dimension	millimeter
A	330 ± 1
B	2.5 ± 0.2
C	13.5 ± 0.2
D	N/A
N	100 ± 0.5
W1	24.8 ± 0.5
W2	30.4 max
W3	N/A

Temperature derating curve

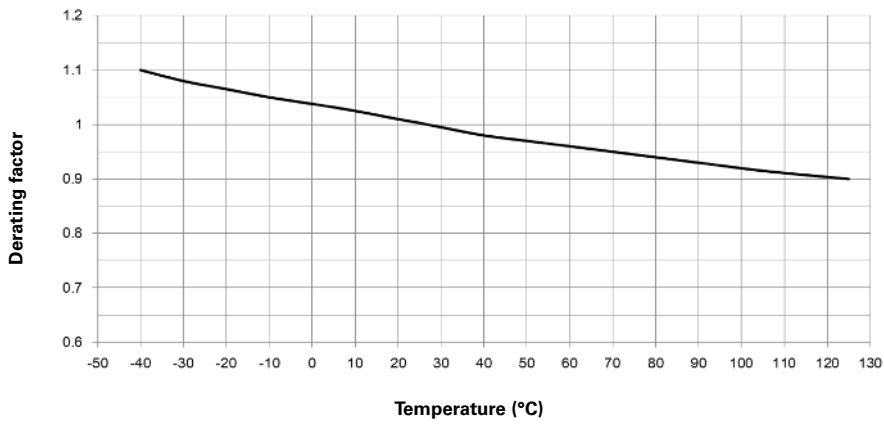

Current vs. time curve

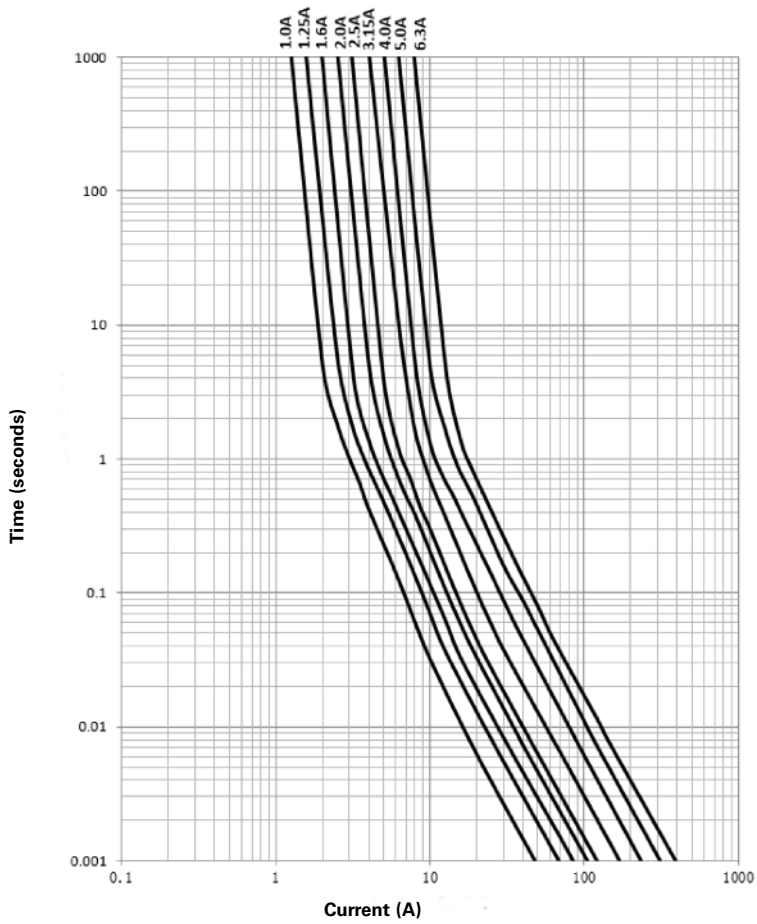

I²t vs time curve

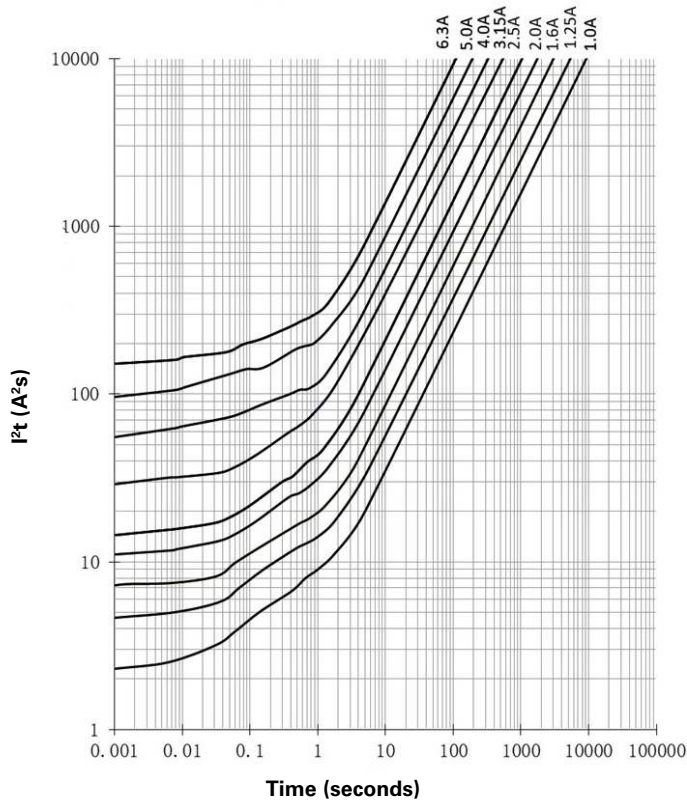

I²t vs current curve

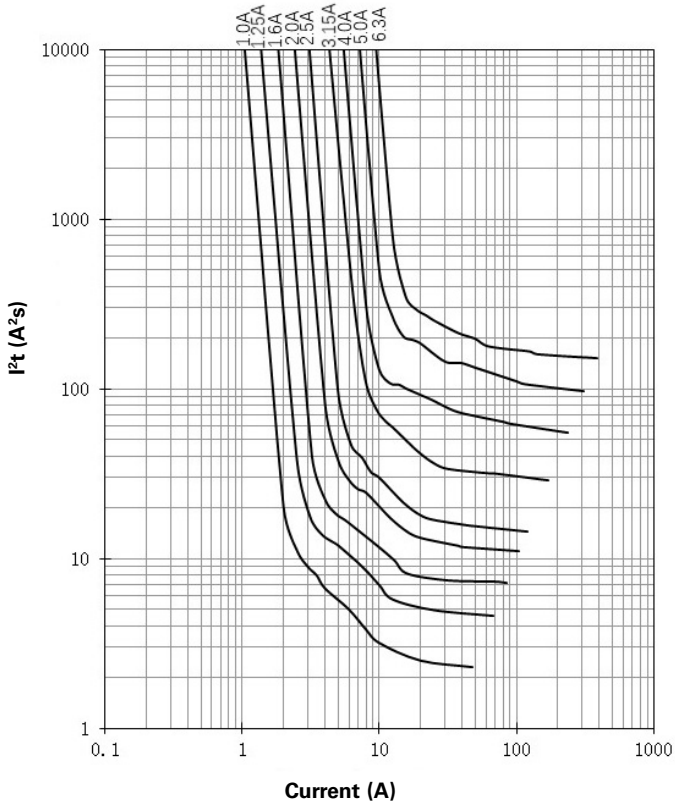

Wave solder profile

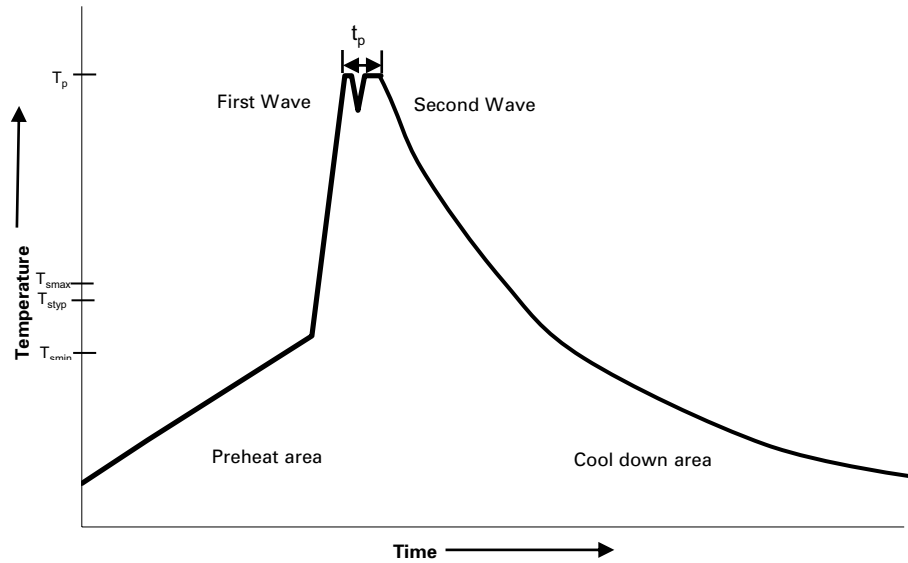

Reference EN 61760-1:2006

Profile feature	Standard SnPb solder	Lead (Pb) free solder
Preheat	• Temperature min. (T_{smin})	100 °C
	• Temperature typ. (T_{styp})	120 °C
	• Temperature max. (T_{smax})	130 °C
	• Time (T_{smin} to T_{smax}) (t_s)	70 seconds
Δ preheat to max Temperature	150 °C max.	150 °C max.
Peak temperature (T_p)*	235 °C – 260 °C	250 °C – 260 °C
Time at peak temperature (t_p)	10 seconds max 5 seconds max each wave	10 seconds max 5 seconds max each wave
Ramp-down rate	~ 2 K/s min ~3.5 K/s typ ~5 K/s max	~ 2 K/s min ~3.5 K/s typ ~5 K/s max
Time 25 °C to 25 °C	4 minutes	4 minutes

Solder reflow profile

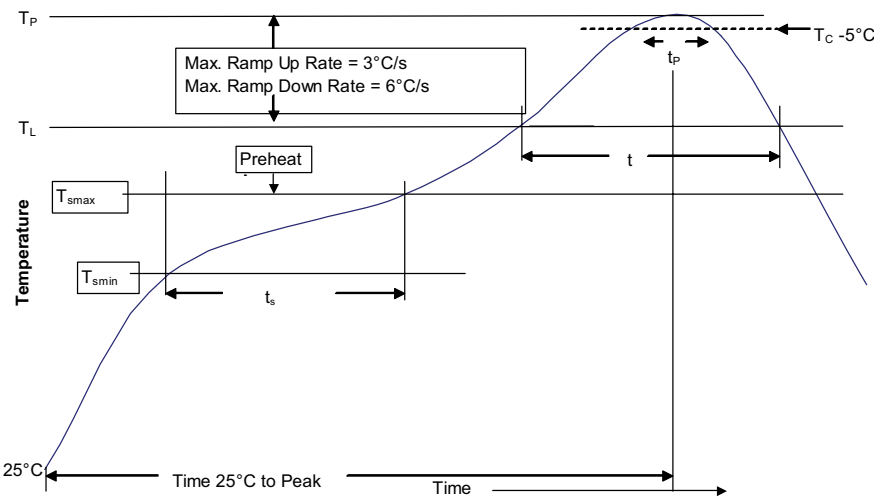

Table 1 - Standard SnPb solder (T_C)

Package thickness	Volume mm ³ <350	Volume mm ³ ≥350
<2.5 mm	235 °C	220 °C
≥2.5 mm	220 °C	220 °C

Table 2 - Lead (Pb) free solder (T_C)

Package thickness	Volume mm ³ <350	Volume mm ³ 350 - 2000	Volume mm ³ >2000
<1.6 mm	260 °C	260 °C	260 °C
1.6 – 2.5 mm	260 °C	250 °C	245 °C
>2.5 mm	250 °C	245 °C	245 °C

Reference J-STD-020

Profile feature	Standard SnPb solder	Lead (Pb) free solder
Preheat and soak	<ul style="list-style-type: none"> Temperature min. (T_{smin}) Temperature max. (T_{smax}) Time (T_{smin} to T_{smax}) (t_s) 	<ul style="list-style-type: none"> 100 °C 150 °C 60-120 seconds
Ramp up rate T _L to T _p	3 °C/ second max.	3 °C/ second max.
Liquidous temperature (T _L)	183 °C	217 °C
Time (t _L) maintained above T _L	60-150 seconds	60-150 seconds
Peak package body temperature (T _p)*	Table 1	Table 2
Time (t _p)* within 5 °C of the specified classification temperature (T _C)	20 seconds*	30 seconds*
Ramp-down rate (T _p to T _L)	6 °C/ second max.	6 °C/ second max.
Time 25 °C to peak temperature	6 minutes max.	8 minutes max.

* Tolerance for peak profile temperature (T_p) is defined as a supplier minimum and a user maximum.

Life Support Policy: Eaton does not authorize the use of any of its products for use in life support devices or systems without the express written approval of an officer of the Company. Life support systems are devices which support or sustain life, and whose failure to perform, when properly used in accordance with instructions for use provided in the labeling, can be reasonably expected to result in significant injury to the user.

Eaton reserves the right, without notice, to change design or construction of any products and to discontinue or limit distribution of any products. Eaton also reserves the right to change or update, without notice, any technical information contained in this bulletin.

Eaton
Electronics Division
 1000 Eaton Boulevard
 Cleveland, OH 44122
 United States
 Eaton.com/electronics

© 2022 Eaton
 All Rights Reserved
 Printed in USA
 Publication No. ELX1119
 March 2022

Eaton is a registered trademark.
 All other trademarks are property of their respective owners.

Follow us on social media to get the latest product and support information.

