

IGM205

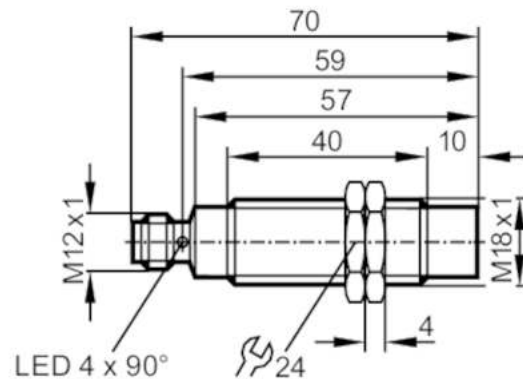

Inductive sensor

IGK3012-BPKG/M/60V/US-104-DPS



Product characteristics

Electrical design		PNP
Output function		normally open
Sensing range	[mm]	12
Housing		threaded type
Dimensions	[mm]	M18 x 1 / L = 70

Application

Special feature		Gold-plated contacts; Increased sensing range
Application		Use in mobile and harsh applications

Electrical data

Operating voltage	[V]	10...60 DC
Current consumption	[mA]	< 10
Protection class		II
Reverse polarity protection		yes

Outputs

Electrical design		PNP
Output function		normally open
Max. voltage drop switching output DC	[V]	2.5
Permanent current rating of switching output DC	[mA]	200
Switching frequency DC	[Hz]	200
Short-circuit protection		yes
Overload protection		yes

Detection zone

Sensing range	[mm]	12
Real sensing range Sr	[mm]	12 ± 10 %
Assured operating distance	[mm]	0...9.72
Increased sensing range		yes

IGM205



Inductive sensor

IGK3012-BPKG/M/60V/US-104-DPS

Accuracy / deviations			
Correction factor		steel: 1 / stainless steel: 0.7 / brass: 0.5 / aluminium: 0.45 / copper: 0.35	
Hysteresis	[% of Sr]	1...20	
Switch point drift	[% of Sr]	-10...10	
Operating conditions			
Ambient temperature	[°C]	-40...85	
Protection		IP 67; IP 69K	
Tests / approvals			
EMC	automotive area		
	noise emission and noise interference: ECE R10	E1 type approval	
	noise immunity according to DIN ISO 11452-2	100 V/m	
	conducted interference in 24 V networks to ISO 7637-2: 2004 (pulse 1 to 4) and ISO16750-2: 2012 (load dump)		
	pulse	1 2a 2b 3a 3b 4 Load dump	
	severity level	III III III III III III Test A	
	failure criterion	C A C A A C C	
	EN 61000-4-2 ESD	4 kV CD / 8 kV AD	
	EN 61000-4-3 HF radiated	10 V/m	
	EN 61000-4-4 Burst	2 kV	
	EN 61000-4-5 Surge	0,5 kV mains line to line	
	EN 61000-4-6 HF conducted	10 V	
	EN 55011	class B	
	Vibration resistance	EN 60068-2-6 Fc	20 g (10...3000 Hz) / -20...50 °C 50 sweep cycles, 1 octave per minute, in 3 axes
	Shock resistance	EN 60068-2-27 Ea	100 g 11 ms half-sine; 3 shocks each in every direction of the 3 coordinate axes / -40...85 °C
Continuous shock resistance	EN 60068-2-27	40 g 6 ms; 4000 shocks each in every direction of the 3 coordinate axes / -20...50 °C	
Fast temperature change	EN 60068-2-14 Na	TA = -40 °C; TB = 85 °C; t1 = 30 min; t2 = < 10 s; 50 cycles	
Salt spray test	EN 60068-2-52 Kb	severity level 5 (4 test cycles)	
MTTF	[years]	1112	
UL approval	Ta	0...40 °C	
	Enclosure type	Type 1	
	power supply	Hazardous voltage	
	File number UL	E174191	
Mechanical data			
Weight	[g]	53	
Housing		threaded type	
Mounting		non-flush mountable	
Dimensions	[mm]	M18 x 1 / L = 70	
Thread designation		M18 x 1	
Materials		housing: stainless steel; sensing face: LCP natural; LED window: PEI; lock nuts: brass white bronze coated	

IGM205



Inductive sensor

IGK3012-BPKG/M/60V/US-104-DPS

Tightening torque [Nm] 50

Displays / operating elements

Display switching status 4 x 90° LED, yellow

Accessories

Items supplied lock nuts: 2

Remarks

Pack quantity 1 pcs.

Electrical connection - plug

Connector: 1 x M12; coding: A; Contacts: gold-plated



Connection

