

**Level Translating I2C Bus/SMBus Repeater**

**Features**

- 2-channel, bidirectional buffer
- I<sup>2</sup>C-bus and SMBus compatible
- Port A operating supply voltage range of 0.8 V to 5.5 V
- Port B operating supply voltage range of 2.2 V to 5.5 V
- Voltage level translation from 0.8 V to 5.5 V and from 2.2 V to 5.5 V
- Active HIGH repeater enable input
- Open-drain input/outputs
- Lock-up free operation
- Supports arbitration and clock stretching across the repeater
- Accommodates Standard-mode and Fast-mode I<sup>2</sup>C-bus devices and multiple masters
- Powered-off high-impedance I<sup>2</sup>C-bus pins
- 5.5 V tolerant I<sup>2</sup>C-bus and enable pins
- 0 Hz to 400 kHz clock frequency (the maximum system operating frequency may be less than 400 kHz because of the delays added by the repeater)
- ESD protection exceeds 8KV HBM per JESD22-A114
- Totally Lead-Free & Fully RoHS Compliant (Notes 1 & 2)
- Halogen and Antimony Free. “Green” Device (Note 3)
- For automotive applications requiring specific change control (i.e. parts qualified to AEC-Q100/101/200, PPAP capable, and manufactured in IATF 16949 certified facilities), please [contact us](#) or your local Diodes representative.
- <https://www.diodes.com/quality/product-definitions/>
- Package:
  - MSOP-8 (U),
  - TDFN2x3-8 (ZE)
  - SOIC-8 (W) (Not Recommended for New Design)

**Description**

The PI6ULS5V9517A is a CMOS integrated circuit intended for I<sup>2</sup>C-bus or SMBus applications. The device can provide level shifting between a lower voltage (down to 0.8 V) and a higher voltage (2.2V to 5.5V) in mixed-mode applications. In addition, the device enables I<sup>2</sup>C and similar bus system to be extended, without performance degradation even during level shifting.

The PI6ULS5V9517A enables the system designer to isolate two halves of a bus in both voltage and capacitance, accommodating more I<sup>2</sup>C devices or longer trace length. The device also permits extension of the I<sup>2</sup>C-bus with bidirectional buffering for both the data (SDA) and the clock (SCL) lines, thus allowing two buses of 400 pF to be connected in an I<sup>2</sup>C application.

**Notes:**

1. No purposely added lead. Fully EU Directive 2002/95/EC (RoHS), 2011/65/EU (RoHS 2) & 2015/863/EU (RoHS 3) compliant.
2. See <https://www.diodes.com/quality/lead-free/> for more information about Diodes Incorporated's definitions of Halogen- and Antimony-free, "Green" and Lead-free.
3. Halogen- and Antimony-free "Green" products are defined as those which contain <900ppm bromine, <900ppm chlorine (<1500ppm total Br + Cl) and <1000ppm antimony compounds.
4. Automotive products are AEC-Q100 qualified and are PPAP capable. Refer to <https://www.diodes.com/quality/>.

## Pin Configuration

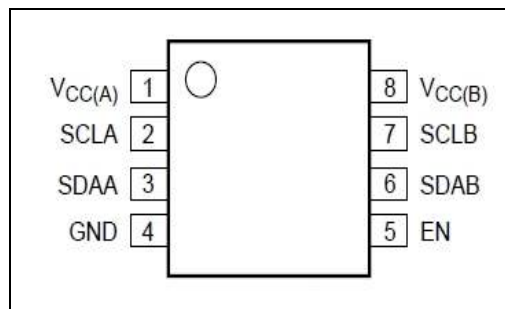

MSOP-8 and SOIC-8

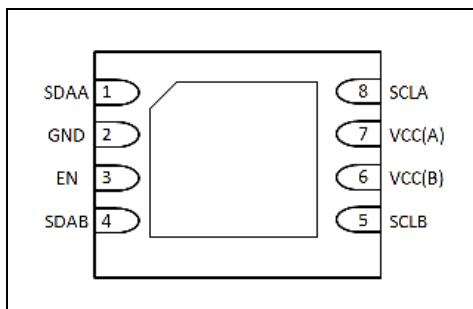

DFN2x3-8L(Top view)

## Pin Description

Pin #		Name	Description
MSOP-8 SOIC-8	DFN 2x3-8		
1	7	V <sub>CC(A)</sub>	port A supply voltage (0.8 to 5.5 V)
2	8	SCLA	serial clock port A bus
3	1	SDAA	serial data port A bus
4	2	GND <sup>(1)</sup>	supply ground (0 V)
5	3	EN	active HIGH repeater enable input
6	4	SDAB	serial data port B bus
7	5	SCLB	serial clock port B bus
8	6	V <sub>CC(B)</sub>	port B supply voltage (2.2 to 5.5 V)

Note:

DFN8 package die supply ground is connected to both GND pin and exposed center pad. GND pin must be connected to supply ground for proper device operation. For enhanced thermal, electrical, and board level performance, the exposed pad needs to be soldered to the board using a corresponding thermal pad on the board and for proper heat conduction through the board, thermal vias need to be incorporated in the PCB in the thermal pad region

**Block Diagram**

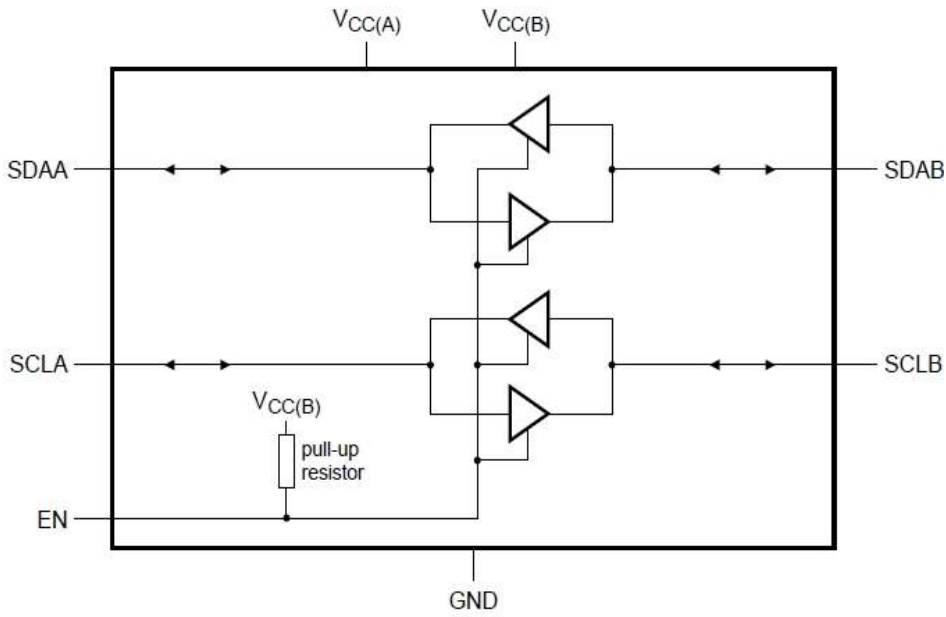

EN	Function
H	SCLA = SCLB; SDAA = SDAB;
L	disabled

Figure 1: Block Diagram

## Maximum Ratings

Storage Temperature.....	-55°C to +125°C
Supply Voltage port B.....	-0.5V to +6.0V
Supply Voltage port A.....	-0.5V to +6.0V
DC Input Voltage.....	-0.5V to +6.0V
Control Input Voltage (EN).....	-0.5V to +6.0V
Total Power Dissipation.....	100mA
Input/Output Current (portA&B).....	50mA
Input Current (EN, V <sub>CC(A)</sub> , V <sub>CC(B)</sub> , GND).....	50mA
ESD: HBM Mode.....	8000V

### Note:

Stresses greater than those listed under MAXIMUM RATINGS may cause permanent damage to the device. This is a stress rating only and functional operation of the device at these or any other conditions above those indicated in the operational sections of this specification is not implied. Exposure to absolute maximum rating conditions for extended periods may affect reliability.

## Recommended operation conditions

V<sub>CC</sub> = 2.2 V to 5.5 V; GND = 0 V; T<sub>amb</sub> = -40 °C to +85 °C; unless otherwise specified

Symbol	Parameter	Test Conditions	Min.	Typ.	Max.	Unit
V <sub>CC(B)</sub>	Supply voltage port B	-	2.2	-	5.5	V
V <sub>CC(A)</sub>	Supply voltage port A	-	0.8	-	5.5	V
I <sub>CC(A)</sub>	Supply current on pin V <sub>CC(A)</sub>	-	-	-	500	μA
ICCH	HIGH-level supply current	both channels HIGH; V <sub>CC</sub> = 5.5 V; SDA <sub>n</sub> = SCL <sub>n</sub> = V <sub>CC</sub>	-	0.5	2	mA
ICCL	LOW-level supply current	both channels LOW; V <sub>CC</sub> = 5.5 V; one SDA and one SCL = GND; other SDA and SCL open	-	0.5	2	mA
ICC(B) <sub>c</sub>	Contention port B supply current	V <sub>CC</sub> = 5.5 V; SDA <sub>n</sub> = SCL <sub>n</sub> = V <sub>CC</sub>	-	0.5	2	mA

**DC Electrical Characteristics**

 V<sub>CC</sub> = 2.2 V to 5.5 V; GND = 0 V; T<sub>amb</sub> = -40 °C to +85 °C; unless otherwise specified

Parameter	Description	Test Conditions <sup>(1)</sup>	Min.	Typ. <sup>(2)</sup>	Max.	Unit
<b>Input and output SDAB and SCLB</b>						
V <sub>IH</sub>	HIGH-level input voltage	-	0.7V <sub>CC(B)</sub>	-	5.5	V
V <sub>IL</sub> <sup>(1)</sup>	LOW-level input voltage	-	-0.5	-	+0.3V <sub>CC(B)</sub>	
V <sub>ILc</sub>	Contention LOW-level input voltage	-	-0.5	0.4	-	
V <sub>IK</sub>	Input clamping voltage	I <sub>I</sub> = -18 mA	-	-	-1.2	V
I <sub>LI</sub>	Input leakage current	V <sub>I</sub> = 3.6 V	-	-	±1	μA
I <sub>IL</sub>	LOW-level input current	SDA, SCL; V <sub>I</sub> = 0.2 V	-	10	-	μA
V <sub>OL</sub>	LOW-level output voltage	I <sub>OL</sub> = 100μA or 6 mA	0.47	0.52	0.6	V
V <sub>OL</sub> -V <sub>ILc</sub>	Difference between LOW-level output and LOW-level input voltage contention	guaranteed by design	-	70	-	mV
I <sub>LOH</sub>	HIGH-level output leakage current	V <sub>O</sub> = 3.6 V	-	-	10	μA
C <sub>io</sub>	Input/output capacitance	V <sub>I</sub> = 3 V or 0 V; V <sub>CC</sub> = 3.3 V V <sub>I</sub> = 3 V or 0 V; V <sub>CC</sub> = 0 V	-	6	-	pF
<b>Input and output SDAA and SCLA</b>						
V <sub>IH</sub>	HIGH-level input voltage	-	0.7V <sub>CC(A)</sub>	-	5.5	V
V <sub>IL</sub> <sup>(2)</sup>	LOW-level input voltage	-	-0.5	-	+0.25V <sub>CC(A)</sub>	
V <sub>IK</sub>	Input clamping voltage	I <sub>I</sub> = -18 mA	-	-	-1.2	V
I <sub>LI</sub>	Input leakage current	V <sub>I</sub> = 3.6 V	-	-	±1	μA
I <sub>IL</sub>	LOW-level input current	SDA, SCL; V <sub>I</sub> = 0.2 V	-	-	10	μA
V <sub>OL</sub>	LOW-level output voltage	I <sub>OL</sub> = 6 mA	-	0.1	0.2	V
I <sub>LOH</sub>	HIGH-level output leakage current	V <sub>O</sub> = 3.6 V	-	-	10	μA
C <sub>io</sub>	Input/output capacitance	V <sub>I</sub> = 3 V or 0 V; V <sub>CC</sub> = 3.3 V V <sub>I</sub> = 3 V or 0 V; V <sub>CC</sub> = 0 V	-	6	-	pF
<b>Enable</b>						
V <sub>IH</sub>	HIGH-level input voltage	-	0.7V <sub>cc(B)</sub>	-	5.5	V
V <sub>IL</sub>	LOW-level input voltage	-	-0.5	-	+0.3V <sub>cc(B)</sub>	V
I <sub>IL</sub>	LOW-level input current	V <sub>I</sub> = 0.2 V, EN; V <sub>CC</sub> = 3.6 V	-	-10	-30	μA
I <sub>LI</sub>	Input leakage current	V <sub>I</sub> = V <sub>cc(B)</sub>	-1	-	+1	μA
C <sub>i</sub>	Input capacitance	V <sub>I</sub> = 3.0 V or 0 V	-	6	-	pF

**Notes:**

- V<sub>IL</sub> specification is for the first LOW level seen by the SDAB/SCLB lines. V<sub>ILc</sub> is for the second and subsequent LOW levels seen by the SDAB/SCLB lines.
- V<sub>IL</sub> for port A with envelope noise must be below 0.3V<sub>CC(A)</sub> for stable performance.

### Dynamic Characteristics

$V_{CC} = 2.2\text{ V to } 5.5\text{ V}$ ;  $GND = 0\text{ V}$ ;  $T_{amb} = -40\text{ }^{\circ}\text{C to } +85\text{ }^{\circ}\text{C}$ ; unless otherwise specified. <sup>(1)(2)</sup>

Symbol	Parameter	Test Conditions	Min.	Typ.	Max.	Unit
$t_{PLH}$	LOW-to-HIGH propagation delay	B-side to A-side	-	169	255	ns
$t_{PHL}$	HIGH-to-LOW propagation delay	B-side to A-side, $V_{CC(A)} \leq 2.7\text{ V}$	15	68	110	ns
		B-side to A-side, $V_{CC(A)} \geq 3\text{ V}$	10	103	300	ns
$t_{TLH}$	LOW-to-HIGH transition time	A-side	-	50	60	ns
$t_{THL}$	HIGH-to-LOW transition time	A-side, $V_{CC(A)} \leq 2.7\text{ V}$	1	3	105	ns
		A-side, $V_{CC(A)} \geq 3\text{ V}$	1	25	175	ns
$t_{PLH}$	LOW-to-HIGH propagation delay	A-side to B-side	25	67	110	ns
$t_{PHL}$	HIGH-to-LOW propagation delay	A-side to B-side	-	118	230	ns
$t_{TLH}$	LOW-to-HIGH transition time	B-side	-	140	170	ns
$t_{THL}$	HIGH-to-LOW transition time	B-side	-	40	105	ns
$t_{SU}$	Set-up time	EN HIGH before START condition	100	-	-	ns
$t_H$	Hold time	EN HIGH after STOP condition	100	-	-	ns

**Notes:**

1. Times are specified with loads of 1.35kΩ pull-up resistance and 57 pF load capacitance on port B, and 167Ω pull-up resistance and 57 pF load capacitance on port A. Different load resistance and capacitance will alter the RC time constant, thereby changing the propagation delay and transition times.
2. Pull-up voltages are  $V_{CC(A)}$  on port A and  $V_{CC(B)}$  on port B.
3. Typical values were measured with  $V_{CC(A)} = 3.3\text{ V}$  at  $T_{amb} = 25^{\circ}\text{C}$ , unless otherwise noted.

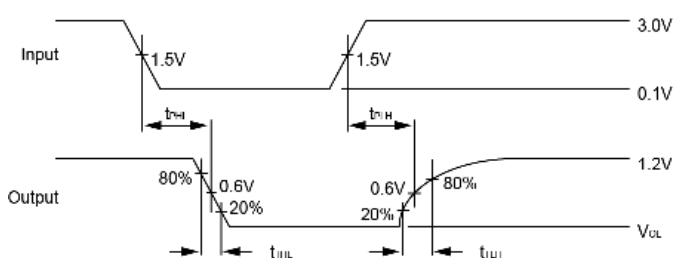

Figure 2: Propagation Delay and Transition Times B→A

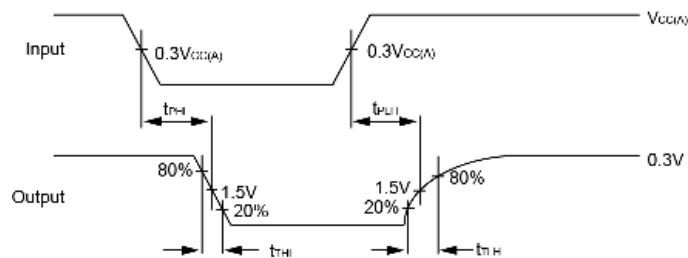

Figure 3: Propagation Delay and Transition Times A→B

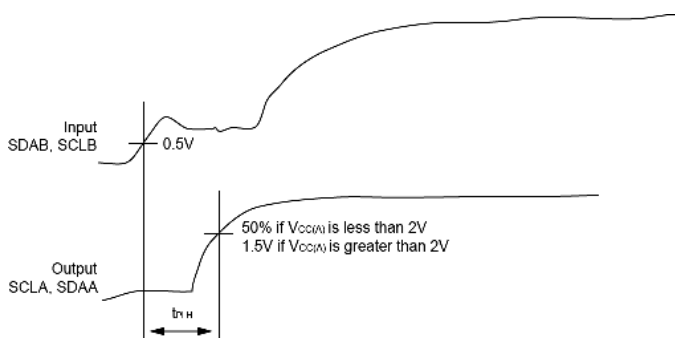
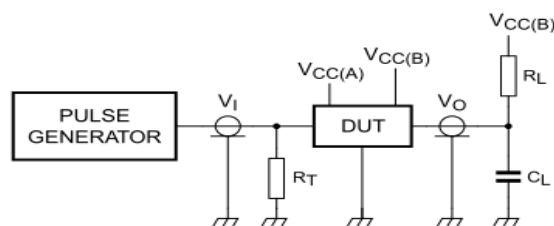

Figure 4: Propagation Delay



$R_L$  = Load resistor: 1.35kΩ on port B; 167Ω on port A (0.8V to 2.7V) and 450Ω on port A (3.0V to 5.5V)  
 $C_L$  = Load capacitance includes jig and probe capacitance: 57pF  
 $R_T$  = Termination resistance should be equal to Z of pulse generators

Figure 5: Test Circuit

## Functional Description

The PI6ULS5V9517A is a CMOS integrated circuit intended for I<sup>2</sup>C-bus or SMBus applications. It can provide level shifting between low voltage (down to 0.8 V) and higher voltage (2.2 V to 5.5 V) in mixed-mode applications. And it enables I<sup>2</sup>C and similar bus system to be extended, without degradation of performance even during level shifting.

The PI6ULS5V9517A enables the system designer to isolate two halves of a bus for both voltage and capacitance, accommodating more I2C devices or longer trace length. It also permits extension of the I<sup>2</sup>C-bus by providing bidirectional buffering for both the data (SDA) and the clock (SCL) lines, thus allowing two buses of 400 pF to be connected in an I<sup>2</sup>C application.

The B-side drivers operate from 2.2 V to 5.5 V. The output low level of port B internal buffer is approximately 0.5 V, while the input voltage must be 70mV lower (0.43V) or even more lower. The nearly 0.5V low signal is called a buffered low. When the B-side I/O is driven low internally, the low is not recognized as a low by the input. This feature prevents a lockup condition from occurring when the input low condition is released. This type of design on B port prevents it from being used in series with another PI6ULS5V9517A (B side) or similar devices, because they don't recognize buffer low signals as a valid low.

The A-side drivers operate from 0.8 V to 5.5 V. The output low level of port A internal buffer is nearly 0V, while the input low level is set at 0.3V<sub>cc(A)</sub> to accommodate the need for a lower LOW level in systems where the low voltage side supply voltage is as low as 0.8 V. Port A of two or more PI6ULS5V9517As can be connected together to allow a star topography with port A on the common bus. And port A can be connected directly to any other buffer with static or dynamic offset voltage. Multiple PI6ULS5V9517As can be connected in series, port A to port B, with no build-up in offset voltage with only time off light delays to consider.

The EN pin can also be used to turn the drivers on and off. This can be used to isolate a badly behaved slave on power-up until after the system power-up reset. It should never change state during an I<sup>2</sup>C-bus operation because disabling during a bus operation will hang the bus and enabling part way through a bus cycle could confuse the I<sup>2</sup>C-bus parts being enabled. The enable pin should only change state when the global bus and the repeater port are in an idle state to prevent system failures.

After power-up and with the EN HIGH, a LOW level on port A (below 0.3V<sub>cc(A)</sub>) turns the corresponding port B driver (either SDA or SCL) on and drives port B down to about 0.5 V. When port A rises above 0.3V<sub>cc(A)</sub>, the port B pull-down driver is turned off and the external pull-up resistor pulls the pin HIGH. When port B falls first and goes below 0.3V<sub>cc(B)</sub> the port A driver is turned on and port A pulls down to 0 V. The port B pull-down is not enabled unless the port B voltage goes below 0.4 V. If the port B low voltage does not go below 0.5 V, the port A driver will turn off when port B voltage is above 0.7V<sub>cc(B)</sub>. If the port B low voltage goes below 0.4 V, the port B pull-down driver is enabled and port B will only be able to rise to 0.5 V until port A rises above 0.3V<sub>cc(A)</sub>. Then port B will continue to rise being pulled up by the external pull-up resistor. The V<sub>cc(A)</sub> is only used to provide the 0.3V<sub>cc(A)</sub> reference to the port A input comparators and for the power good detect circuit. The PI6ULS5V9517A logic and all I/Os are powered by the V<sub>cc(B)</sub> pin.

The EN pin is active high and allows the user to select when the repeater is active. This can be used to isolate a badly behaved slave on power-up until after the system power-up reset. It should never change state during an I<sup>2</sup>C-bus operation because disabling during a bus operation will hang the bus and enabling part way through a bus cycle could confuse the I<sup>2</sup>C-bus parts being enabled. The enable pin should only change state when the global bus and the repeater port are in an idle state to prevent system failures.

As with the standard I<sup>2</sup>C system, pullup resistors are required to provide the logic-high levels on the buffered bus. The PI6ULS5V9517A has standard open-collector configuration of the I<sup>2</sup>C bus. The size of these pullup resistors depends on the system, but each side of the repeater must have a pullup resistor. The device is designed to work with Standard mode and Fast mode I<sup>2</sup>C devices in addition to SMBus devices. Standard mode I<sup>2</sup>C devices only specify 3 mA in a generic I<sup>2</sup>C system, where Standard mode devices and multiple masters are possible. Under certain conditions, higher termination currents can be used.

## Application Information

A typical application is shown in Figure 6. In this example, the system master is running on a 3.3 V I<sup>2</sup>C-bus while the slave is connected to a 1.2 V bus. Both buses run at 400 kHz. Master devices can be placed on either bus.

The PI6ULS5V9517A is 5V tolerant, so it does not require any additional circuitry to translate between 0.8V to 5.5V bus voltages and 2.2V to 5.5V bus voltages.

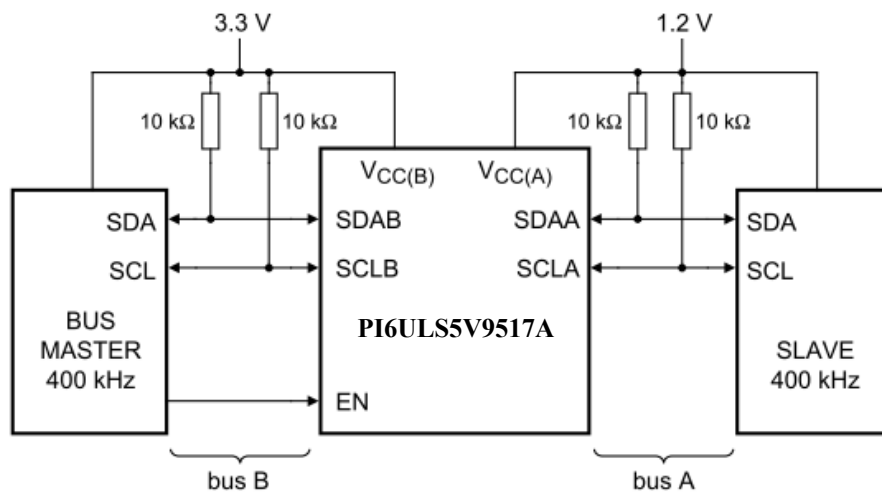

Figure 6: Typical Application

When port A of the PI6ULS5V9517A is pulled LOW by a driver on the I<sup>2</sup>C-bus, a comparator detects the falling edge when it goes below 0.3 V<sub>CC(A)</sub> and causes the internal driver on port B to turn on, causing port B to pull down to about 0.5 V. When port B of the PI6ULS5V9517A falls, first a CMOS hysteresis type input detects the falling edge and causes the internal driver on port A to turn on and pull the port A pin down to ground. In order to illustrate what would be seen in a typical application, refer to Figure 9 and Figure 10. If the bus master in Figure 6 were to write to the slave through the PI6ULS5V9517A, waveforms shown in Figure 9 would be observed on the A bus. This looks like a normal I<sup>2</sup>C-bus transmission except that the HIGH level may be as low as 0.8V, and the turn on and turn off of the acknowledge signals are slightly delayed.

On the B-side bus of the PI6ULS5V9517A, the clock and data lines would have a positive offset from ground equal to the VOL of the PI6ULS5V9517A. After the eighth clock pulse, the data line is pulled to the VOL of the slave device, which is very close to ground in this example. At the end of the acknowledge, the level rises only to the low level set by the driver in the PI6ULS5V9517A for a short delay, while the A-bus side rises above 0.3 V<sub>CC(A)</sub> and then it continues high.

Multiple PI6ULS5V9517A port A sides can be connected in a star configuration (Figure 7), allowing all nodes to communicate with each other.

Multiple PI6ULS5V9517As can be connected in series (Figure 8) as long as port A is connected to port B. I<sup>2</sup>C-bus slave devices can be connected to any of the bus segments. The number of devices that can be connected in series is limited by repeater delay/time-of-flight considerations on the maximum bus speed requirements.



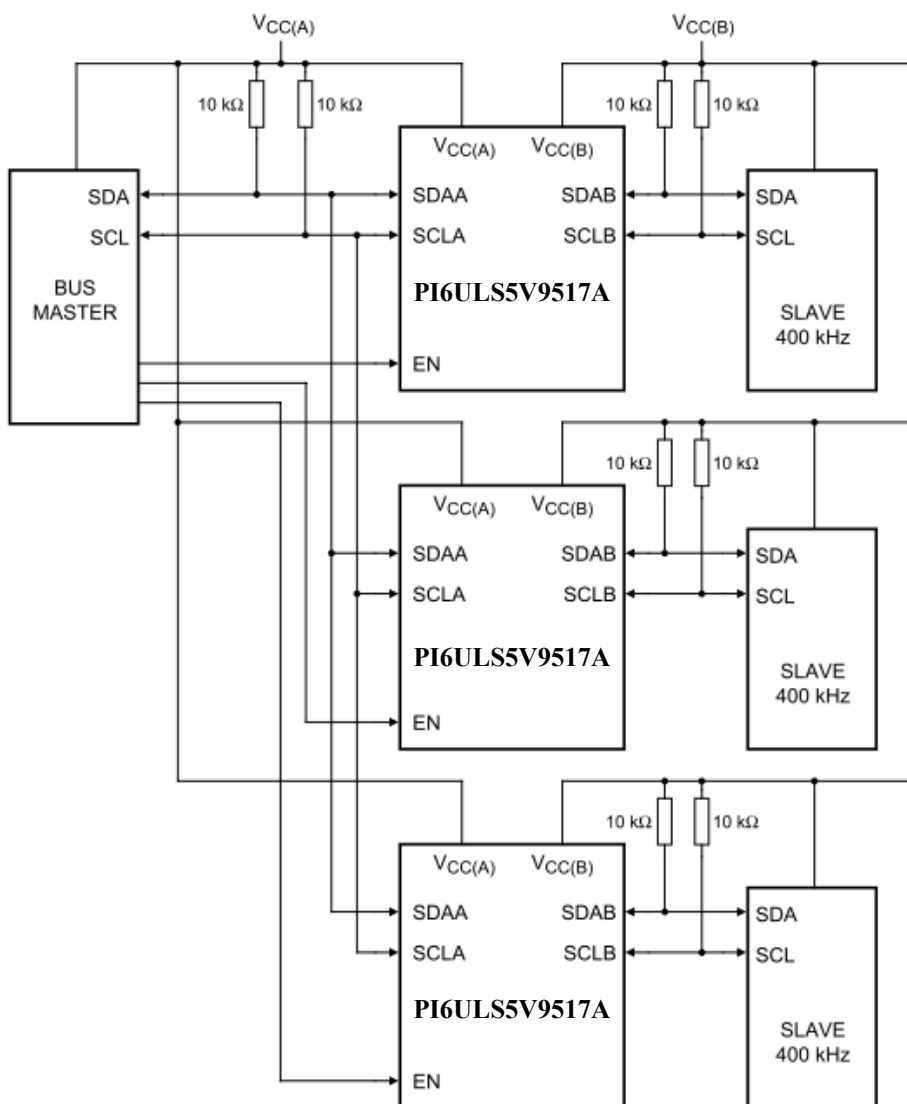

Figure 7: Typical Star Application

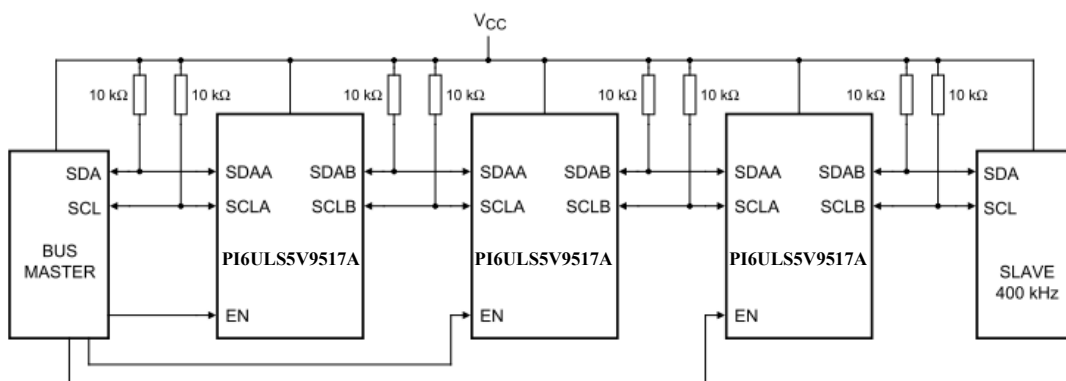

Figure 8: Typical Series Application

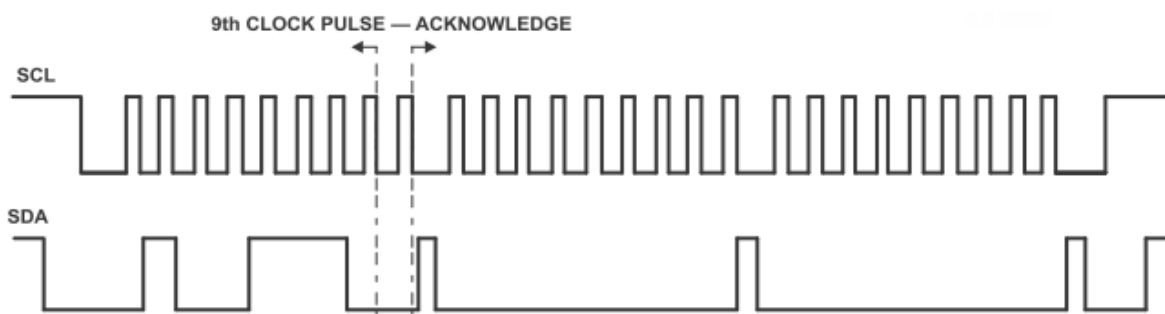

Figure 9: Bus A (0.8V to 5.5V Bus) Waveform

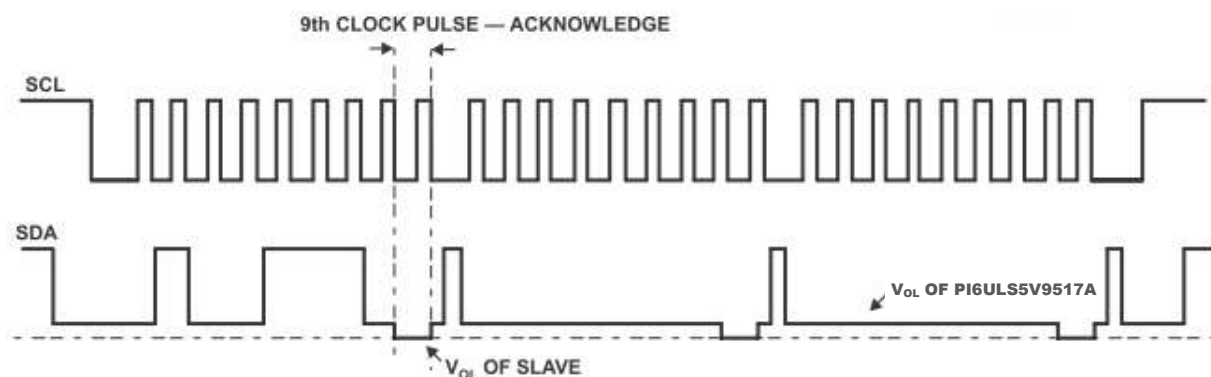
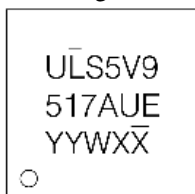

Figure 10: Bus B (2.2V to 5.5V Bus) Waveform

**Part Marking**

**U Package**



1st Y: Die Rev  
2nd Y: Year  
W: Workweek  
1st X: Assembly Site Code  
2nd X: Fab Site Code  
Bar above "L" means Fab3 of MGN

**ZE Package**

rV = PI6ULS5V9517AZEE

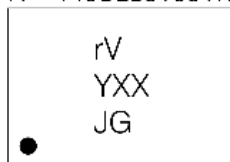

Y: Die Rev  
XX: Date Code (Year & Workweek)  
J: Assembly Site Code  
G: Fab Site Code  
Bar above "V" means Fab3 of MGN

**W Package**

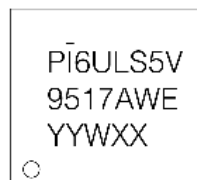

1st Y: Die Rev  
2nd Y: Year  
W: Workweek  
1st X: Assembly Site Code  
2nd X: Fab Site Code  
Bar above "I" means Fab3 of MGN

## Packaging Mechanical

MSOP-8 (U)

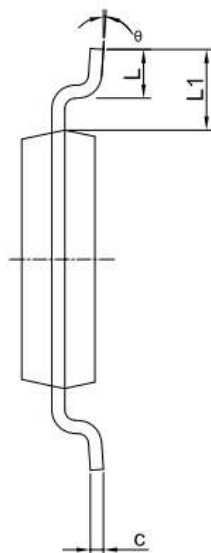
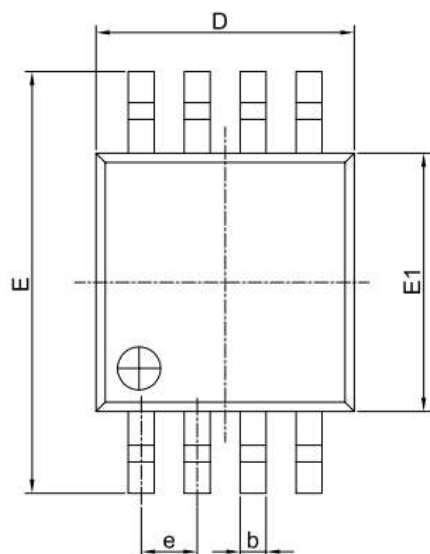

PKG DIMENSIONS(MM)		
SYMBOL	Min.	Max.
A	-	1.10
A1	0.00	0.15
A2	0.75	0.95
b	0.22	0.38
c	0.08	0.23
D	2.80	3.20
E	4.65	5.15
E1	2.80	3.20
e	0.65 BSC	
L	0.40	0.80
L1	0.95 REF	
theta	0°	8°

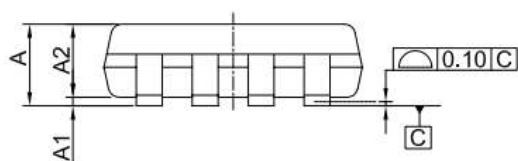

**NOTE:**

1. ALL DIMENSIONS ARE IN MILLIMETERS. ANGLES IN DEGREES.
2. REFER JEDEC MO-187F/AA
3. PACKAGE OUTLINE DIMENSIONS DO NOT INCLUDE MOLD FLASH AND METAL BURR.

		DATE: 11/03/16
DESCRIPTION: 8-Pin, MInI Small Outline Package, MSOP		
PACKAGE CODE: U (U8)		
DOCUMENT CONTROL #: PD-1261	REVISION: G	

**TDFN-8 (ZE)**

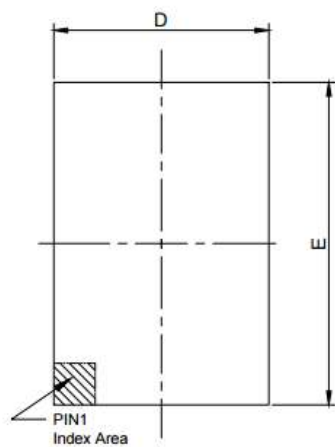

TOP VIEW

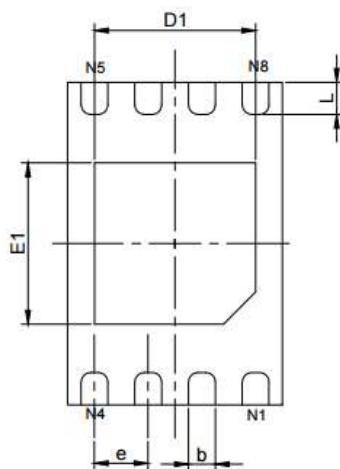

BOTTOM VIEW

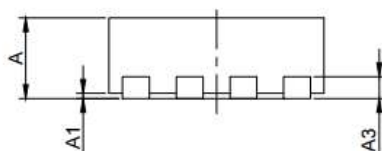

SIDE VIEW

PKG. DIMENSIONS(MM)		
SYMBOL	Min	Max
A	0.70	0.80
A1	0.00	0.05
A3	0.20 REF	
D	1.92	2.08
E	2.92	3.07
D1	1.40	1.60
E1	1.40	1.60
k	0.20 MIN	
b	0.20	0.30
e	0.50 TYP	
L	0.22	0.38

**Notes:**

1. Ref: JEDEC MO-229



DATE: 06/14/13

DESCRIPTION: 8-Pin, TDFN, 2X3

PACKAGE CODE: ZE (ZE8)

DOCUMENT CONTROL#: PD-2116

REVISION: --

**Recommended Land Pattern for TDFN2\*3-8L**

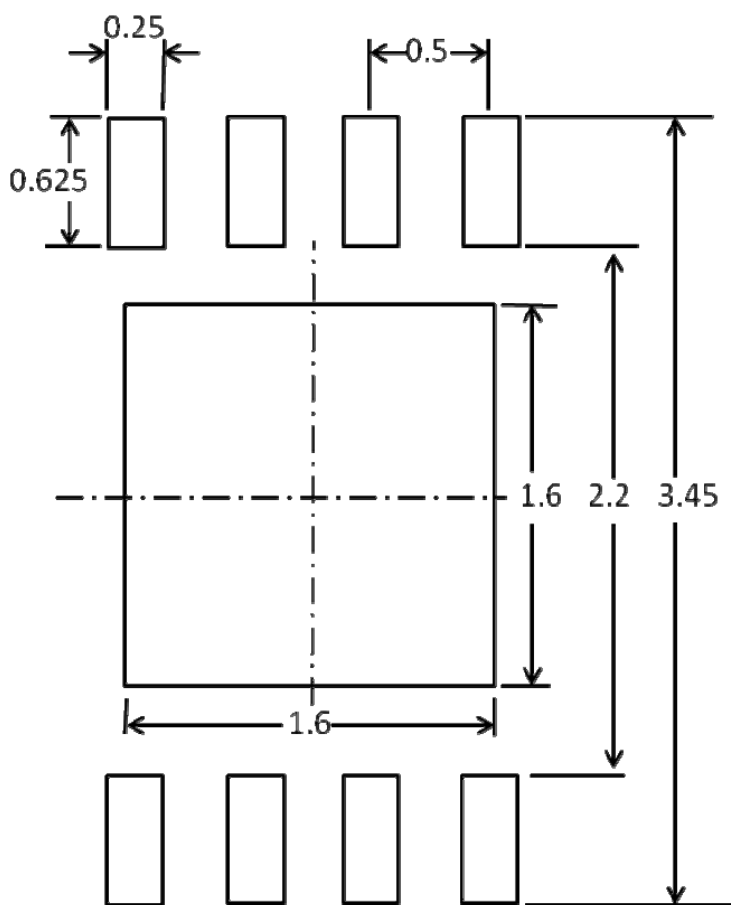

Note:  
All linear dimensions are in millimeters

**SOIC-8 (W)**

SYMBOLS	MIN.	NOM.	MAX.
A	—	—	1.75
A1	0.10	—	0.25
A2	1.25	—	—
b	0.31	—	0.51
c	0.10	—	0.25
D	4.80	4.90	5.00
E	5.80	6.00	6.20
E1	3.80	3.90	4.00
e	1.27 BSC		
L	0.40	—	1.27
h	0.25	—	0.50
θ°	0	—	8

UNIT : mm

**NOTE :**  
 1. ALL DIMENSIONS ARE IN mm. ANGLES IN DEGREES  
 2. DIMENSIONS EXCLUDE BURRS, MOLD FLASH OR PROTRUSIONS  
 3. REFER JEDEC MS-012

<b>PERICOM</b> Enabling Social Connectivity	DATE: 02/21/14
DESCRIPTION: 8-Pin, 150mil-Wide, SOIC	
PACKAGE CODE: W (W8)	
DOCUMENT CONTROL #: PD-1001	REVISION: G

For latest package info.

please check: <http://www.diodes.com/design/support/packaging/pericom-packaging/packaging-mechanicals-and-thermal-characteristics/>

**Ordering Information**

Part Numbers	Package Code	Package Description
PI6ULS5V9517AUEX	U	8-pin, Mini Small Outline Package (MSOP)
PI6ULS5V9517AZEEX	ZE	8-pin, 2x3 (TDFN)
PI6ULS5V9517AWEX	W	8-pin, 150mil-Wide (SOIC) (Not Recommend for New Design)

**Notes:**

- No purposely added lead. Fully EU Directive 2002/95/EC (RoHS), 2011/65/EU (RoHS 2) & 2015/863/EU (RoHS 3) compliant.
- See <https://www.diodes.com/quality/lead-free/> for more information about Diodes Incorporated's definitions of Halogen- and Antimony-free, "Green" and Lead-free.
- Halogen- and Antimony-free "Green" products are defined as those which contain <900ppm bromine, <900ppm chlorine (<1500ppm total Br + Cl) and <1000ppm antimony compounds.
- E = Pb-free and Green
- X suffix = Tape/Reel

**IMPORTANT NOTICE**

DIODES INCORPORATED MAKES NO WARRANTY OF ANY KIND, EXPRESS OR IMPLIED, WITH REGARDS TO THIS DOCUMENT, INCLUDING, BUT NOT LIMITED TO, THE IMPLIED WARRANTIES OF MERCHANTABILITY AND FITNESS FOR A PARTICULAR PURPOSE (AND THEIR EQUIVALENTS UNDER THE LAWS OF ANY JURISDICTION).

Diodes Incorporated and its subsidiaries reserve the right to make modifications, enhancements, improvements, corrections or other changes without further notice to this document and any product described herein. Diodes Incorporated does not assume any liability arising out of the application or use of this document or any product described herein; neither does Diodes Incorporated convey any license under its patent or trademark rights, nor the rights of others. Any Customer or user of this document or products described herein in such applications shall assume all risks of such use and will agree to hold Diodes Incorporated and all the companies whose products are represented on Diodes Incorporated website, harmless against all damages.

Diodes Incorporated does not warrant or accept any liability whatsoever in respect of any products purchased through unauthorized sales channel.

Should Customers purchase or use Diodes Incorporated products for any unintended or unauthorized application, Customers shall indemnify and hold Diodes Incorporated and its representatives harmless against all claims, damages, expenses, and attorney fees arising out of, directly or indirectly, any claim of personal injury or death associated with such unintended or unauthorized application.

Products described herein may be covered by one or more United States, international or foreign patents pending. Product names and markings noted herein may also be covered by one or more United States, international or foreign trademarks.

This document is written in English but may be translated into multiple languages for reference. Only the English version of this document is the final and determinative format released by Diodes Incorporated.

**LIFE SUPPORT**

Diodes Incorporated products are specifically not authorized for use as critical components in life support devices or systems without the express written approval of the Chief Executive Officer of Diodes Incorporated. As used herein:

A. Life support devices or systems are devices or systems which:

1. are intended to implant into the body, or
2. support or sustain life and whose failure to perform when properly used in accordance with instructions for use provided in the labeling can be reasonably expected to result in significant injury to the user.

B. A critical component is any component in a life support device or system whose failure to perform can be reasonably expected to cause the failure of the life support device or to affect its safety or effectiveness.

Customers represent that they have all necessary expertise in the safety and regulatory ramifications of their life support devices or systems, and acknowledge and agree that they are solely responsible for all legal, regulatory and safety-related requirements concerning their products and any use of Diodes Incorporated products in such safety-critical, life support devices or systems, notwithstanding any devices- or systems-related information or support that may be provided by Diodes Incorporated. Further, Customers must fully indemnify Diodes Incorporated and its representatives against any damages arising out of the use of Diodes Incorporated products in such safety-critical, life support devices or systems.

Copyright © 2020, Diodes Incorporated  
[www.diodes.com](http://www.diodes.com)