



# HAKKO 851

SMD REWORK STATION

SMD REWORK SYSTEM

No.851-2

## Instruction Manual

Thank you for purchasing the HAKKO 851  
SMD REWORK STATION.

Please read this manual before operating the HAKKO 851.  
Keep this manual readily accessible for reference.

### TABLE OF CONTENTS

1. PACKING LIST .....	1
2. SPECIFICATIONS .....	1
3. WARNINGS, CAUTIONS AND NOTES .....	2
4. PART NAMES & DESCRIPTIONS .....	3
5. USING THE HAKKO 851 (Preparation) .....	4
(Desoldering parts) .....	5
(Soldering parts) .....	6
6. REPLACING THE HEATING ELEMENT .....	6 - 8
7. PARTS LIST(Station) .....	9 •10
(Iron) .....	11•12
8. TEMPERATURE DISTRIBUTION CHARTS ....	13•14

# 1. PACKING LIST

Please check to make sure that all the items listed below are included in the HAKKO 851 package.

Station/Iron .....	1	Nozzle $\phi$ 1.5mm(0.06 in.) .....	1
Holder part .....	1	Nozzle $\phi$ 3.0mm(0.12 in.) .....	1
Nozzle holder .....	1	Instruction manual .....	1

# 2. SPECIFICATIONS

Name	HAKKO 851
Power consumption	85W

## ●Station

Power consumption	5W
Pump	Diaphragm type
Capacity	6 l/min. (max.)
Fuse	2A
Dimension	167(W) × 101(H) × 182(D)mm (6.6 × 4.0 × 7.1 in.)

## ●Soldering iron

Power consumption	80W
Heating element	Ceramic heater, 80W
Standard nozzle Inner dia.	$\phi$ 2.0mm (0.08 in.) Part No.A1066
Hot air blow temperature	100 - 540°C (212 - 1004°F)
Length	217mm (8.5 in.) w/o Silicone hose

## ●Optional /replacemnt parts

	Part No.	Part Names	Specifications
Heating element	A1068	Heating element	120V-80W, Ceramic
Nozzle	A1065	Nozzle	$\phi$ 1.5mm(0.06 in.) w/o nut
	A1066	Nozzle	$\phi$ 2.0mm(0.08 in.) w/o nut
	A1067	Nozzle	$\phi$ 3.0mm(0.12 in.) w/o nut
	A1147	Nozzle	$\phi$ 1.0mm(0.04 in.) w/o nut

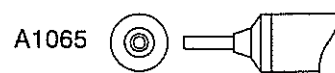

A1065  
Inner dia. : 1.5mm (0.06 in.)

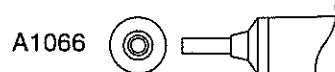

A1066  
Inner dia. : 2.0mm (0.08 in.)



A1067  
Inner dia. : 3.0mm (0.12 in.)

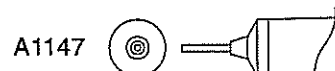

A1147  
Inner dia. : 1.0mm (0.04 in.)

\* This product is protected against electrostatic discharge.  
\* Specifications and design are subject to change without notice.

# 3. WARNINGS, CAUTIONS AND NOTES

## ⚠ WARNING

Warnings and cautions are placed at critical points in this manual to direct the operator's attention to significant items. They are defined as follows:

- ⚠ **WARNING:** Failure to comply with a WARNING may result in serious injury or death.
- ⚠ **CAUTION:** Failure to comply with a CAUTION may result in injury to the operator, or damage to the items involved.

## ⚠ CAUTION

### ● Observe the following precautions to ensure safety.

When the power is turned on, the nozzle temperature reaches 100 to 540°C (212 to 1004°F). If the unit is mishandled, **burn injury** or fire may result. Please observe the following precautions.

- Do not touch the metal portions surrounding the nozzle, the adjoining plastic portions, or the iron receptacle or iron receptacle holder of the iron holder.
- Do not use the product near flammable items.
- Do not direct the hot air toward personnel or touch the metal parts near the nozzle.
- Inform others in the area that the unit is hot and should not be touched.
- Turn the power off when not in use, or left unattended.
- Before replacing parts or storing the unit, turn off the power and allow the unit to cool to room temperature.

### ● Observe the following precautions to avoid accidents and damage to the unit.

- Do not strike the handpiece against hard surfaces or otherwise subject it to physical shock. This will damage the quartz glass shield around the heating element, and could damage the heater as well.
- Be sure the unit is grounded. Always connect power to a grounded receptacle.
- Do not disassemble the pump.
- Do not modify the unit.
- Use only genuine Hakko replacement parts.
- Do not wet the unit or use the unit when your hands are wet.
- Remove power cord by holding the plug - not the wires.
- Make sure the work area is well ventilated.
- Do not do anything else that might be dangerous.

## 4. PART NAMES & DESCRIPTIONS

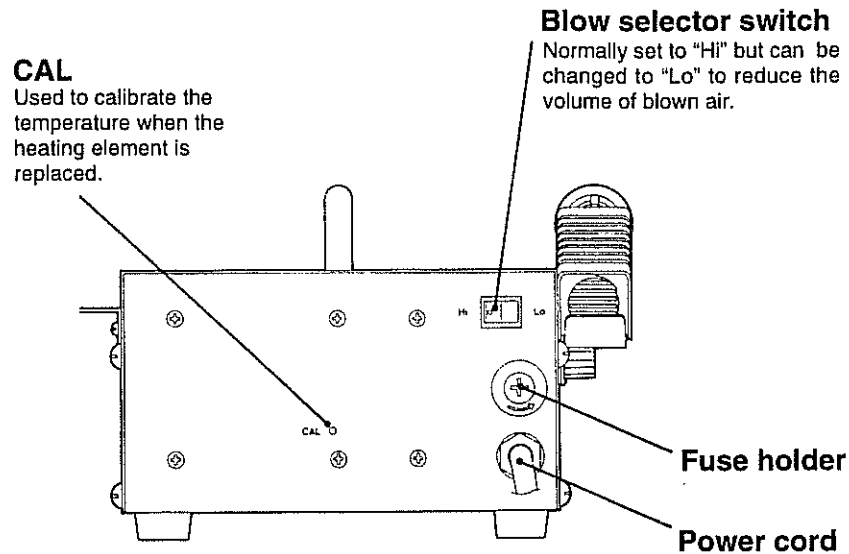
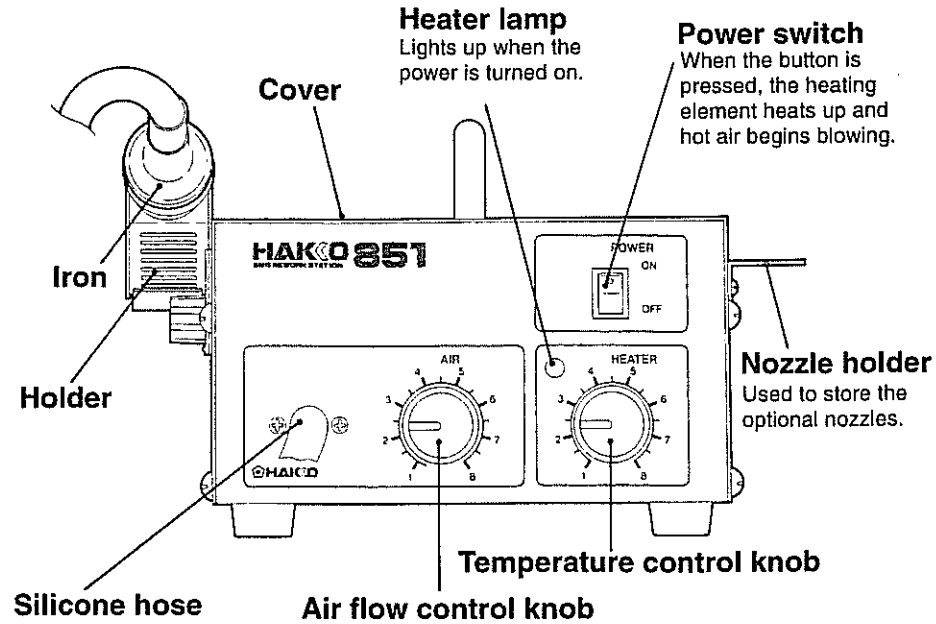

## 5. USING THE HAKKO 851 (Preparation)

1. Attach the holder
2. Insert iron into the holder
3. Insert power plug into outlet
  - Check to make sure the power switch is set to the OFF position before inserting the power plug.
4. Adjust blow level and temperature
 

Refer to the temperature distribution charts (p9) and adjust the blow level and temperature using the air flow and temperature control knob.
5. Turn on power
 

When the power switch is turned on, the heater power lamp will light up.
6. The unit is ready for use approximately two (2) minutes after the power is turned on

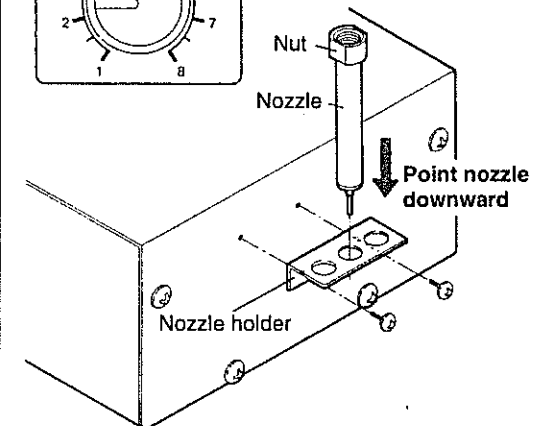
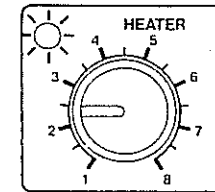
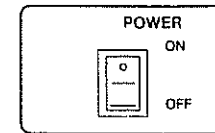
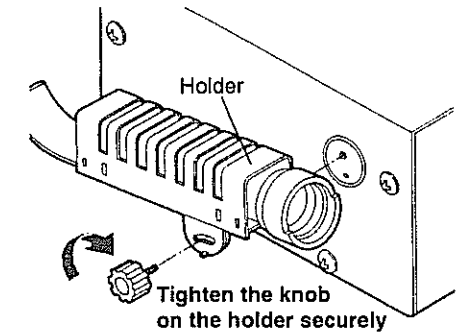

### Attaching and using the nozzle holder:

Attach the nozzle shelf included with the unit. With the nuts on the nozzles, insert them into the holes in nozzle holder with the tips facing downward, as shown in the figure above.

## 5. USING THE HAKKO 851 (Desoldering parts)

The unit can be used approximately two (2) minutes after the power has been turned on.

### 1. Heat the part

Apply the hot air to the part that is to be removed in order to melt the solder.

#### ⚠ CAUTION:

Be careful not to touch the component, etc. with the tip of the nozzle.

The blow selector switch on the rear of the unit should normally be set to "Hi". To reduce the blow level, set it to "Lo".

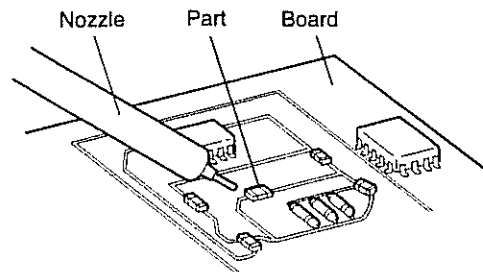

### 2. Grasp the part, using tweezers

While heating the part, use tweezers to grasp the part to be removed.

When grasping the part, do so by straddling the sides that are not soldered. This will help prevent the heat from dissipating.

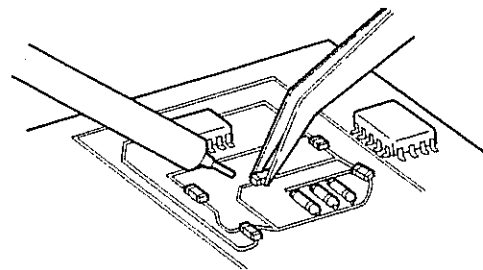

Using tweezers, grasp the unsoldered sides of the part

### 3. Remove the part

When the solder has melted, raise the tweezers to remove the part.

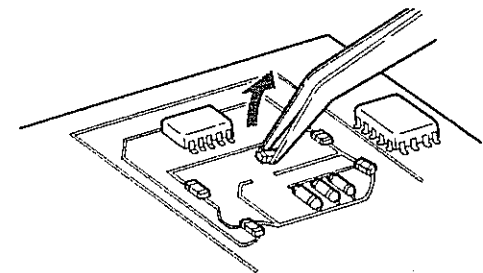

### 4. Remove any remaining solder

After the part has been removed, remove the old solder with desoldering wire or other solder removal tool.

## 5. USING THE HAKKO 851 (Soldering parts)

### 1. Coat with solder paste

Coat with a suitable amount of solder paste and mount the part.

### 2. Preheat the part

### 3. Solder the part

Apply the hot air to the section to be soldered and solder it in place.

#### ⚠ CAUTION:

If the blow level is too great, the part or the solder may be blown out of place. Reduce the blow level when soldering parts.

#### ⚠ CAUTION:

Soldering using hot air has many advantages, but it sometimes results in inadequate soldering. We recommend that all of the conditions for soldering be studied carefully.

## 6. REPLACING THE HEATING ELEMENT

### 1. Disassemble the air nozzle

- Remove the cover from the unit.
- Loosen the packing retainer on the rear of the panel.

### 2. Disassemble the iron

- Remove the nut, nozzle and nipple in that order.
- Slide the tube off of the terminal in the direction indicated by the arrow, then detach the grounding spring from the sleeve.

### 3. Pull out the heating element

- Pull the silicone hose so it is straight and then pull out the heating element from the handle, along with each of the cords.

#### ⚠ CAUTION:

When the cords are caught inside the silicone hose and do not move freely, press down on it lightly from above.

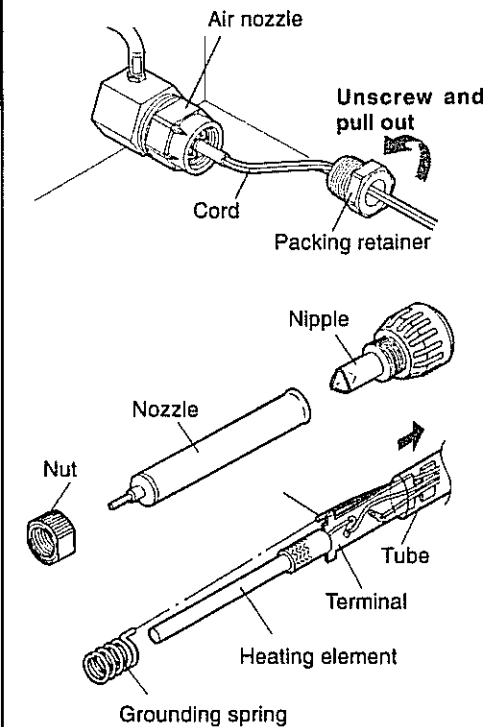

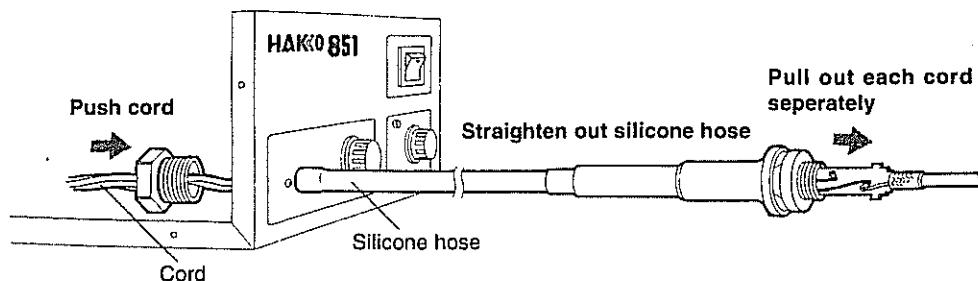

#### 4. Replace heating element

- Using a stripper or other desoldering tool, remove the solder from the soldered section of the terminal, then remove the old heating element.
- Set the new heating element in place as shown in the figures at right.
- Solder the lead wire of the heating element to the terminal.

Confirm that the distance between the tip of the heating element and the terminal is 82 - 84mm (3.2 in. - 3.3 in.).

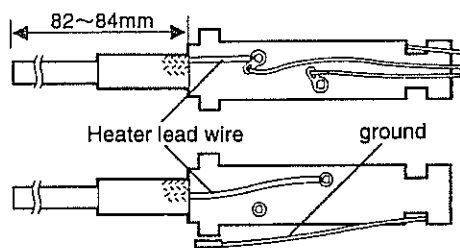

#### CAUTION:

Make sure that the insulation tubes on the heating element lead wires completely cover the lead wires when the heating element is put into place. If the lead wires are showing this will cause the heating element to protrude too far from the terminal board and block the air flow out of the nozzle.

#### 5. Reassemble the iron

- Attach the grounding spring to the sleeve, then slide the tube back over the terminal.
- Pull the cord from the air nozzle side to insert the terminal back in the handle.
- Attach the nipple, nozzle and nut.

#### CAUTION:

The silicone hose should be straight while this is done. Also, be sure to pull all 3 cords (2 white, 1 green) together.

#### 6. Reassemble air nozzle

- Push the packing and cord stopper through the tube and insert in the air nozzle.

#### CAUTION:

Be sure to push the packing and cord stopper through the tube in order to prevent air leakage.

- Screw on the packing retainer.
- Replace the cover on the unit.

#### 7. Calibrate the temperature

After replacing the heating element, be sure to calibrate the temperature to ensure accurate temperature control.

- Attach  $\varnothing$  2.0mm (0.08 in.) nozzle and set the blow selector switch to Hi. Set the temperature control knob to "8" and the air flow control knob to "5", then heat the nozzle for two (2) minutes.
- Using a screwdriver, adjust the CAL control until the temperature of the air 2mm (0.08 in.) from the blow exit aperture 540°C (1004°F).

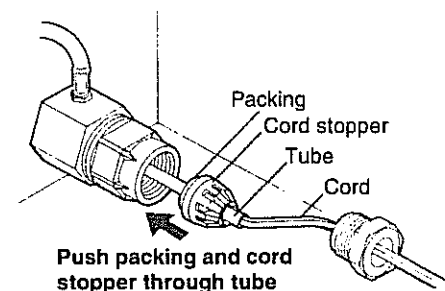

Push packing and cord stopper through tube

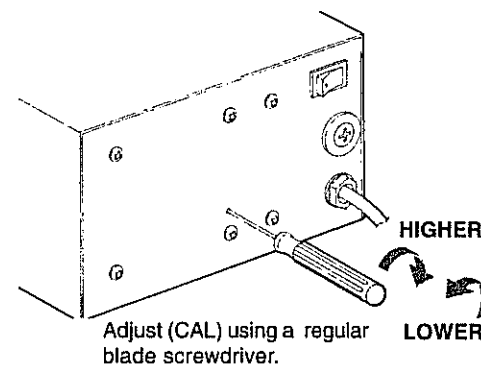
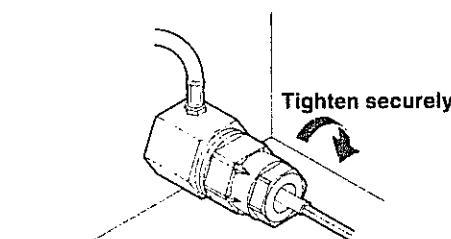

Adjust (CAL) using a regular blade screwdriver.

# 7. PARTS LIST (Station)

Item No.	Part No.	Part Name	Specifications
1	B1028	Knob	
2	B1853	L.E.D. Lamp	
3	B1084	Switch	
4	B1202	Exhaust nozzle	
5	B1204	Rubber foot	
6	B1195	Chassis	
7	B1197	Potentiometer	5K $\Omega$
8	B1856	Air nozzle	
9	B1199	Silicone tube	$\phi 4 \times 90l$
10	B1200	Distribution tube	
11	B1217	Pump	120V

Item No.	Part No.	Part Name	Specifications
12	B1212	Nozzle holder	
13	B1193	Handle	
14	B1194	Cover	
15	B1855	Locking spacer	
16	B1218	P.W.B.	120V
17	B1207	Wiring board	
18	B1041	Fuse holder	w/o fuse
19	B1042	Fuse	2A
20	B1208	Cord stopper	
21	B1190	Holder	w/iron receptacle & Thumb screw
22	B1191	Iron receptacle	
23	B1192	Thumb screw	

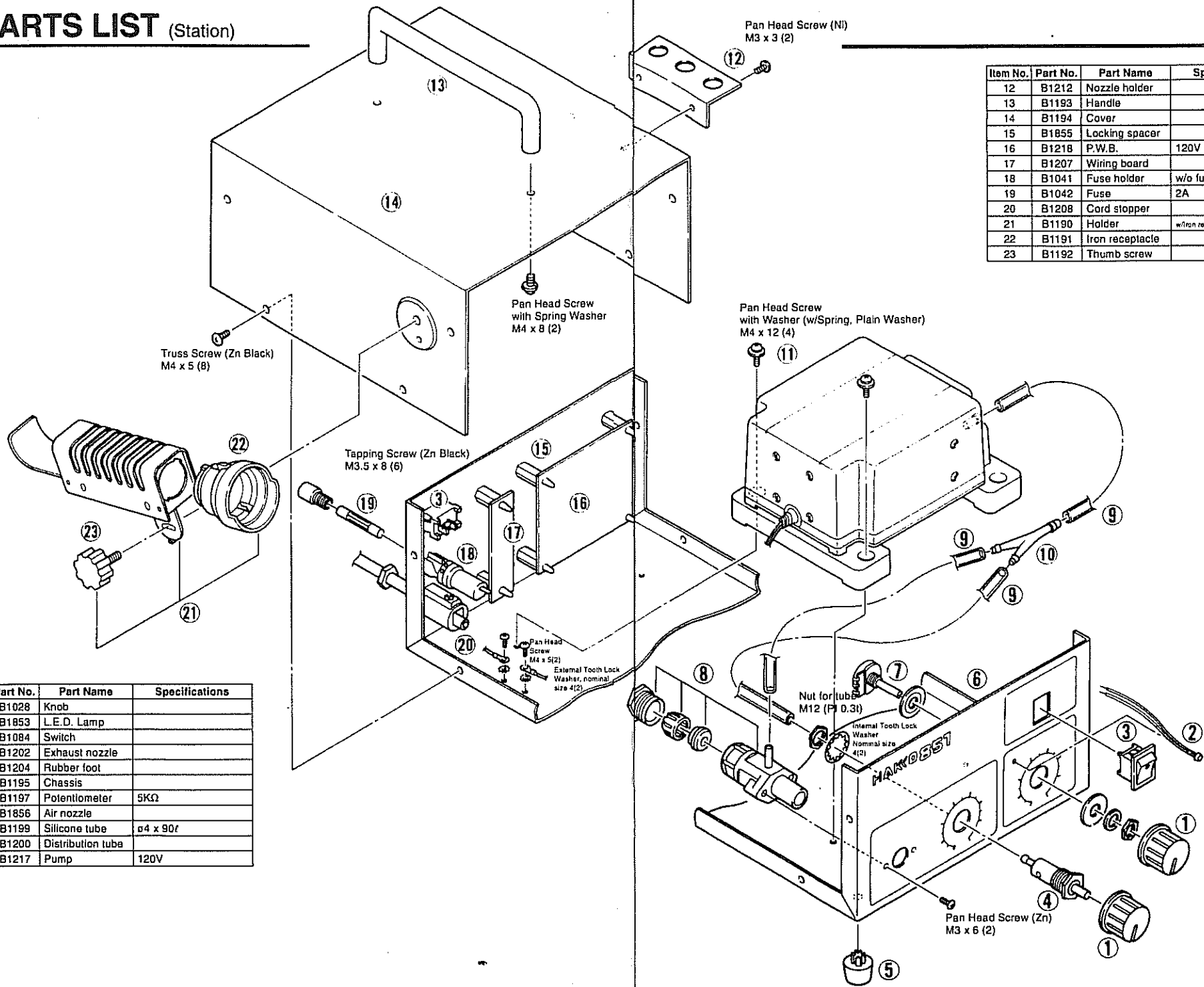

## 7. PARTS LIST (Iron)

Item No.	Part No.	Part Name	Specifications
1	B1182	Nut	with Stopper
2	A1065	Nozzle	ø1.5mm(0.06 in.) with nut
	A1066	Nozzle	ø2.0mm(0.08 in.) with nut
	A1067	Nozzle	ø3.0mm(0.12 in.) with nut
3	B1183	Nipple	with O-ring (P15)
4	B1213	O-ring (P15)	
5	B1184	Grounding spring	
6	A1068	Heating element	120V-80W, Ceramic
7	B1187	Terminal	with Cord stopper
8	B1189	Cord	
9	B1186	Handle cover	
10	B1185	Handle	with Handle cover
11	B1188	Silicone hose	

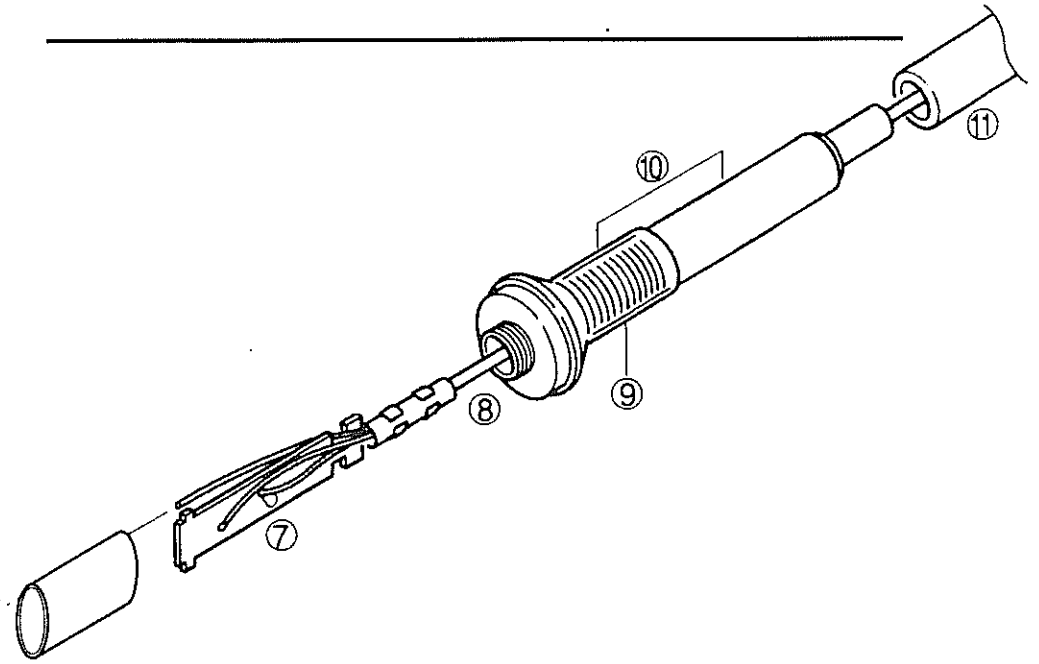
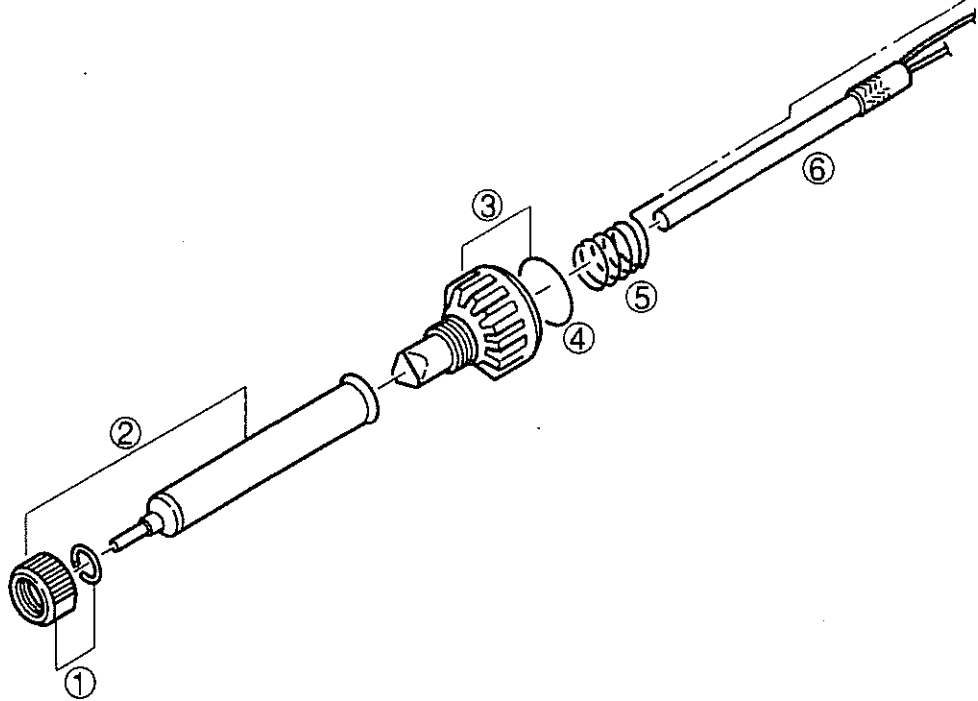

# 8. TEMPERATURE DISTRIBUTION CHARTS

Measurement conditions: Maximum air temperature measured 2mm (0.08 in.) from blow exit aperture)

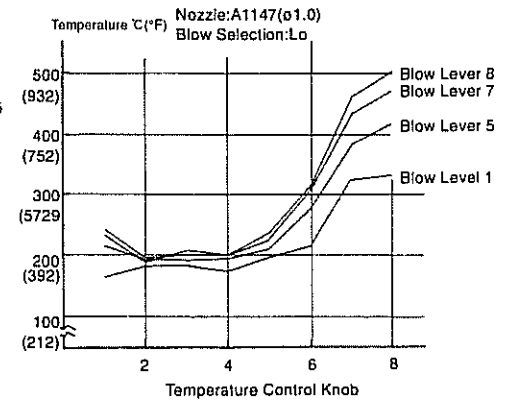
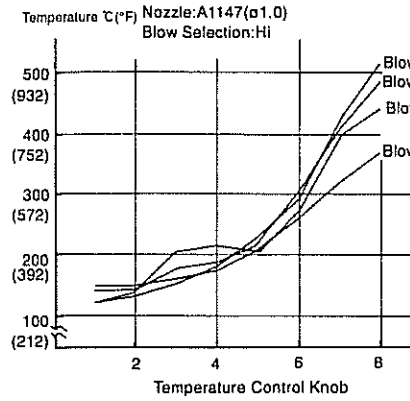
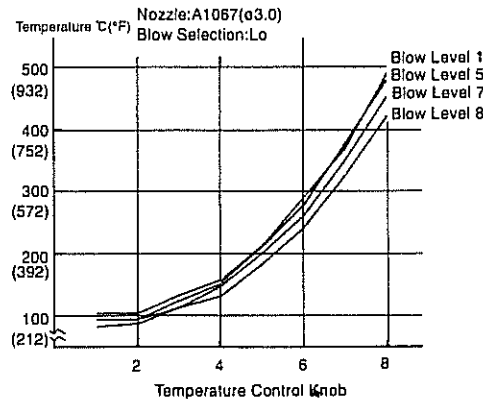
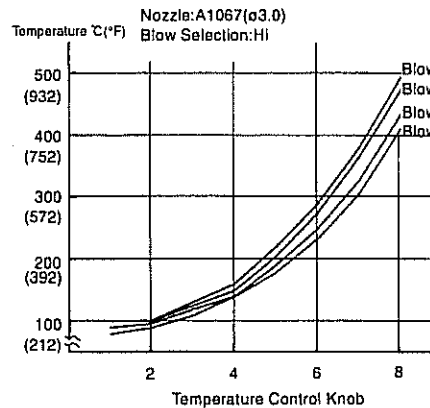
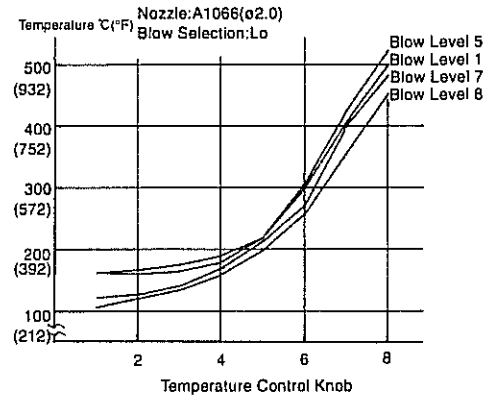
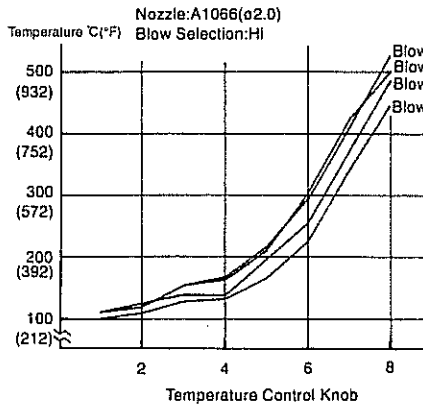
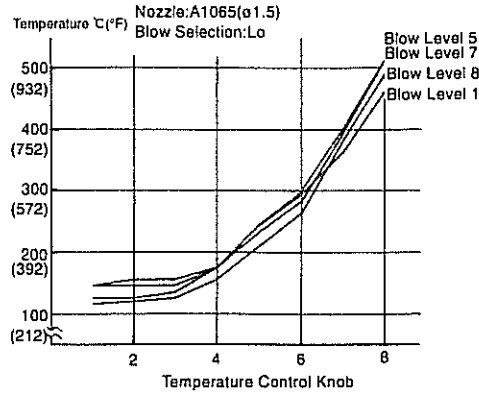
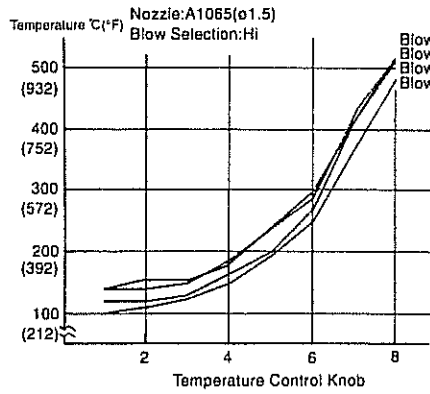

**CAUTION:**  
These charts are for reference.





## **HAKKO CORPORATION**

### **HEAD OFFICE**

4-5, SHIOKUSA 2-CHOME, NANIWA-KU, OSAKA, 556-0024 JAPAN

TEL: +81-6-6561-3225 FAX: +81-6-6561-8466

<http://www.hakko.com>

### **AMERICAN HAKKO PRODUCTS, INC.**

28920 N. AVENUE WILLIAMS VALENCIA CA 91355, U.S.A.

TEL: (661) 294-0090 FAX: (661) 294-0096

Toll Free (800)88-HAKKO [www.hakkousa.com](http://www.hakkousa.com)

4 2 5 5 6

Oct.2003  
MA00071YB031031