

| PART NUMBER | CKT SIZE | LUBRICATION |
|-------------|----------|-------------|
| 87599-1001  | 136      | YES         |
| 87599-1011  | 136      | NO          |

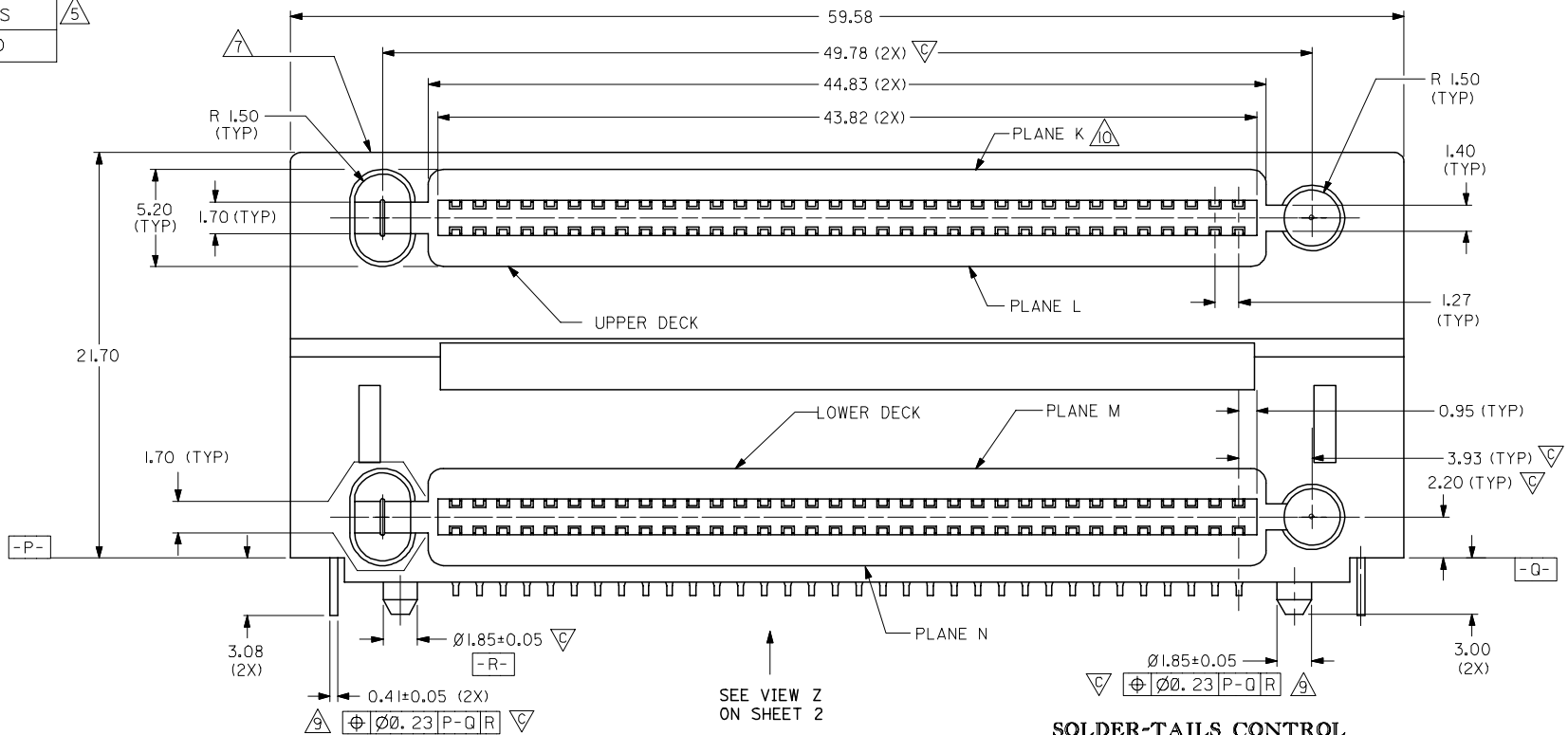

NOTES

- MATERIAL:  
HOUSING: LCP, 30% GLASS FILLED, UL94V-0, BLACK  
TERMINALS: PHOSPHOR BRONZE  
THREADED INSERT: BRASS
- PLATING:  
0.76um MIN. GOLD IN SELECTIVE CONTACT AREA AND  
2.54um MIN. TIN IN SOLDER-TAIL AREA,  
BOTH OVER 1.27um MIN. NICKEL.
- RECOMMENDED PCB THICKNESS IS 1.57mm.
- CIRCUIT #58 TO BE RECESSED 0.50mm. BEHIND ALL OTHER CONTACTS.
- LUBRICATION TYPE IS NYETA CT 570H-2
- TO MATE WITH MOLEX P/N 71661-7068
- 4-DIGIT DATECODE "YYWW" TO BE LOCATED AS SHOWN. EXAMPLE: "9818"
- THREADED INSERT DEPTH FROM SEATING PLANE IS 7.70mm.
- ALL POSITIONAL TOLERANCE TO BE GAUGED.
- BOW ALLOWABLE ON PLANE K, L, M, N SHALL BE  
0.13mm MAX BEFORE IR AND 0.20mm MAX AFTER IR

**SOLDER-TAILS CONTROL**

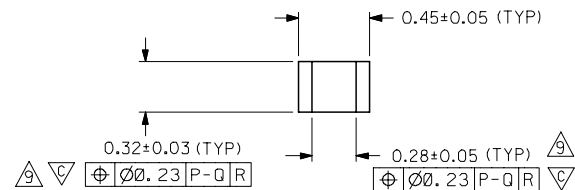

|                                                                                         |          |                                                       |                                |                                       |       |                                                                                                                               |  |                                   |                        |                        |  |
|-----------------------------------------------------------------------------------------|----------|-------------------------------------------------------|--------------------------------|---------------------------------------|-------|-------------------------------------------------------------------------------------------------------------------------------|--|-----------------------------------|------------------------|------------------------|--|
| OBS TIN/LEAD P/N<br>EC NO: S2006-0729<br>DRWN: M.LONG<br>CHKD: S.HONG<br>APPR: K.C.LING | REV<br>C | DESCRIPTION<br>2006/02/27<br>2006/02/27<br>2006/02/28 | QUALITY SYMBOLS<br>▽=0<br>▽C=8 | GENERAL TOLERANCES (UNLESS SPECIFIED) |       | DIMENSION STYLE<br>MM ONLY                                                                                                    |  | SCALE<br>NTS                      | DESIGN UNITS<br>METRIC | THIRD ANGLE PROJECTION |  |
|                                                                                         |          |                                                       |                                | mm                                    | INCH  | DRAWN BY<br>PTL IM                                                                                                            |  | TITLE<br>EBBI STACKED, RECEPTACLE |                        | MOLEX INCORPORATED     |  |
|                                                                                         |          |                                                       |                                | 4 PLACES ± ---                        | ± --- | DATE<br>1998/04/30                                                                                                            |  |                                   |                        |                        |  |
|                                                                                         |          |                                                       |                                | 3 PLACES ± ---                        | ± --- | CHECKED BY<br>SKTOH                                                                                                           |  | DATE<br>1998/07/02                |                        |                        |  |
| 2 PLACES ± 0.25                                                                         | ± ---    | APPROVED BY<br>JAMES                                  |                                | DATE<br>1998/07/06                    |       | DOCUMENT NO.<br>SD-87599-001                                                                                                  |  | SHEET NO.<br>1 OF 3               |                        |                        |  |
| 1 PLACE ± ---                                                                           | ± ---    | ANGULAR ± 3 °                                         |                                | MATERIAL NO.                          |       | SEE TABLE                                                                                                                     |  |                                   |                        |                        |  |
| DRAFT WHERE APPLICABLE<br>MUST REMAIN WITHIN DIMENSIONS                                 |          |                                                       |                                | SIZE<br>A3                            |       | THIS DRAWING CONTAINS INFORMATION THAT IS PROPRIETARY TO MOLEX INCORPORATED AND SHOULD NOT BE USED WITHOUT WRITTEN PERMISSION |  |                                   |                        |                        |  |

10 9 8 7 6 5 4 3 2 1

F

E

D

C

B

A

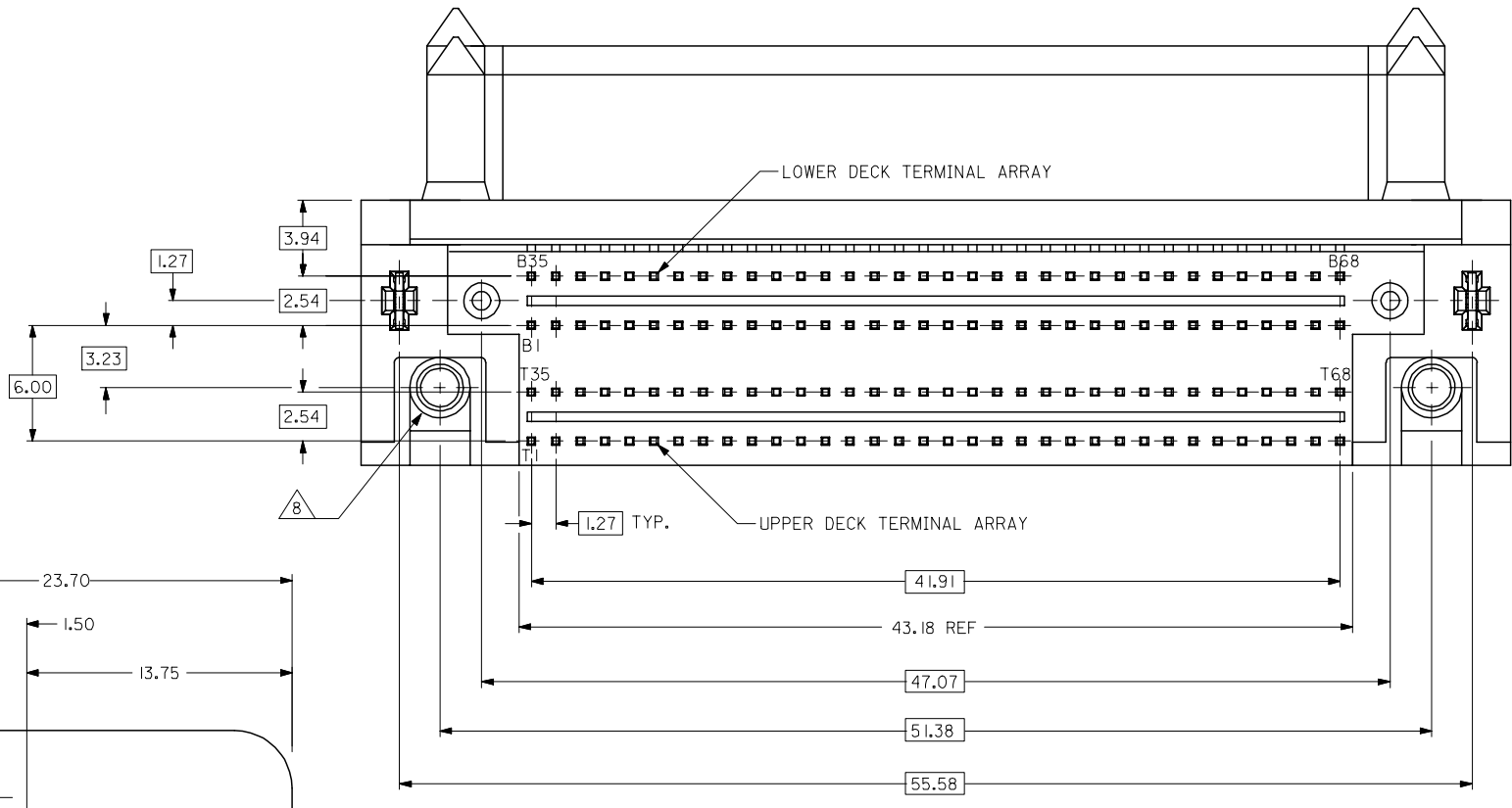

**VIEW Z**

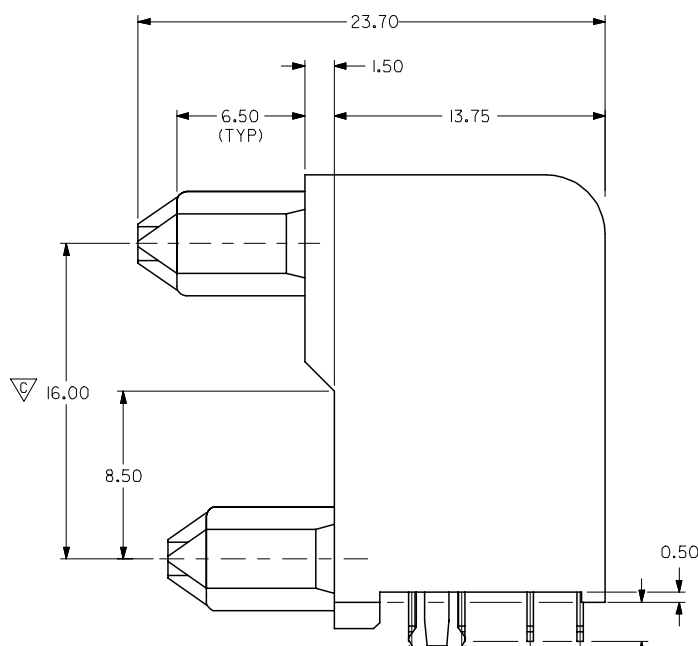

**SIDE VIEW**

$\triangle 8$   $\phi \pm 0.23$  P-Q R

|                   |            |
|-------------------|------------|
| OBS TIN/LEAD P/N  | 2006/02/27 |
| EC NO: S2006-0729 | 2006/02/27 |
| DRWN:MLONG        | 2006/02/27 |
| CHKD:SHONG        | 2006/02/28 |
| APPR:KCLING       |            |

|                 |              |
|-----------------|--------------|
| QUALITY SYMBOLS | $\nabla = 0$ |
|                 | $\nabla = 2$ |
| DESCRIPTION     |              |
| REV             |              |

|                                                      |            |           |
|------------------------------------------------------|------------|-----------|
| GENERAL TOLERANCES (UNLESS SPECIFIED)                | mm         | INCH      |
| 4 PLACES                                             | $\pm$ ---  | $\pm$ --- |
| 3 PLACES                                             | $\pm$ ---  | $\pm$ --- |
| 2 PLACES                                             | $\pm 0.25$ | $\pm$ --- |
| 1 PLACE                                              | $\pm$ ---  | $\pm$ --- |
| ANGULAR $\pm 3^\circ$                                |            |           |
| DRAFT WHERE APPLICABLE MUST REMAIN WITHIN DIMENSIONS |            |           |

|                 |              |                          |              |                        |
|-----------------|--------------|--------------------------|--------------|------------------------|
| DIMENSION STYLE |              | SCALE                    | DESIGN UNITS | THIRD ANGLE PROJECTION |
| MM ONLY         |              | NTS                      | METRIC       | $\triangle$            |
| DRAWN BY        | DATE         | TITLE                    |              |                        |
| PTL IM          | 1998/04/30   | EBBI STACKED, RECEPTACLE |              |                        |
| CHECKED BY      | DATE         | MOLEX INCORPORATED       |              |                        |
| SKTOH           | 1998/07/02   | MOLEX INCORPORATED       |              |                        |
| APPROVED BY     | DATE         | MOLEX INCORPORATED       |              |                        |
| JAMES           | 1998/07/06   | MOLEX INCORPORATED       |              |                        |
| MATERIAL NO.    | DOCUMENT NO. | SHEET NO.                |              |                        |
| SEE TABLE       | SD-87599-001 | 2 OF 3                   |              |                        |

|      |                                                                                                                               |  |  |
|------|-------------------------------------------------------------------------------------------------------------------------------|--|--|
| SIZE | THIS DRAWING CONTAINS INFORMATION THAT IS PROPRIETARY TO MOLEX INCORPORATED AND SHOULD NOT BE USED WITHOUT WRITTEN PERMISSION |  |  |
| A3   |                                                                                                                               |  |  |

9 8 7 6 5 4 3 2 1

**RECOMMENDED PCB LAYOUT**

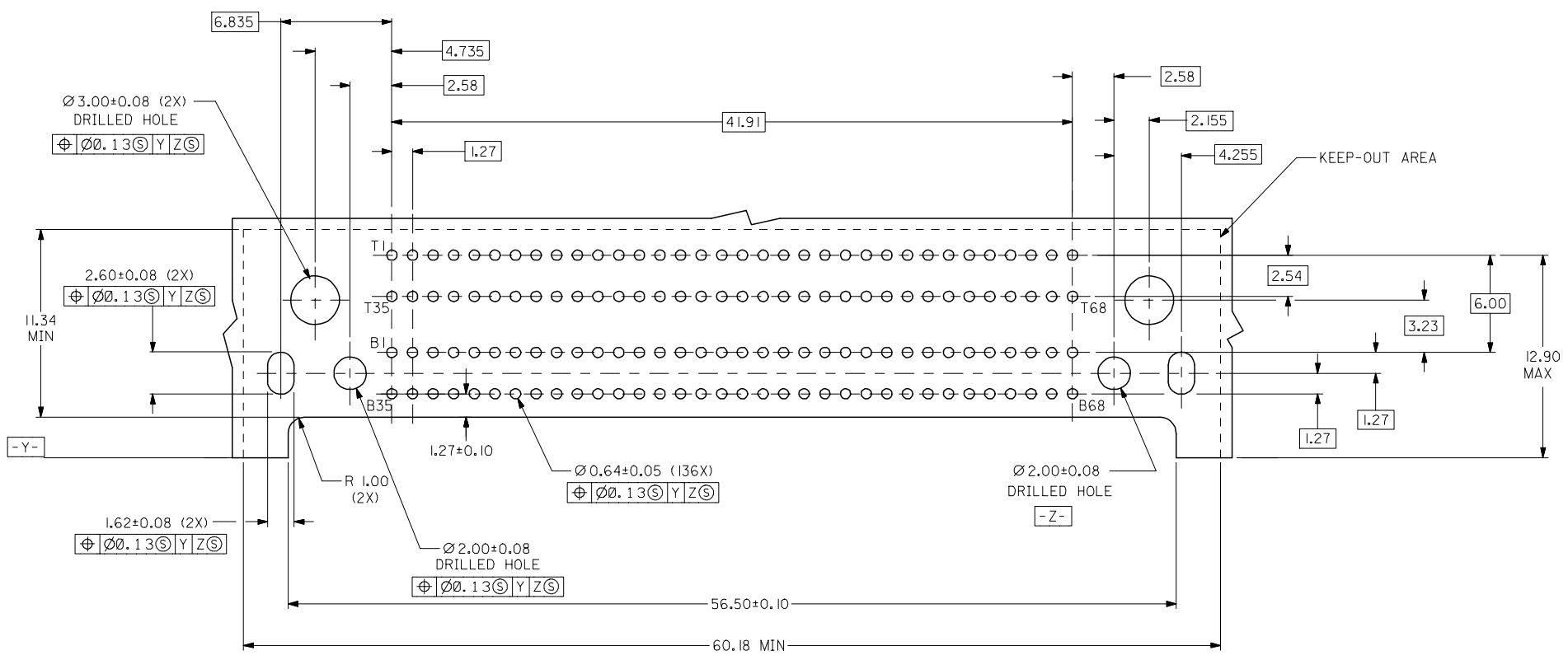

|                                                                                                                   |                       |                                       |                                                                                                                               |                                   |              |                        |
|-------------------------------------------------------------------------------------------------------------------|-----------------------|---------------------------------------|-------------------------------------------------------------------------------------------------------------------------------|-----------------------------------|--------------|------------------------|
| OBS TIN/LEAD P/N<br>EC NO: S2006-0729<br>DRWN:MLONG 2006/02/27<br>CHKD:SHONG 2006/02/27<br>APPR:KCLING 2006/02/28 | QUALITY SYMBOLS       | GENERAL TOLERANCES (UNLESS SPECIFIED) | DIMENSION STYLE                                                                                                               | SCALE                             | DESIGN UNITS | THIRD ANGLE PROJECTION |
|                                                                                                                   | ▽=0                   | mm                                    | MM ONLY                                                                                                                       | NTS                               | METRIC       |                        |
|                                                                                                                   | ∇=0                   | INCH                                  |                                                                                                                               |                                   |              |                        |
|                                                                                                                   |                       | 4 PLACES ± --- ± ---                  | DRAWN BY DATE                                                                                                                 | TITLE<br>EBBI STACKED, RECEPTACLE |              |                        |
|                                                                                                                   |                       | 3 PLACES ± --- ± ---                  | PTL IM 1998/04/30                                                                                                             |                                   |              |                        |
|                                                                                                                   | 2 PLACES ± 0.25 ± --- | CHECKED BY DATE                       | MOLEX INCORPORATED                                                                                                            |                                   |              |                        |
|                                                                                                                   | 1 PLACE ± --- ± ---   | SKTOH 1998/07/02                      |                                                                                                                               |                                   |              |                        |
|                                                                                                                   | ANGULAR ± 3 °         | APPROVED BY DATE                      | DOCUMENT NO. SHEET NO.                                                                                                        |                                   |              |                        |
|                                                                                                                   |                       | JAMES 1998/07/06                      |                                                                                                                               |                                   |              | SD-87599-001           |
|                                                                                                                   |                       | MATERIAL NO.                          | THIS DRAWING CONTAINS INFORMATION THAT IS PROPRIETARY TO MOLEX INCORPORATED AND SHOULD NOT BE USED WITHOUT WRITTEN PERMISSION |                                   |              |                        |
|                                                                                                                   |                       | SIZE A3                               |                                                                                                                               |                                   |              |                        |

|                                                      |  |           |  |              |  |        |  |
|------------------------------------------------------|--|-----------|--|--------------|--|--------|--|
| DRAFT WHERE APPLICABLE MUST REMAIN WITHIN DIMENSIONS |  | SEE TABLE |  | SD-87599-001 |  | 3 OF 3 |  |
|------------------------------------------------------|--|-----------|--|--------------|--|--------|--|