



White LED Current Regulator with 1x/1.5x High-Efficiency Charge Pump

MAX1570

General Description

The MAX1570 fractional charge pump drives up to five white LEDs with regulated constant current for uniform intensity. The MAX1570 maintains the highest possible efficiency over the full 1-cell lithium-ion (Li+) battery input voltage range by utilizing a 1x/1.5x fractional charge pump and very-low-dropout current regulators. The MAX1570 operates with 1MHz fixed-frequency switching, allowing for tiny external components. The regulation scheme is optimized to ensure low EMI and low input ripple.

An external resistor sets the full-scale LED current, while two digital inputs control on/off and select between three levels of brightness. A pulse-width modulation (PWM) signal can also be used to modulate LED brightness.

The MAX1570 is available in 16-pin 4mm × 4mm Thin QFN packaging (0.8mm max height).

Applications

White LED Backlighting
Cell Phones and Smart Phones
PDA and Palmtop Computers
Portable MP3 Players
Digital Cameras and Camcorders

Pin Configuration

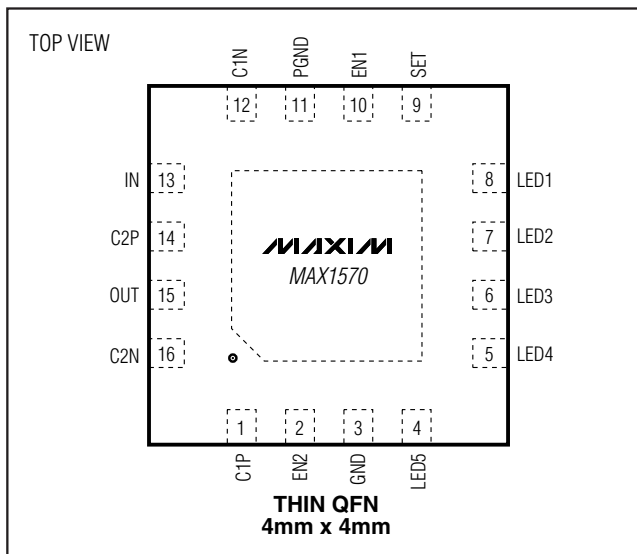

Features

- ◆ Excellent 0.3% LED-to-LED Current Matching
- ◆ 30mA/LED Drive Capability
- ◆ Proprietary 1x/1.5x Modes for Ultra-High Efficiency
- ◆ Low Input Ripple and EMI
- ◆ Eliminates Ballast Resistors
- ◆ Digital or PWM LED Dimming Control
- ◆ 0.1µA Shutdown Current
- ◆ 2.7V to 5.5V Supply Voltage Range
- ◆ Soft-Start Limits Inrush Current
- ◆ Thermal-Shutdown Protection
- ◆ No External Inductor, Schottky, or Zener Diode Required
- ◆ Tiny 16-Pin 4mm × 4mm Thin QFN Package
- ◆ Protected by U.S. Patent #6,538,394 B2

Ordering Information

PART	TEMP RANGE	PIN-PACKAGE
MAX1570ETE	-40°C to +85°C	16 Thin QFN

Typical Operating Circuit

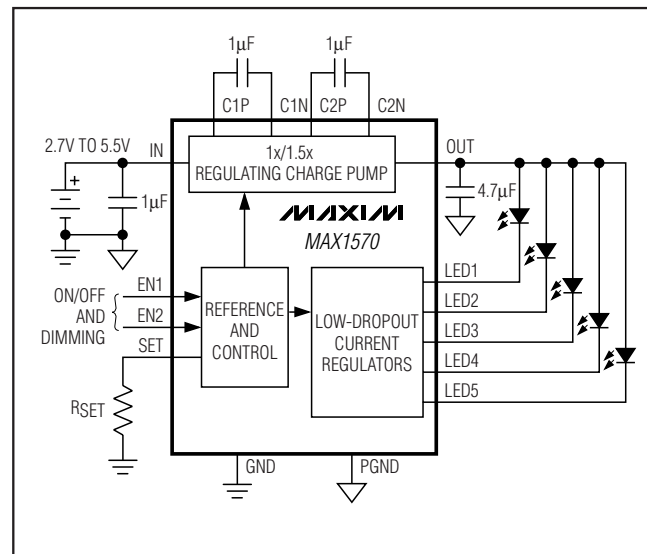

White LED Current Regulator with 1x/1.5x High-Efficiency Charge Pump

ABSOLUTE MAXIMUM RATINGS

IN, OUT, EN1, EN2 to GND	-0.3V to +6V
SET, LED1, LED2, LED3, LED4, LED5 to GND	-0.3V to (V _{IN} + 0.3V)
PGND to GND	-0.3 to +0.3V
C1N, C2N to GND	-0.3V to (V _{IN} + 1V)
C1P, C2P to GND	-0.3V to the greater (V _{OUT} + 1V) or (V _{IN} + 1V)
OUT Short Circuit to GND	Indefinite

Continuous Power Dissipation (T _A = +70°C) 16-Pin Thin QFN (derate 16.9 mW/°C)	1349mW
Operating Temperature Range	-40°C to +85°C
Junction Temperature	+150°C
Storage Temperature Range	-65°C to +150°C
Lead Temperature (soldering, 10s)	+300°C

Stresses beyond those listed under "Absolute Maximum Ratings" may cause permanent damage to the device. These are stress ratings only, and functional operation of the device at these or any other conditions beyond those indicated in the operational sections of the specifications is not implied. Exposure to absolute maximum rating conditions for extended periods may affect device reliability.

ELECTRICAL CHARACTERISTICS

(V_{IN} = 3.6V, GND = PGND = 0, EN1 = EN2 = IN, C_{1N} = C₁ = C₂ = 1μF, C_{OUT} = 4.7μF, T_A = 0°C to +85°C, unless otherwise noted. Typical values are at T_A = +25°C.)

PARAMETER	CONDITIONS	MIN	TYP	MAX	UNITS
IN Operating Voltage		2.7		5.5	V
Undervoltage Lockout Threshold	V _{IN} rising or falling	2.25	2.45	2.60	V
Undervoltage Lockout Hysteresis			35		mV
Supply Current	1MHz switching, no load		2.0	3.5	mA
Shutdown Supply Current	EN1 = EN2 = GND		0.1	5	μA
Soft-Start Done Time			2.1		ms
SET Bias Voltage	EN1 = GND, EN2 = IN, I _{SET} = 33μA	0.190	0.200	0.210	V
	EN1 = IN, EN2 = GND, I _{SET} = 67μA	0.380	0.400	0.420	
	EN1 = IN, EN2 = IN, I _{SET} = 100μA	0.570	0.600	0.630	
SET Leakage in Shutdown	EN1 = EN2 = GND, V _{IN} = 5.5V, V _{SET} = 0 or 5.5V		0.01	1.00	μA
SET Current Range		20		130	μA
SET to LED_ Current Ratio	I _{LED} /I _{SET} , I _{SET} = 67μA, V _{LED_} = 1V	215	230	245	A/A
LED_ to LED_ Current Matching	I _{SET} = 67μA, V _{LED_} = 1V	-3	0.3	+3	%
Maximum LED_ Sink Current	I _{SET} = 130μA, V _{LED_} = 1V	28	30		mA
LED_ Dropout Voltage	I _{SET} = 33μA (Note 1)		100	180	mV
	I _{SET} = 67μA (Note 2)		200	360	
	I _{SET} = 100μA (Note 2)		230	410	
LED1 Regulation Voltage (1.5x Mode)	EN1 = GND, EN2 = IN, I _{SET} = 33μA	185	200	215	mV
	EN1 = IN, EN2 = GND, I _{SET} = 67μA	277	300	323	
	EN1 = IN, EN2 = IN, I _{SET} = 100μA	360	400	440	
LED Leakage in Shutdown	EN1 = GND, EN2 = GND, V _{LED_} = 5.5V		0.01	1.00	μA
Maximum OUT Current	IN ≥ 3.4V, OUT ≥ 3.9V	150			mA
Open-Loop OUT Resistance	1x mode (V _{IN} - V _{OUT})/I _{OUT}		1.00	1.75	Ω
	1.5x mode (1.5V _{IN} - V _{OUT})/I _{OUT}			8	
Switching Frequency			1		MHz
EN1, EN2 High Voltage	IN = 2.7V to 5.5V	1.6			V
EN1, EN2 Low Voltage	IN = 2.7V to 5.5V			0.4	V
EN1, EN2 Input Current	EN_ = GND or 5.5V		0.01	1.00	μA

White LED Current Regulator with 1x/1.5x High-Efficiency Charge Pump

MAX1570

ELECTRICAL CHARACTERISTICS (continued)

($V_{IN} = 3.6V$, $GND = PGND = 0$, $EN1 = EN2 = IN$, $C_{IN} = C1 = C2 = 1\mu F$, $C_{OUT} = 4.7\mu F$, $T_A = 0^\circ C$ to $+85^\circ C$, unless otherwise noted. Typical values are at $T_A = +25^\circ C$.)

PARAMETER	CONDITIONS	MIN	TYP	MAX	UNITS
LED1 Dual Mode™ Threshold		50	75	100	mV
Thermal-Shutdown Threshold			160		°C
Thermal-Shutdown Hysteresis			20		°C

ELECTRICAL CHARACTERISTICS

($V_{IN} = 3.6V$, $GND = PGND = 0$, $EN1 = EN2 = IN$, $C_{IN} = C1 = C2 = 1\mu F$, $C_{OUT} = 4.7\mu F$, $T_A = -40^\circ C$ to $+85^\circ C$, unless otherwise noted.) (Note 3)

PARAMETER	CONDITIONS	MIN	MAX	UNITS
IN Operating Voltage		2.7	5.5	V
Undervoltage Lockout Threshold	V_{IN} rising or falling	2.25	2.60	V
Supply Current	1MHz switching, no load		3.5	mA
Shutdown Supply Current	$EN1 = EN2 = GND$		5	μA
SET Bias Voltage	$EN1 = GND$, $EN2 = IN$, $I_{SET} = 33\mu A$	0.190	0.210	V
	$EN1 = IN$, $EN2 = GND$, $I_{SET} = 67\mu A$	0.380	0.420	
	$EN1 = IN$, $EN2 = IN$, $I_{SET} = 100\mu A$	0.570	0.630	
SET Leakage in Shutdown	$EN1 = EN2 = GND$, $V_{IN} = 5.5V$, $V_{SET} = 0$ or $5.5V$		1	μA
SET Current Range		20	130	μA
SET to LED_ Current Ratio	I_{LED}/I_{SET} , $I_{SET} = 67\mu A$, $V_{LED_} = 1V$	215	250	A/A
LED_ to LED_ Current Matching	$I_{SET} = 67\mu A$, $V_{LED_} = 1V$	-3	+3	%
Maximum LED_ Sink Current	$I_{SET} = 130\mu A$, $V_{LED_} = 1V$	28		mA
LED_ Dropout Voltage	$I_{SET} = 33\mu A$ (Note 1)		180	mV
	$I_{SET} = 67\mu A$ (Note 2)		360	
	$I_{SET} = 100\mu A$ (Note 2)		410	
LED1 Regulation Voltage (1.5x Mode)	$EN1 = GND$, $EN2 = IN$, $I_{SET} = 33\mu A$	185	215	mV
	$EN1 = IN$, $EN2 = GND$, $I_{SET} = 67\mu A$	277	323	
	$EN1 = IN$, $EN2 = IN$, $I_{SET} = 100\mu A$	360	440	
LED Leakage in Shutdown	$EN1 = GND$, $EN2 = GND$, $V_{LED_} = 5.5V$		1	μA
Maximum OUT Current	$IN \geq 3.4V$, $OUT \geq 3.9V$	150		mA
Open-Loop OUT Resistance	1x mode $(V_{IN} - V_{OUT})/I_{OUT}$		1.75	Ω
	1.5x mode $(1.5V_{IN} - V_{OUT})/I_{OUT}$		8	
EN1, EN2 High Voltage	$IN = 2.7V$ to $5.5V$	1.6		V
EN1, EN2 Low Voltage	$IN = 2.7V$ to $5.5V$		0.4	V
EN1, EN2 Input Current	$EN_ = GND$ or $5.5V$		1	μA
LED1 Dual Mode Threshold		50	100	mV

Note 1: Dropout voltage is defined as the LED_ to GND voltage at which current sink into LED_ drops 20% from the value at LED_ = 1V.

Note 2: Dropout voltage is defined as the LED_ to GND voltage at which current sink into LED_ drops 10% from the value at LED_ = 1V.

Note 3: Specifications to $-40^\circ C$ are guaranteed by design and not production tested.

Dual Mode is a trademark of Maxim Integrated Products, Inc.

White LED Current Regulator with 1x/1.5x High-Efficiency Charge Pump

Typical Operating Characteristics

(EN1 = EN2 = IN, C_{IN} = 1μF, C1 = C2 = 1μF, C_{OUT} = 4.7μF, R_{SET} = 9.09kΩ, T_A = +25°C, unless otherwise noted.)

LED EFFICIENCY vs. SUPPLY VOLTAGE (4 LEDs)

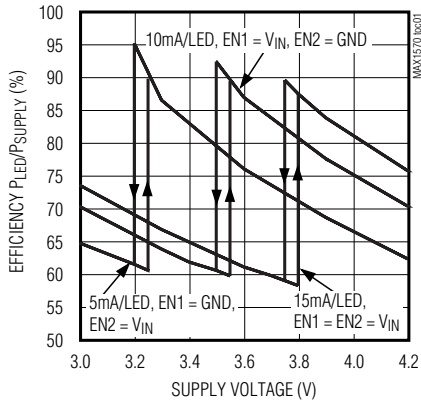

SUPPLY POWER vs. SUPPLY VOLTAGE (4 LEDs)

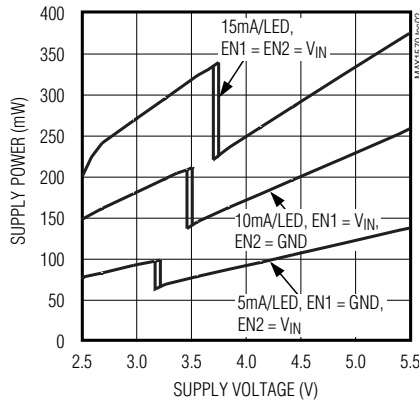

SUPPLY CURRENT vs. SUPPLY VOLTAGE (4 LEDs)

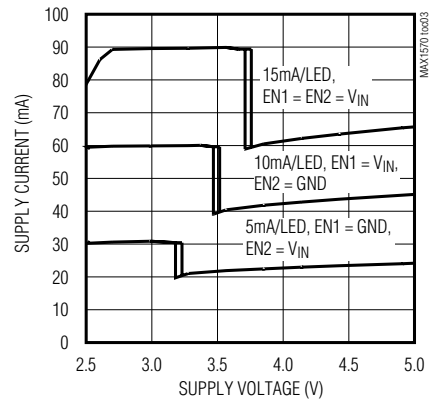

LED EFFICIENCY vs. SUPPLY VOLTAGE (5 LEDs)

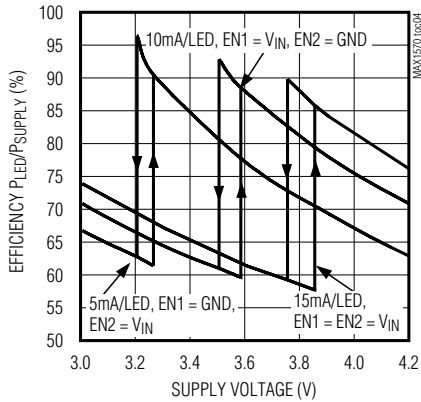

SUPPLY POWER vs. SUPPLY VOLTAGE (5 LEDs)

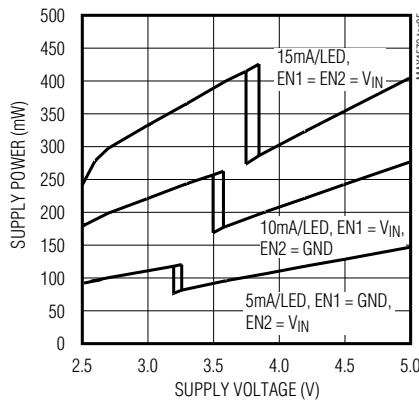

SUPPLY CURRENT vs. SUPPLY VOLTAGE (5 LEDs)

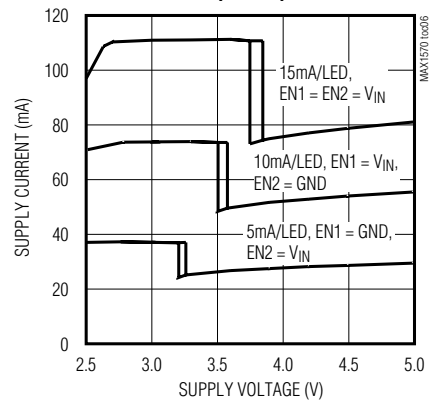

EFFICIENCY vs. LED CURRENT (4 LEDs, EN1 = PWM AT 1kHz)

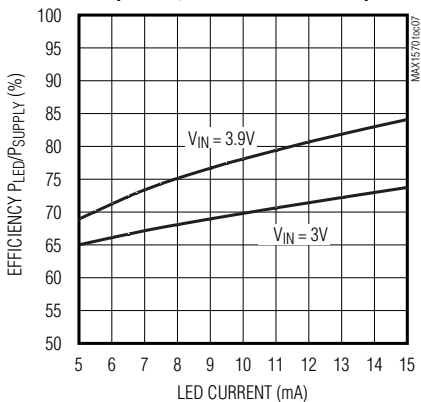

LED CURRENT vs. PWM DIMMING DUTY CYCLE INTO EN1 (5 LEDs)

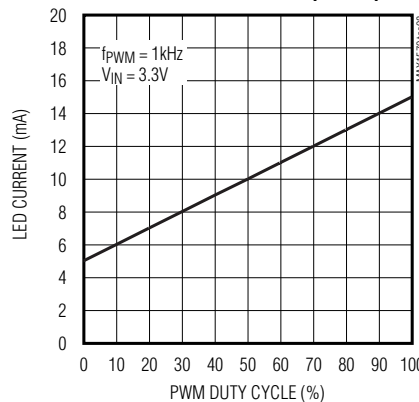

SUPPLY CURRENT vs. SUPPLY VOLTAGE (4 LEDs, LED1 OPEN FOR 1.5X ONLY MODE)

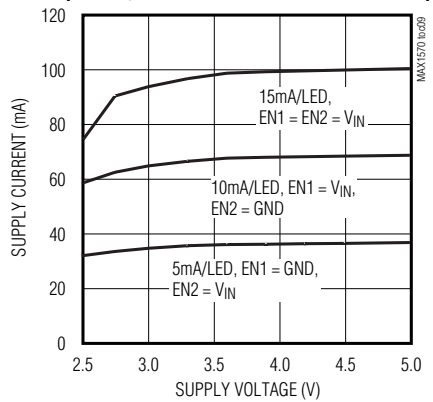

White LED Current Regulator with 1x/1.5x High-Efficiency Charge Pump

MAX1570

Typical Operating Characteristics (continued)

(EN1 = EN2 = IN, C_{IN} = 1μF, C1 = C2 = 1μF, C_{OUT} = 4.7μF, R_{SET} = 9.09kΩ, T_A = +25°C, unless otherwise noted.)

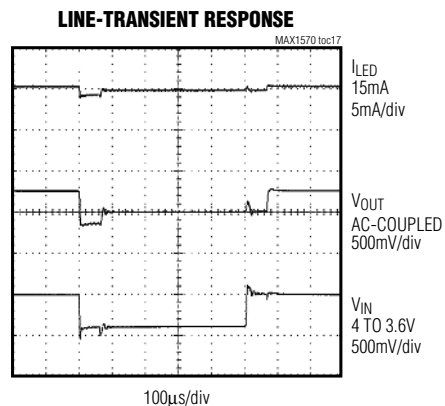
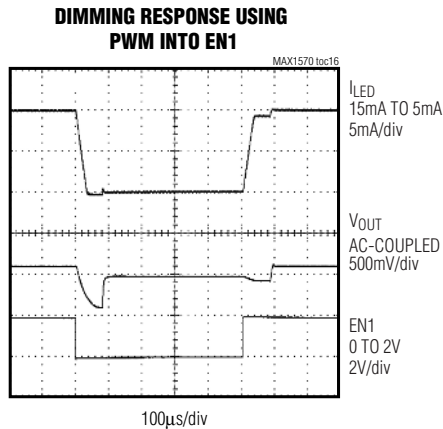
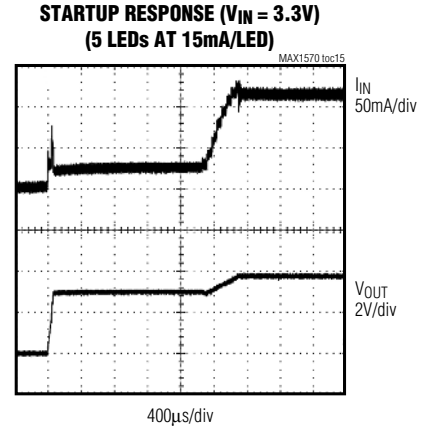
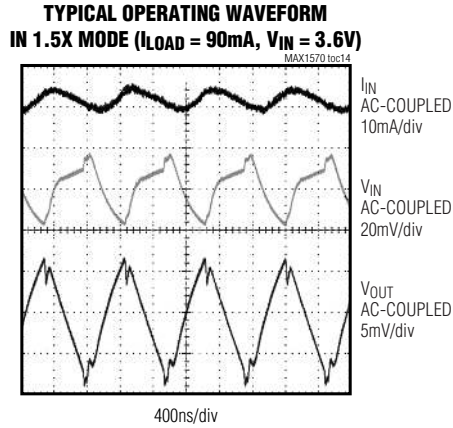
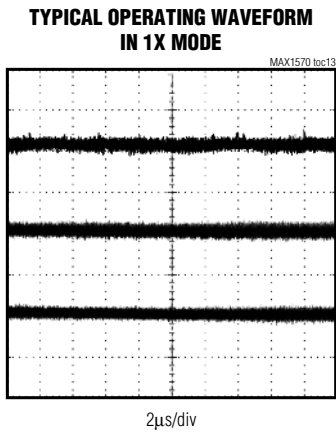
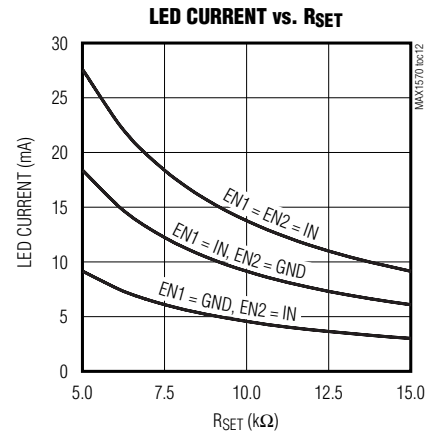
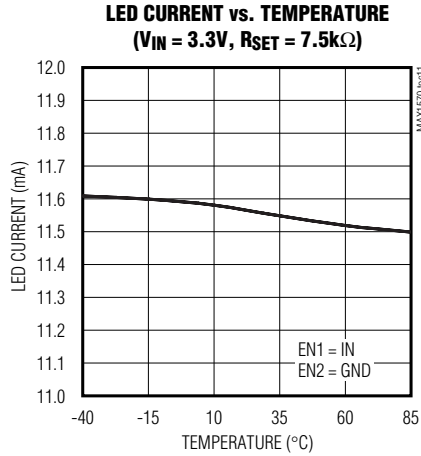
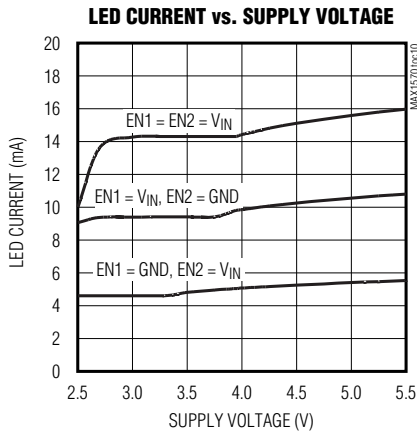

White LED Current Regulator with 1x/1.5x High-Efficiency Charge Pump

Pin Description

PIN	NAME	FUNCTION
1	C1P	Transfer Capacitor 1 Positive Connection
2	EN2	Enable, Dimming Control Input 2. EN2 and EN1 control shutdown, 1/3 current, 2/3 current, and full current (see Table 1).
3	GND	Analog Ground. Connect directly to the exposed paddle underneath the IC.
4	LED5	LED5 Cathode Connection. Current flowing into LED5 is 230 times the current flowing out of SET. When using fewer than five LEDs, this pin can be left unconnected. LED5 is high impedance during shutdown.
5	LED4	LED4 Cathode Connection. Current flowing into LED4 is 230 times the current flowing out of SET. When using fewer than five LEDs, this pin can be left unconnected. LED4 is high impedance during shutdown.
6	LED3	LED3 Cathode Connection. Current flowing into LED3 is 230 times the current flowing out of SET. When using fewer than five LEDs, this pin can be left unconnected. LED3 is high impedance during shutdown.
7	LED2	LED2 Cathode Connection. Current flowing into LED2 is 230 times the current flowing out of SET. When using fewer than five LEDs, this pin can be left unconnected. LED2 is high impedance during shutdown.
8	LED1	LED1 Cathode Connection and Charge-Pump Feedback. Current flowing into LED1 is 230 times the current flowing out of SET. The charge pump regulates the voltage on LED1 to various voltages depending upon the status of EN1 and EN2 (see Table 1). Grounding LED1 forces OUT to operate at 5V while LED2–LED5 regulate the LED current to $230 \times V_{SET}/R_{SET}$. LED1 is high impedance during shutdown.
9	SET	Bias Current Set Input. The current flowing out of SET programs the bias current into each LED by $I_{LED} = 230 \times I_{SET}$. V_{SET} is internally biased to various voltages (see Table 1). Connect a resistor to GND to set the bias current as V_{SET}/R_{SET} . SET is high impedance during shutdown.
10	EN1	Enable, Dimming Control Input 1. EN1 and EN2 control shutdown, 1/3 current, 2/3 current, and full current (see Table 1).
11	PGND	Power Ground. Charge-pump switching current flows through this pin. Connect to GND and system ground as close to the MAX1570 and the input bypass capacitor as possible.
12	C1N	Transfer Capacitor 1 Negative Connection
13	IN	Supply Voltage Input. Bypass IN to PGND with a $1\mu\text{F}$ ceramic capacitor. The input voltage range is 2.7V to 5.5V. IN is high impedance during shutdown.
14	C2P	Transfer Capacitor 2 Positive Connection
15	OUT	Charge-Pump Output. Bypass to PGND with a $4.7\mu\text{F}$ ceramic capacitor as close to the IC as possible. Connect to the anodes of all the LEDs. OUT is high impedance during shutdown.
16	C2N	Transfer Capacitor 2 Negative Connection
—	EP	Exposed paddle. Connect to GND.

White LED Current Regulator with 1x/1.5x High-Efficiency Charge Pump

Detailed Description

The MAX1570 is a complete charge-pump buck/boost converter requiring only four small ceramic capacitors. The MAX1570 utilizes a proprietary 1x/1.5x fractional charge-pump topology to drive up to five white LEDs with regulated constant current for uniform intensity. The MAX1570 operates with a 1MHz fixed frequency. An external resistor (R_{SET}) programs the full-scale LED current, while two digital inputs control on/off and provide brightness control.

Output Regulation

The MAX1570 operates in 1x charge-pump mode until just above dropout. Then the MAX1570 switches to 1.5x charge-pump mode to regulate the voltage at LED1 and maintain constant LED brightness even at very low battery voltages. Using this topology, there is no LED brightness change during the 1x/1.5x switchover, which guarantees no flicker on the display. The switchover scheme has low hysteresis, minimizing operation in the less efficient 1.5x mode. The 1x mode produces almost no ripple, while the 1.5x mode regulates the output voltage by controlling the rate at which the transfer capacitors are charged. In this way, the switching frequency remains constant for reduced input ripple and stable noise spectrum.

Soft-Start

The MAX1570 includes soft-start circuitry to limit inrush current at turn-on. When starting up with an output voltage that is not near the input voltage, the output capacitor is charged directly from the input with a DAC ramped current source (with no charge-pump action) until the output voltage is near the input voltage. Once this occurs, the charge pump determines if 1x or 1.5x mode is required. In the case of 1x mode, the soft-start is terminated and normal operation begins. In the case of 1.5x mode, soft-start operates until LED1 reaches regulation. In case of an overload condition, soft-start repeats every 2.1ms. If the output is shorted to ground, the output current is limited by the MAX1570 fractional-switching technique and then the device hits thermal shutdown once the die temperature reaches -160°C .

True Shutdown Mode

When EN1 and EN2 are grounded, the MAX1570 is in shutdown, and the charge pump examines whether the input voltage is greater than or less than the output voltage and shorts the transfer capacitor nodes to either IN or OUT as necessary. The output is high impedance in either case.

Thermal Shutdown

The MAX1570 includes a thermal-limit circuit that shuts down the IC at about 160°C . Turn-on occurs after the IC cools by approximately 20°C .

Setting the Output Current

SET controls the LED bias current. Current flowing into LED1, LED2, LED3, LED4, and LED5 is 230 times greater than the current flowing out of SET. Set the output current as follows:

$$I_{LED_} = 230 \times \left(\frac{V_{SET}}{R_{SET}} \right)$$

where $V_{SET} = 0.2\text{V}$, 0.4V , or 0.6V (depending upon EN1 and EN2, see Table 1), and R_{SET} is the resistor connected between SET and GND (see the *Typical Operating Circuit*).

Applications Information

Dimming Using EN1 and EN2

Use EN1 and EN2 inputs as a digital 2-bit number to control on/off, 1/3, 2/3, and full current (see Table 1). EN1 and EN2 control the voltage at SET (V_{SET}). Adjusting the SET voltage controls the current (I_{SET}) through the SET resistor (R_{SET}). Increasing V_{SET} or reducing R_{SET} increases I_{SET} , which then increases the LED current ($I_{LED_}$).

The charge-pump feedback threshold at LED1 is increased as the current is increased to prevent dropout in the current regulators while improving efficiency at lower current settings. LED1 is regulated at 0.2V, 0.3V, or 0.4V when EN1 and EN2 are adjusted for 1/3, 2/3, or full current, respectively (see Table 1). A higher threshold improves LED-to-LED current matching, while a lower threshold improves efficiency by allowing the 1x mode at lower input voltages.

Dimming Using PWM into EN1

Use EN2 for shutdown and drive EN1 with a PWM signal. Current can be varied from 1/3 to full. The waveforms in the *Typical Operating Characteristics* show the response time of dimming. EN2 keeps the part on, eliminating any soft-start delay that would impede PWM control, allowing a PWM frequency up to 5kHz (Figure 1).

Dimming Using a Filtered-PWM Signal

Use a high-frequency PWM signal to drive an R-C-R filter on the SET pin (Figure 2). A 0% PWM duty cycle corresponds to 20mA/LED, while a 100% PWM duty cycle corresponds to 0mA/LED. At PWM frequencies above 5kHz, C3 may be reduced.

White LED Current Regulator with 1x/1.5x High-Efficiency Charge Pump

Table 1. Enable Input Modes

EN_ INPUT LOGIC LEVELS	MODE	LED CURRENT
EN1 = 0, EN2 = 0	Shutdown mode	0
EN1 = 0, EN2 = 1	On, V _{SET} = 200mV, LED1 threshold = 200mV	1/3
EN1 = 1, EN2 = 0	On, V _{SET} = 400mV, LED1 threshold = 300mV	2/3
EN1 = 1, EN2 = 1	On, V _{SET} = 600mV, LED1 threshold = 400mV	Full

Table 2. Capacitor Selection

OUTPUT (mA)	C _{IN} (μF)	C1 (μF)	C2 (μF)	C _{OUT} (μF)
40	1	0.22	0.22	4.7
80	1	0.47	0.47	4.7
150	1	1.0	1.0	4.7

Table 3. Capacitor Manufacturers

COMPONENT NAME	VALUE (μF)	MANUFACTURER	PART NO.	DESCRIPTION
C _{IN}	1	Taiyo Yuden	JMK107BJ105MA	1μF ±20%, 6.3V X5R ceramic capacitor (0603)
C _{OUT}	4.7	Taiyo Yuden	JMK212BJ475MG	4.7μF ±20%, 6.3V X5R ceramic capacitor (0805)
C1 and C2	1	Taiyo Yuden	JMK107BJ105MA	1μF ±20%, 6.3V X5R ceramic capacitor (0603)
	0.47	Taiyo Yuden	LMK107BJ474MA	0.47μF ±20%, 10V X5R ceramic capacitor (0603)
	0.22	Taiyo Yuden	LMK107BJ224KA	0.22μF ±10%, 10V X7R ceramic capacitor (0603)

White LED Current Regulator with 1x/1.5x High-Efficiency Charge Pump

Input Ripple

For LED drivers, input ripple is more important than output ripple. Input ripple depends on the source supply's impedance. Adding a lowpass filter to the input further reduces input ripple. Figure 3 shows a C-R-C filter used to reduce input ripple to less than 2mV_{P-P} when driving a 75mA load. Alternately, increasing C_{IN} to 2.2μF or 4.7μF yields input ripple of 17mV_{P-P} or 9mV_{P-P}, respectively, with only a small increase in footprint. The 1x mode has very low input ripple.

PC Board Layout and Routing

The MAX1570 is a high-frequency switched-capacitor voltage regulator. For best circuit performance, use a solid ground plane and place C_{IN} and C_{OUT} as close to the MAX1570 as possible. Also, place their ground tails close together. Connect PGND and GND directly under the IC to the exposed paddle, and connect C_{IN} and C_{OUT} as close as possible to PGND. The input supply connections should be short; if this is not possible, an additional input supply filter capacitor (tantalum or electrolytic) may be required. Refer to the MAX1570 EV kit for a good layout example.

Component Selection

Typical external component values are shown in Table 2 and Table 3.

Maximum power dissipation occurs around 4.2V on IN and 4.0V at OUT with maximum load current.

$$P_D = \left[\left((1.5 \times V_{IN}) - V_{OUT} \right) + 0.4V \right] \times 120mA = 324mW$$

At higher IN voltages this device switches to 1x mode and power dissipation is lowered.

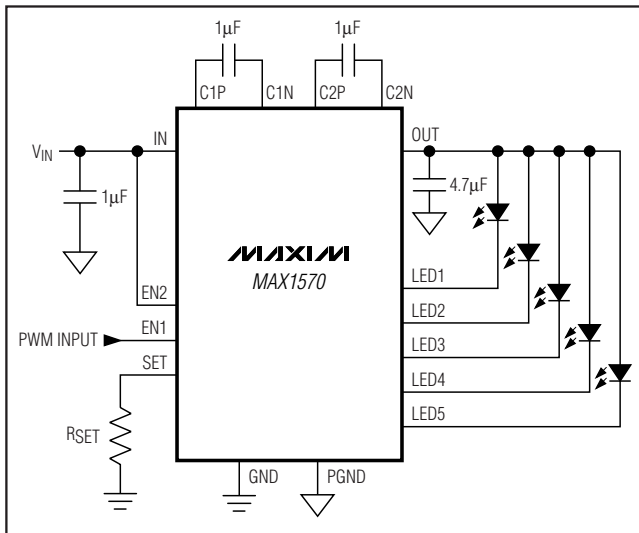

Figure 1. Dimming Using PWM Signal into EN1

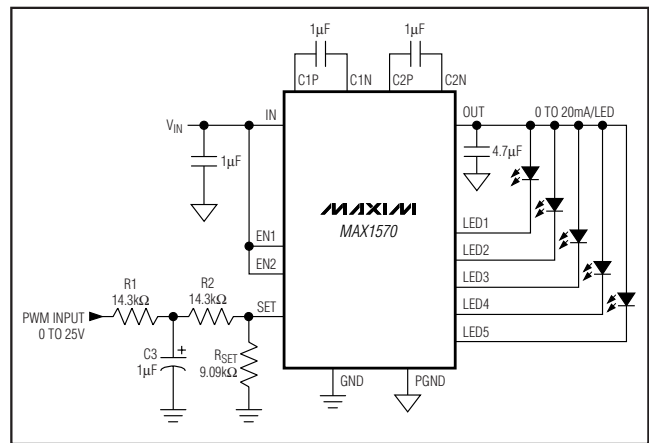

Figure 2. Dimming Using Filtered-PWM Signal

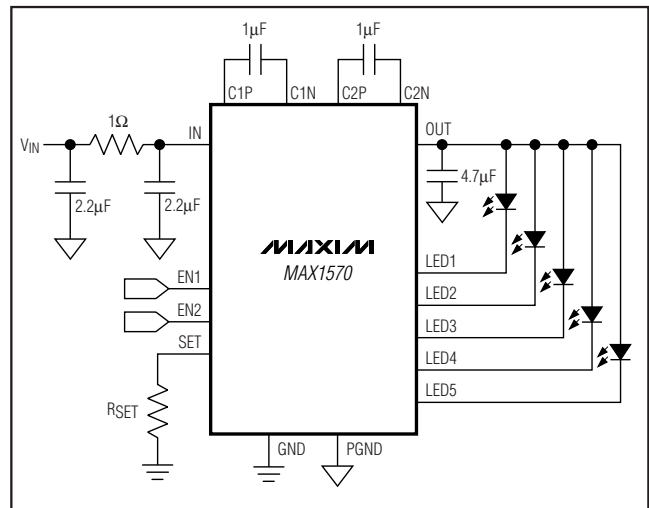

Figure 3. C-R-C Filter Reduces Input Ripple

Chip Information

TRANSISTOR COUNT: 3187

White LED Current Regulator with 1x/1.5x High-Efficiency Charge Pump

Package Information

(The package drawing(s) in this data sheet may not reflect the most current specifications. For the latest package outline information, go to www.maxim-ic.com/packages.)

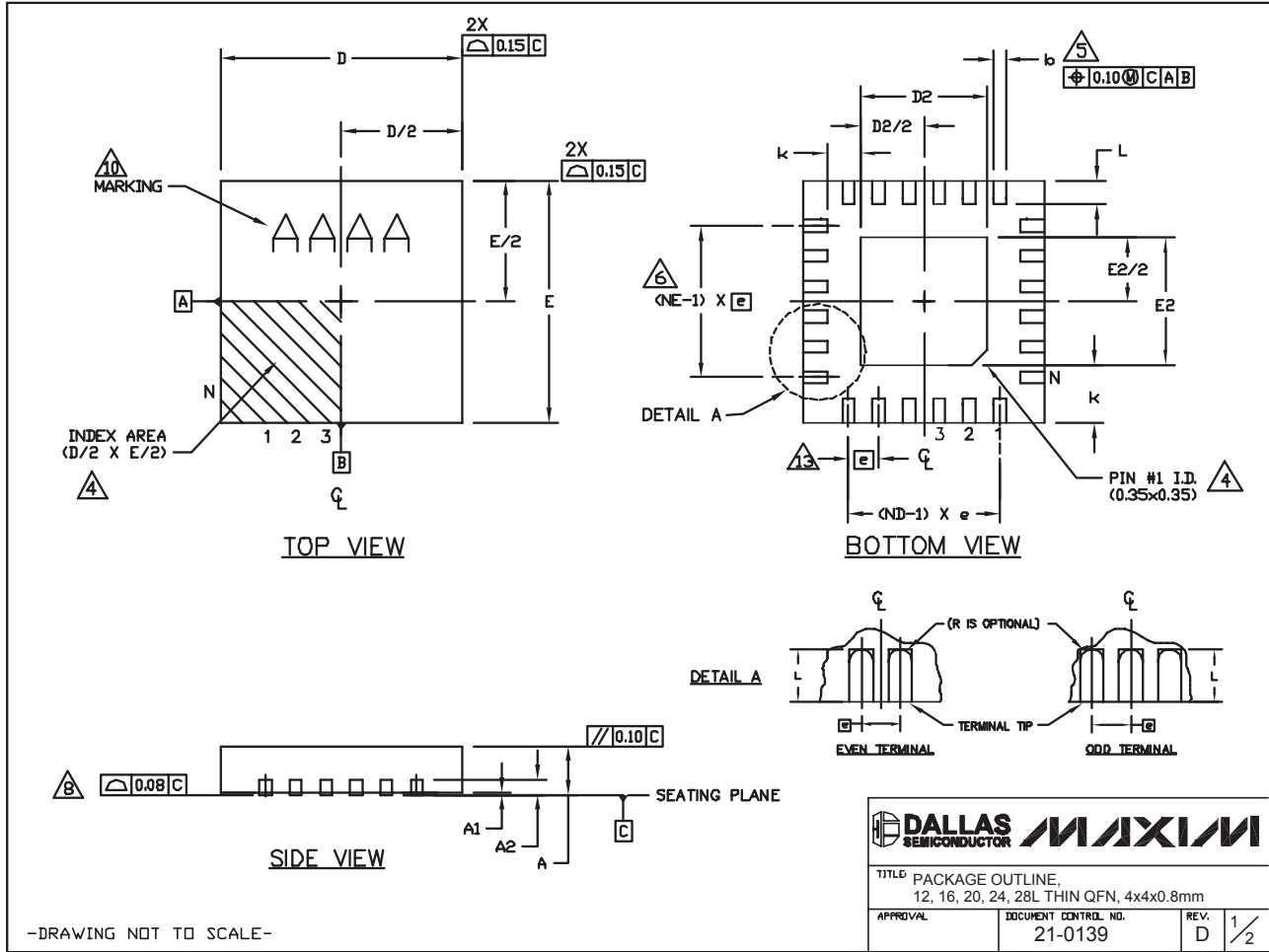

White LED Current Regulator with 1x/1.5x High-Efficiency Charge Pump

Package Information (continued)

(The package drawing(s) in this data sheet may not reflect the most current specifications. For the latest package outline information, go to www.maxim-ic.com/packages.)

MAX1570

COMMON DIMENSIONS															
PKG	12L 4x4			16L 4x4			20L 4x4			24L 4x4			28L 4x4		
REF.	MIN.	NOM.	MAX.	MIN.	NOM.	MAX.	MIN.	NOM.	MAX.	MIN.	NOM.	MAX.	MIN.	NOM.	MAX.
A	0.70	0.75	0.80	0.70	0.75	0.80	0.70	0.75	0.80	0.70	0.75	0.80	0.70	0.75	0.80
A1	0.0	0.02	0.05	0.0	0.02	0.05	0.0	0.02	0.05	0.0	0.02	0.05	0.0	0.02	0.05
A2	0.20 REF			0.20 REF			0.20 REF			0.20 REF			0.20 REF		
b	0.25	0.30	0.35	0.25	0.30	0.35	0.20	0.25	0.30	0.18	0.23	0.30	0.15	0.20	0.25
D	3.90	4.00	4.10	3.90	4.00	4.10	3.90	4.00	4.10	3.90	4.00	4.10	3.90	4.00	4.10
E	3.90	4.00	4.10	3.90	4.00	4.10	3.90	4.00	4.10	3.90	4.00	4.10	3.90	4.00	4.10
e	0.80 BSC.			0.65 BSC.			0.50 BSC.			0.50 BSC.			0.40 BSC.		
k	0.25	-	-	0.25	-	-	0.25	-	-	0.25	-	-	0.25	-	-
L	0.45	0.55	0.65	0.45	0.55	0.65	0.45	0.55	0.65	0.30	0.40	0.50	0.30	0.40	0.50
N	12			16			20			24			28		
ND	3			4			5			6			7		
NE	3			4			5			6			7		
JeDEC Var.	VGGB			VGGC			WGGD-1			WGGD-2			WGGE		

EXPOSED PAD VARIATIONS							
PKG CODES	D2			E2			DOWN BONDS ALLOWED
	MIN.	NOM.	MAX.	MIN.	NOM.	MAX.	
T1244-2	1.95	2.10	2.25	1.95	2.10	2.25	NO
T1244-3	1.95	2.10	2.25	1.95	2.10	2.25	YES
T1244-4	1.95	2.10	2.25	1.95	2.10	2.25	NO
T1644-2	1.95	2.10	2.25	1.95	2.10	2.25	NO
T1644-3	1.95	2.10	2.25	1.95	2.10	2.25	YES
T1644-4	1.95	2.10	2.25	1.95	2.10	2.25	NO
T2044-1	1.95	2.10	2.25	1.95	2.10	2.25	NO
T2044-2	1.95	2.10	2.25	1.95	2.10	2.25	YES
T2044-3	1.95	2.10	2.25	1.95	2.10	2.25	NO
T2444-1	2.45	2.60	2.63	2.45	2.60	2.63	NO
T2444-2	1.95	2.10	2.25	1.95	2.10	2.25	YES
T2444-3	2.45	2.60	2.63	2.45	2.60	2.63	YES
T2444-4	2.45	2.60	2.63	2.45	2.60	2.63	NO
T2844-1	2.50	2.60	2.70	2.50	2.60	2.70	NO

NOTES:

- DIMENSIONING & TOLERANCING CONFORM TO ASME Y14.5M-1994.
- ALL DIMENSIONS ARE IN MILLIMETERS. ANGLES ARE IN DEGREES.
- N IS THE TOTAL NUMBER OF TERMINALS.
- THE TERMINAL #1 IDENTIFIER AND TERMINAL NUMBERING CONVENTION SHALL CONFORM TO JEDEC 95-1 SPP-012. DETAILS OF TERMINAL #1 IDENTIFIER ARE OPTIONAL, BUT MUST BE LOCATED WITHIN THE ZONE INDICATED. THE TERMINAL #1 IDENTIFIER MAY BE EITHER A MOLD OR MARKED FEATURE.
- DIMENSION b APPLIES TO METALLIZED TERMINAL AND IS MEASURED BETWEEN 0.25 mm AND 0.30 mm FROM TERMINAL TIP.
- ND AND NE REFER TO THE NUMBER OF TERMINALS ON EACH D AND E SIDE RESPECTIVELY.
- DEPOPULATION IS POSSIBLE IN A SYMMETRICAL FASHION.
- COPLANARITY APPLIES TO THE EXPOSED HEAT SINK SLUG AS WELL AS THE TERMINALS.
- DRAWING CONFORMS TO JEDEC MO220, EXCEPT FOR T2444-1, T2444-3, T2444-4 AND T2844-1.
- MARKING IS FOR PACKAGE ORIENTATION REFERENCE ONLY.
- COPLANARITY SHALL NOT EXCEED 0.08mm
- WARPAGE SHALL NOT EXCEED 0.10mm
- LEAD CENTERLINES TO BE AT TRUE POSITION AS DEFINED BY BASIC DIMENSION "e", ±0.05.

-DRAWING NOT TO SCALE-

		
TITLE: PACKAGE OUTLINE, 12, 16, 20, 24, 28L THIN QFN, 4x4x0.8mm		
APPROVAL	DOCUMENT CONTROL NO.	REV. D
	21-0139	2/2

Maxim cannot assume responsibility for use of any circuitry other than circuitry entirely embodied in a Maxim product. No circuit patent licenses are implied. Maxim reserves the right to change the circuitry and specifications without notice at any time.

Maxim Integrated Products, 120 San Gabriel Drive, Sunnyvale, CA 94086 408-737-7600

11