

#### DESCRIPTION

The GLF81311 is an ultra-efficiency, 3 A rated, Load Switch with integrated slew rate control. The best-in-class efficiency makes it an ideal choice for use in IoT, mobile, and wearable electronics.

The GLF81311 features ultra-efficient I<sub>Q</sub>Smart™ technology that supports the lowest quiescent current (I<sub>Q</sub>) and shutdown current (I<sub>SD</sub>) in the industry. Low I<sub>Q</sub> and I<sub>SD</sub> solutions help designers to reduce parasitic leakage current, improve system efficiency, and increase battery lifetime.

The GLF81311 integrated slew rate control can also enhance system reliability by mitigating bus voltage swings during switching events. Where uncontrolled switches can generate high inrush currents that result in voltage droop and/or bus reset events, the GLF slew rate control specifically limits inrush currents during turn-on to minimize voltage droop.

GLF81311 Load Switch devices support an industry leading wide input voltage range and helps to improve operating life and system robustness. Furthermore, one device can be used in multiple voltage rail applications which helps to simplify inventory management and reduce operating cost.

#### FEATURES

- Supply Voltage Range: 2.0 V to 6.5 V  
7.0 V<sub>Abs</sub> max
- I<sub>OUT</sub> Max: 3 A
- Low R<sub>ON</sub>: 41 mΩ Typ @ 6.5 V<sub>IN</sub>
- Ultra-Low I<sub>Q</sub>: 10 nA Typ @ 6.5 V<sub>IN</sub>
- Ultra-Low I<sub>SD</sub>: 20 nA Typ @ 6.5 V<sub>IN</sub>
- Controlled Rise Time: 2.3 ms at 6.0 V<sub>IN</sub>
- Smart Enable Pin  
I<sub>EN</sub>: 3 nA Typ at V<sub>EN</sub> > V<sub>IH</sub>  
R<sub>EN</sub>: 500 kΩ Typ at V<sub>EN</sub> < V<sub>IL</sub>
- Integrated Output Discharge Switch
- Wide Operating Temperature Range:  
-40 °C ~ 85 °C
- HBM: 6 kV, CDM: 2 kV

#### APPLICATIONS

- Smart IoT Devices
- Low Power Subsystems

#### PACKAGE

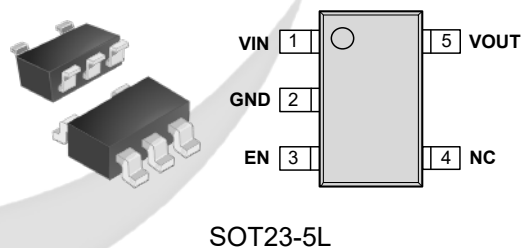

**PACKAGE OUTLINE**

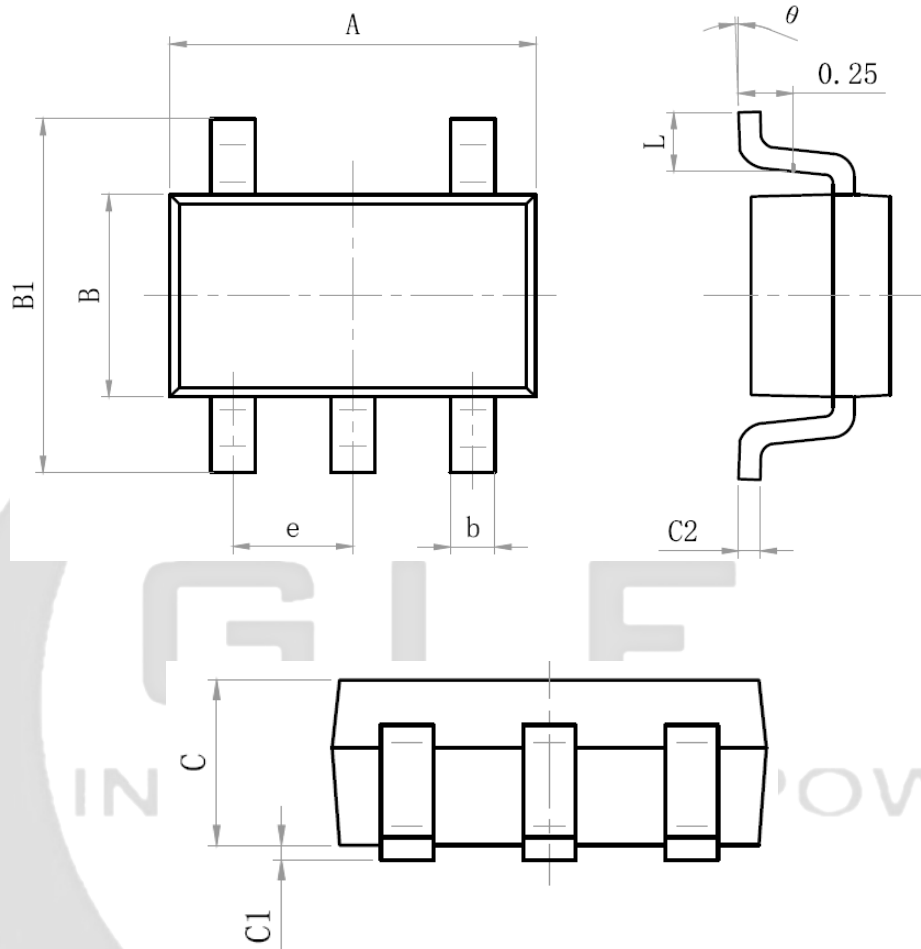

Size Mark	Min (mm)	Max (mm)	Size Mark	Min (mm)	Max (mm)
A	2.82	3.02	C	1.05	1.15
e	0.95 (BSC)		C1	0.03	0.15
b	0.28	0.45	C2	0.12	0.23
B	1.50	1.70	L	0.35	0.55
B1	2.60	3.00	θ	0°	8°

**TAPE AND REEL INFORMATION**

**REEL DIMENSIONS**

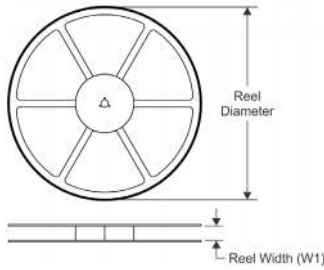

**QUADRANT ASSIGNMENTS PIN 1 ORIENTATION TAPE**

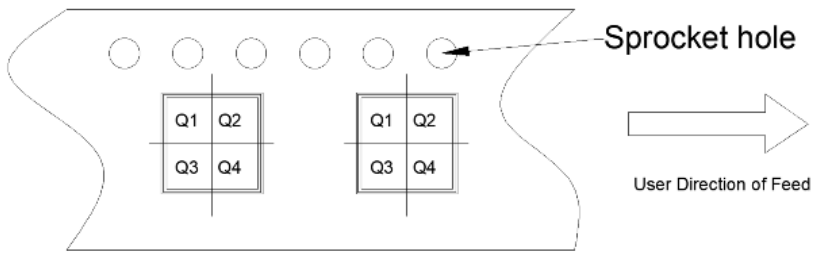

**TAPE DIMENSIONS**

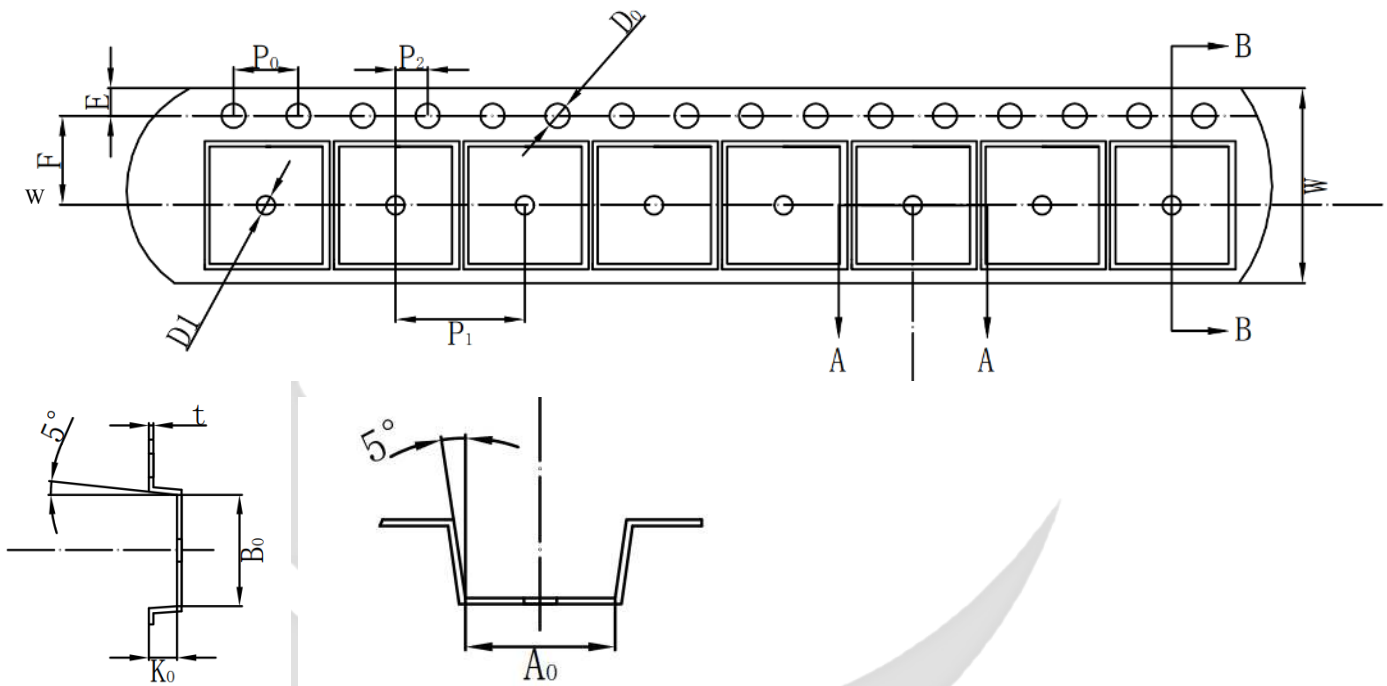

Device	Package	Pins	SPQ	Reel Diameter(mm)	Reel Width W1	A0	B0	K0	P1	W	Pin1
GLF81311	SOT23-5	5	3000	178	9	3.25	3.30	1.38	4	8	Q3

Remark:

- A0: Dimension designed to accommodate the component width
- B0: Dimension designed to accommodate the component length
- C0: Dimension designed to accommodate the component thickness
- W: Overall width of the carrier tape
- P1: Pitch between successive cavity centers