

THIS DRAWING IS UNPUBLISHED. RELEASED FOR PUBLICATION
 © COPYRIGHT - By TE CONNECTIVITY ALL RIGHTS RESERVED.

REVISIONS					
P	LTR	DESCRIPTION	DATE	DWN	APVD
P1		DRAWING CLARIFICATION	05MAR2020	SE	PKS

- 1 CONTINUOUS STRIP ON REELS WITH TERMINALS LOCATED ON 5.59±0.08 [.220±.003] CENTERS.
- 2 SLOT ACCEPTS 0.45-0.64mm [#25-#22] AWG COPPER MAGNET WIRE. TWO WIRES OF THE SAME SIZE PER SLOT EXCEPT 0.64 [#22] AWG WHICH IS ONE WIRE ONLY. OR 0.57-0.72mm [#23-#21] AWG ALUMINUM MAGNET WIRE, SINGLE WIRE ONLY ALUMINIUM WIRE RANGE IS APPLICABLE FOR POST TIN PLATED PART NUMBERS ONLY.
- 3 POKE-IN ACCEPTS A 0.50-0.90mm [#20-#18] AWG SOLID OR FUSED STRANDED LEAD WIRE.
- 4 MEASURE WHEN FREE STATE IS COMPRESSED TO 2.95 [.116] MAX.
- 5 TIN PLATE.
- 6 FOR SUPPLY WITHIN BRAZIL ONLY.

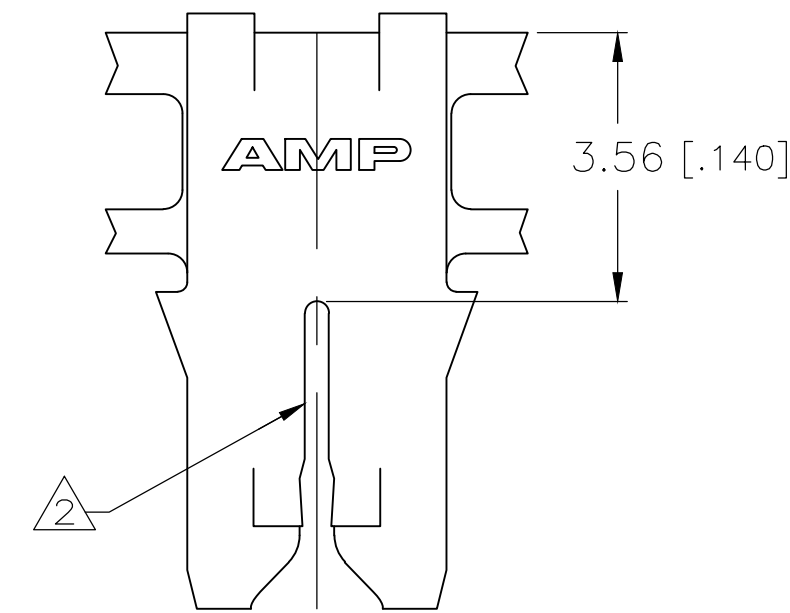
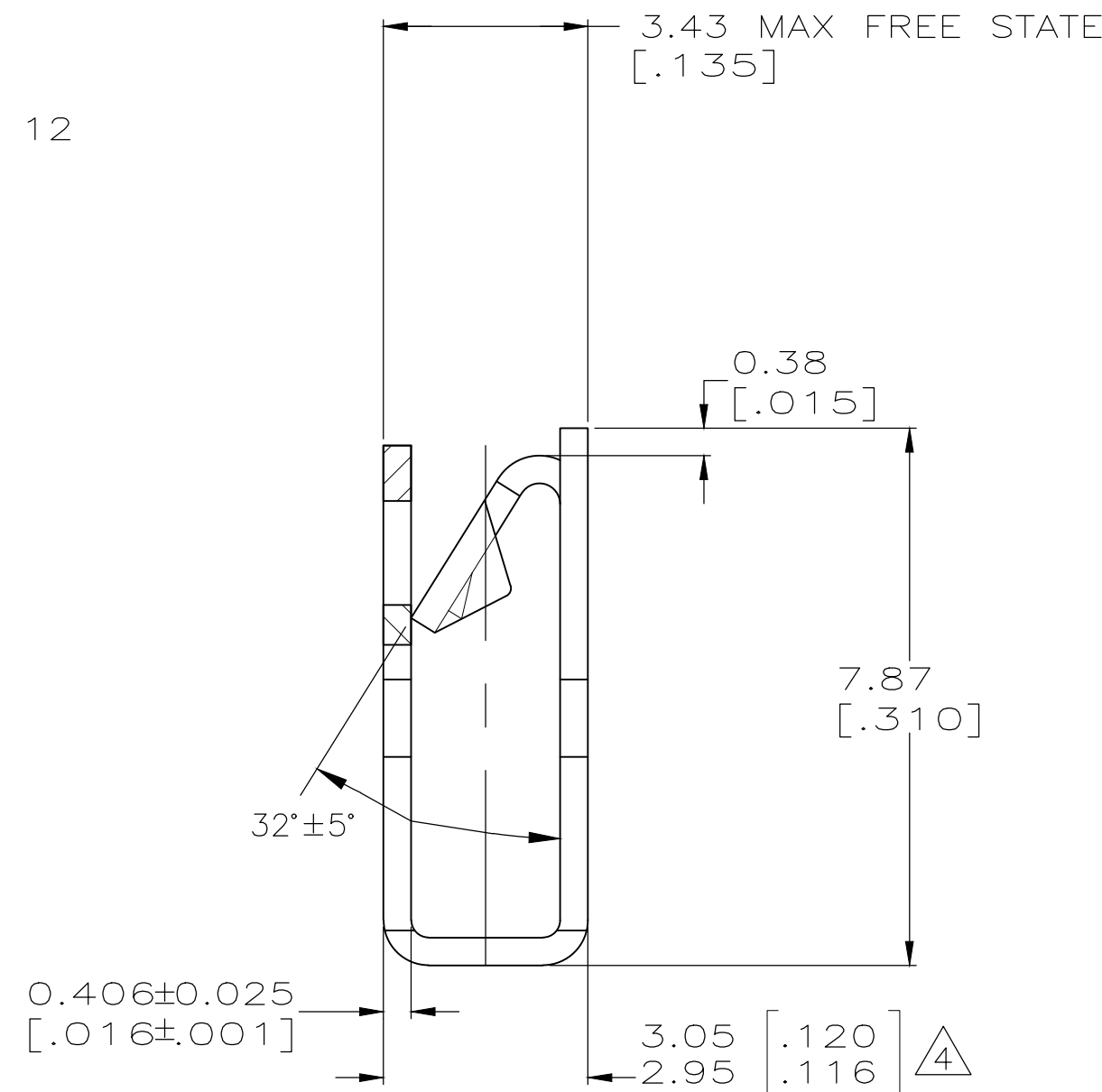
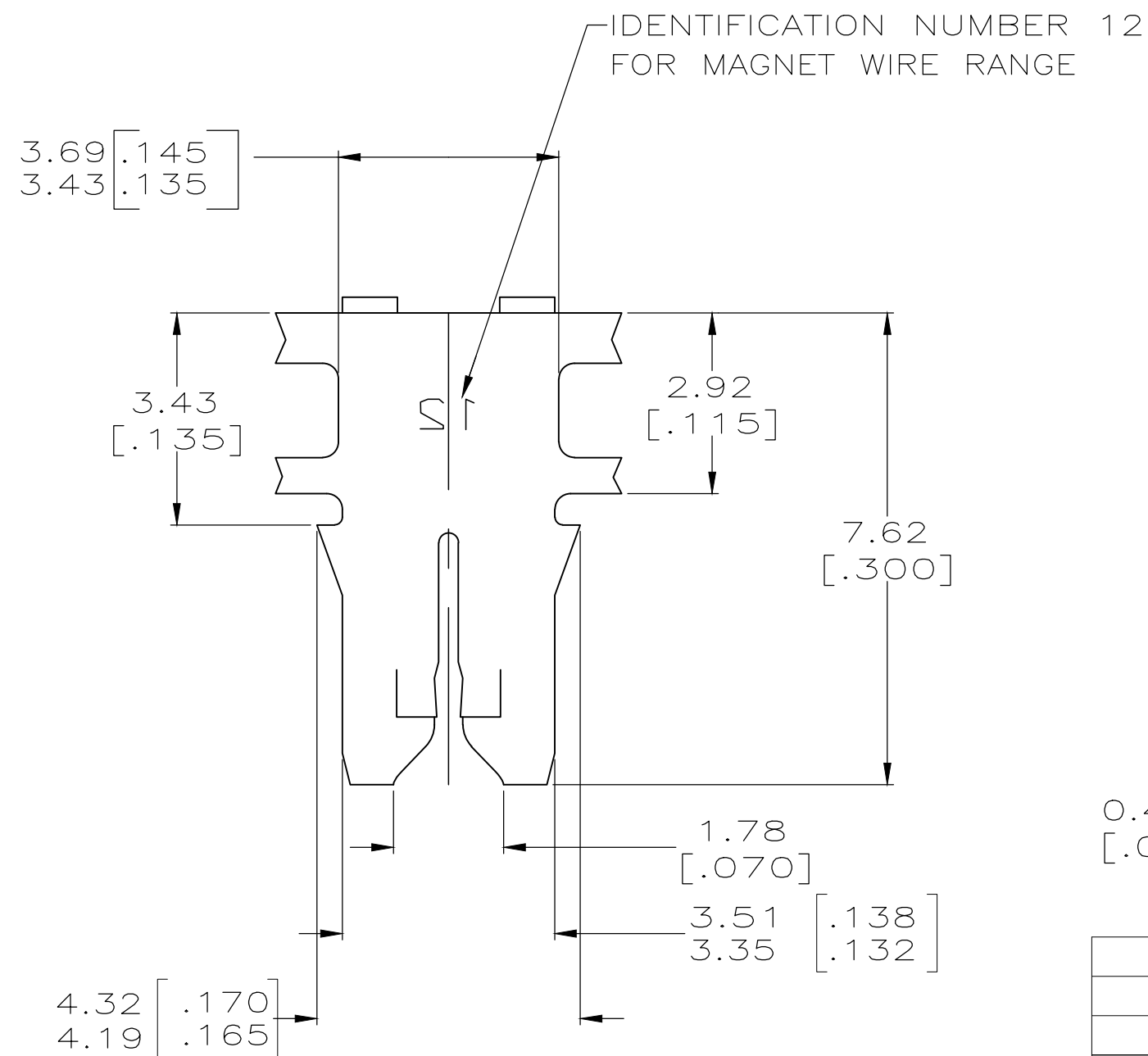
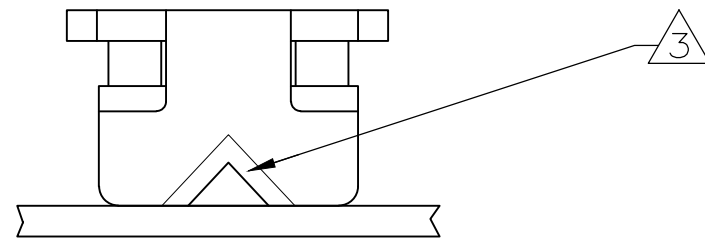

MATERIAL	REELING DIRECTION	SPLICE	REELING MATERIAL	FINISH	PART NUMBER
BRASS	STANDARD	PAPER SPLICE	WITH PAPER	5	63658-9
CU-NI-SI	STANDARD	PAPER SPLICE	WITHOUT PAPER EXCEPT IN SPLICE AREAS	5	63658-8
BRASS	STANDARD	PAPER SPLICE	NON RETURNABLE PLASTIC REEL WITH PAPER	UNPLATED	63658-7
BRASS	STANDARD	PAPER SPLICE	PLASTIC REEL WITH PAPER	5 6	63658-6
PHOSPHOR BRONZE	STANDARD	PAPER SPLICE	WITHOUT PAPER EXCEPT IN SPLICE AREAS	5	63658-5
BRASS	STANDARD	PAPER SPLICE	PLASTIC REEL WITH PAPER	UNPLATED	63658-4
BRASS	REVERSE	PAPER SPLICE	WITHOUT PAPER EXCEPT IN SPLICE AREAS	5	63658-3
BRASS	STANDARD	SPLICE FREE	PLASTIC REEL WITHOUT PAPER	5	63658-2
BRASS	STANDARD	PAPER SPLICE	WITHOUT PAPER EXCEPT IN SPLICE AREAS	5	63658-1

THIS DRAWING IS A CONTROLLED DOCUMENT.

DWN	L.A.MAYER	8-10-92
CHK	M.S.FEHER	8-11-92
APVD	TL SHUTTER	8-11-92

TE Connectivity

TERMINAL, POKE-IN
300 SERIES MAG-MATE

SIZE	CAGE CODE	DRAWING NO	RESTRICTED TO
A2	00779	C-63658	-

CUSTOMER DRAWING SCALE 10:1 SHEET 1 OF 1 REV P1