

144-pin LQFP



22 mm

22 mm

IC dimensions

(pin-to-pin nominal)

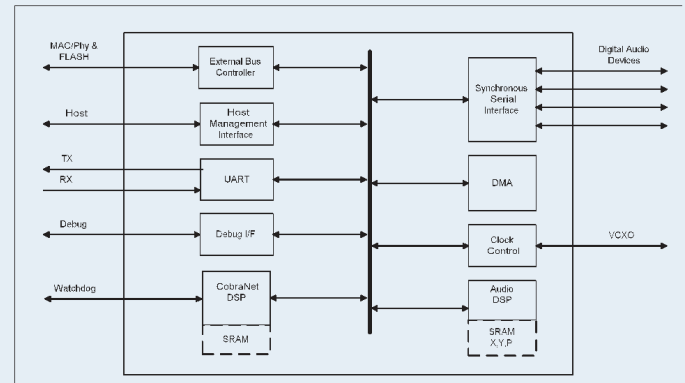

CS4961xx

## New Audio System Processors are Ideal for Digital Audio Networking Applications

### Highly Integrated Family Combines CobraNet Interface with Powerful Audio DSP Engine to Dramatically Reduce Overall Audio System Costs

#### CS4961xx

The new CS4961xx family of ICs integrates Cirrus Logic's highly regarded audio digital signal processor (DSP) with Cirrus Logic's award-winning CobraNet™ technology, which is the leading standard for delivering real-time, uncompressed digital audio over Ethernet networks. The results are highly optimized audio system processors that offer dramatic system cost savings and enhanced audio processing features for manufacturers of professional, commercial and consumer networked-audio products.

The CS4961xx audio system processors, which include the CS496102, the CS496112 and the

CS496122, reduce system costs because they allow for the removal of a separate, dedicated audio DSP on the board design. This 32-bit fixed-point DSP core features 120 MIPS for custom programming and these three ICs provide 2, 8 or 16 simultaneous channels of audio input and output at up to 96 kHz sample rates. They also provide multiple 16, 20 or 24-bit audio connections across an Ethernet network. In fact, two-way audio control and monitoring is possible at any point along the network.

Featuring a high-speed parallel host port interface, the CS4961xx allows optional

connection to a host processor as well as offering Ethernet-based control, monitoring, and management via industry standard SNMP. Firmware can be easily updated over Ethernet using TFTP or via the host interface. Additional control and monitoring functions are also provided by the innovative, built-in asynchronous and packet-bridge functions.

The ICs are designed to expand the market for CobraNet-enabled networked digital audio products such as power amplifiers, mixers, signal processors, intercom systems, ceiling speakers, loudspeakers, paging systems, and high-end networked consumer audio gear.

#### CS4961xx FEATURES

- Combines CobraNet technology with a powerful 32-bit DSP core
- Integration reduces overall system costs
- Simplifies overall system design effort
- 2x2, 8x8, 16x16 channel ICs
- Supports 48 kHz and up to 96 kHz sample rates
- Selectable latency of 1.33, 2.66, or 5.33 ms across network
- 32-bit synchronous serial digital audio I/O
- Parallel host control
- Asynchronous serial control transport
- Available in 144-pin LQFP
  - 120 MIPS DSP on programmable core
  - Audio may be processed from network or local inputs and sent to local outputs or to the network

#### SOFTWARE DEVELOPMENT KIT

- Full-featured DSP assembler and linker
- Includes Cirrus Logic's DSP Conductor™ software, a graphical audio-oriented development environment, for easy adjustments to DSP Parameters
- Integrated target management and code download
- Real-time control of DSP parameters over the audio network
- Example DSP code and tutorials
- Microkernel handles all audio I/O and DSP parameter control

#### COBRANET TECHNOLOGY ADVANTAGES

- Available as low-cost ICs without licensing or royalty fees
- CobraNet technology can coexist with data traffic over existing Ethernet networks, saving money by eliminating additional infrastructure costs
- De-facto industry standard with tens-of-thousands of installed nodes in high-profile "mission-critical" venues worldwide
- Networked audio, control and monitoring (bi-directional)
- Uses SNMP for control and monitoring (computer-network friendly)
- Incorporates multiple fault-tolerant features
- Ability to send audio from any CobraNet interface to any other – unlimited addressing, unlimited capacity

## Software Tools – DSP Programming

- Assembler and Linker – Full featured assembler and linker supports modular development for Cirrus Logic's high performance Harvard-architecture DSP processor.
- Using Cirrus Logic's DSP Conductor™ software, a graphical audio-oriented development environment, the developer defines signal flow and may make real-time adjustments to DSP parameters. Software interacts with the target system via an Ethernet connection.
- Documentation – The SDK includes comprehensive documentation of the Instruction Set Architecture (ISA) and the operation of the Assembler, Linker and DSP Conductor software. Example code and tutorials get you started quickly writing your own application specific DSP code.
- Support – The CobraNet technology SDK is supported by experienced audio DSP and CobraNet technology engineers as well as Cirrus Logic FAEs.

## Application Examples

- Facility audio distribution
- Paging stations
- Power amplifiers
- Intercoms
- Audio snakes
- Signal processors
- Mixing consoles
- Self-powered loudspeakers
- Ceiling speakers
- Microphone pre-amplifiers
- Media servers
- Stand-alone A/D and D/A interfaces
- Networked consumer audio

## Software Tools – Networking

The Silicon Series of processors, along with the included firmware, implements a fully functional CobraNet technology-compliant interface. In addition, Cirrus Logic offers a variety of utility programs and documentation support to assist our developers in successfully creating and launching CobraNet technology based products.

- CobraCAD – is an application used to model CobraNet network topologies. Simply point, click, drag, and drop and CobraCad will verify that the CobraNet network configuration will perform as intended. This tool is ideal for end users installing systems with CobraNet technology.
- CobraNet Discovery – is a utility program used to provide valuable feedback regarding the working state of a CobraNet network. The program reads and displays operational statistics from every CobraNet interface on the network. It can also be used to assign addresses to individual CobraNet devices and to update CobraNet firmware.
- CobraNet Object Tools (COT) – is a Microsoft® COM object library that can be

used with a variety of software languages or scripting systems. COT provides all of the low-level functionality needed to configure and monitor CobraNet devices, greatly easing the development effort required to write custom CobraNet applications.

- Other Resources – Cirrus Logic has additional software tools available for use in manufacturing and test environments. Reference designs and many helpful application notes are also available.

The CobraNet Silicon Series processors and its firmware and software tools are available today with the full support that comes from the worldwide Cirrus Logic sales and applications engineering teams.

CobraNet technology has a proven track record, with years of successful deployments and tens-of-thousands of nodes in use today. This solid track record, along with the cost-effective CobraNet Silicon Series of processors now available, makes the selection of CobraNet technology an easier choice than ever.

**connected by**  
**CobraNet™**

Part No.	Serial Audio In	Serial Audio Out
CS496102	2	2
CS496112	8	8
CS496122	16	16

\* These ICs can be made available in lead-free packaging and/or industrial grade.

[www.cirrus.com](http://www.cirrus.com)

Cirrus Logic, Inc. · 2901 Via Fortuna · Austin TX 78746 USA · T 512-851-4000 · T 800-888-5016 · F 512-851-4977

Product Bulletin 0159-0205-PB-LP ©2005 Cirrus Logic, Inc. All rights reserved. Product information is subject to change without notice. Cirrus Logic, CobraNet, and Leading the Digital Entertainment Revolution are trademarks of Cirrus Logic, Inc. Other brand and product names may be trademarks or service marks of their respective owners.