

CBTL06GP212

High performance DisplayPort switch with high common-mode voltage support

Rev. 1 — 2 May 2012

Product brief

1. General description

The CBTL06GP212 is a six-channel ('hex') multiplexer for DisplayPort and PCI Express applications at Generation 2 ('Gen2') speeds. It provides four differential channels capable of 1 : 2 switching or 2 : 1 multiplexing (bidirectional and AC-coupled) PCI Express or DisplayPort signals, using high-bandwidth pass-gate technology. It provides support for high common-mode/bias voltage on the high speed differential channels. Additionally, it provides for switching/multiplexing of the Hot Plug Detect signal as well as the AUX or DDC (Direct Display Control) signals, for a total of six channels on the display side. The AUX and DDC channels provide a four-position multiplexer such that an additional level of multiplexing can be accomplished when AUX and DDC I/Os are on separate pins of the display source device.

The CBTL06GP212 is designed for Gen2 speeds, at 5.0 Gbit/s for PCI Express or 5.4 Gbit/s for DisplayPort. It consumes 2 mA current (typical) in operational mode and provides a shutdown function to support battery-powered applications.

A typical application of CBTL06GP212 is on motherboards where one of two GPU display sources needs to be selected to connect to a display sink device or connector. A controller chip selects which path to use by setting a select signal HIGH or LOW. Due to the non-directional nature of the signal paths (which use high-bandwidth pass gate technology), the CBTL06GP212 can also be used in the reverse topology, e.g., to connect one display source device to one of two display sink devices or connectors.

2. Features

- 1 : 2 switching or 2 : 1 multiplexing of DisplayPort (v1.2 - 5.4 Gbit/s) or PCI Express (v2.0 - 5.0 Gbit/s) signals
 - ◆ 4 high-speed differential channels with 2 : 1 muxing/switching for DisplayPort or PCI Express signals
 - ◆ 1 channel with 4 : 1 muxing/switching for AUX at 1 Mbit/s or DDC signals
 - ◆ 1 channel with 2 : 1 muxing/switching for single-ended HPD signal
- High-bandwidth analog pass-gate technology
- Supports a wide range of common-mode/bias voltage on high speed differential channels
- Supports high-speed signal switching over a wide common-mode range and differential swing
- R_{ON} on DP high-speed channels: 6 Ω
- Low insertion loss:
 - ◆ -0.5 dB at 100 MHz
 - ◆ -1.5 dB at 1.35 GHz
 - ◆ -2.5 dB at 2.7 GHz
- Low crosstalk: -35 dB at 2.7 GHz
- Low off-state isolation: -30 dB at 2.7 GHz
- Low return loss: -8 dB at 2.7 GHz
- Very low intra-pair skew (5 ps typical)
- Very low inter-pair skew (< 80 ps)
- 3 dB bandwidth at 5 GHz
- Switch/multiplexer position select CMOS input
- Shutdown mode CMOS input
- Supports backdrive protection
- Single 3.3 V power supply

- Operation current of 2 mA typical, shut-down current 10 µA maximum
- ESD 2 kV HBM, 500 V CDM
- Available in 5 mm × 5 mm, 0.5 mm ball pitch TFBGA48 package

3. Applications

- Motherboard applications requiring DisplayPort and PCI Express switching/multiplexing
- Docking stations
- Notebook computers
- Chip sets requiring flexible allocation of PCI Express or DisplayPort I/O pins to board connectors

4. Ordering information

Table 1. Ordering information

Type number	Solder process	Package		
		Name	Description	Version
CBTL06GP212EE/G	Pb-free (SnAgCu solder compound)	TFBGA48	plastic thin fine-pitch ball grid array package; 48 balls; body 5 × 5 × 0.8 mm ^[1]	SOT918-1

[1] Total height including solder balls after printed circuit board mounting = 1.15 mm.

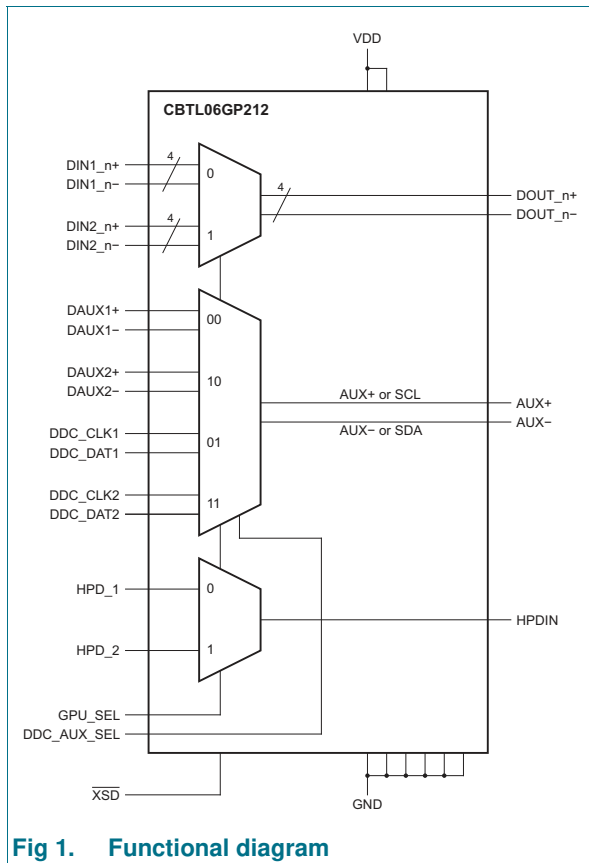

Fig 1. Functional diagram

© NXP B.V. 2012.

All rights reserved.

For more information, please visit: <http://www.nxp.com>
 For sales office addresses, please send an email to: salesaddresses@nxp.com

Date of release: 2 May 2012
 Document identifier: CBTL06GP212