

## Introduction

The SAM4C32 Evaluation Kit (SAM4C32-EK) enables evaluation capabilities and code development of applications running on the 32-bit ARM® Cortex®-M4 SAM4C series microcontrollers from Atmel® Corporation.

The SAM4C32-EK can be used with the following microcontrollers:

- SAM4C32C
- SAM4C16C
- SAM4C8C

This document describes the kit contents and architecture, and provides guidelines on how to use the kit.

## Kit Contents

---

- SAM4C32-EK Board
- Power Supply
  - Universal input AC/DC power supply with US, Europe and UK plug adapters
  - 3V Lithium Battery type CR1225
- Cables
  - Serial RS232 cable
  - Micro A/B-type USB cable
- Welcome letter

## Reference documents

---

- SAM4C Series Datasheet (Atmel literature No. 11102)

## Table of Contents

---

<b>1. SAM4C32-EK Specifications</b>	4
1.1 Battery	4
1.2 Recovery Procedure	4
<b>2. Power Up</b>	5
2.1 Power Up the Board	5
2.2 Sample Code and Technical Support	5
<b>3. SAM4C32-EK Hardware</b>	6
3.1 Overview	6
3.2 Equipment List	7
3.3 Function Blocks	9
3.4 Embedded Memories	11
3.5 Communication Interfaces	13
3.6 Debug Interfaces	15
3.7 Extend Interfaces	16
3.8 LCD Display	17
3.9 Analog I/O	20
3.10 CryptoAuthentication (optional)	21
3.11 LEDs and Buttons	22
3.12 Miscellaneous I/O	23
3.13 Metrology Core Serial Interface	23
3.14 PIO Usage	24
3.15 Connectors	26
<b>4. SAM4C32-EK Firmware Demonstration</b>	33
4.1 SAM4C32-EK Default Application	33
4.2 Measuring the Backup Mode Current Consumption on VDDBU	34
<b>5. SAM4C32-EK Design Files</b>	34
5.1 SAM4C32-EK Schematics	34
5.2 SAM4C32-EK Layout	42
<b>6. Revision History</b>	50

# 1. SAM4C32-EK Specifications

Table 1-1. SAM4C32-EK Specifications

Characteristic	Specifications
PCB	6 layers, 140 mm x 100 mm
PCB Material	Standard FR4 in 1.6 mm thickness
Clock Speed	Crystal 8 MHz Piezoelectric Ceramic Resonator 8.192 MHz 32.768 kHz external clock
Ports	RS232 RS485 USB
Memory	TWI EEPROM Serial Data Flash
Board Supply Voltage	5V DC from main connector power supply 5V DC from USB 3V Battery for Backup and RTC
ROHS	Compliant
CE and FCC Part 15 status	Compliant

 **CAUTION** ESD-Sensitive Electronic Equipment!



The SAM4C32-EK is shipped in a protective anti-static package. The board system must not be subjected to high electrostatic discharge.

We strongly recommend using a grounding strap or similar ESD protective device when handling the board in hostile ESD environments (offices with synthetic carpet, for example). Avoid touching the component pins or any other metallic element on the board.

## 1.1 Battery

The SAM4C32-EK ships with a 3V coin battery. This battery is not required for the board to start up as long as jumper JP8 is closed.

The coin battery is provided for user convenience in case the user would like to exercise the date and time backup function of the SAM4C32 devices when the board is switched off.

## 1.2 Recovery Procedure

The demo software is stored in internal Flash memory. If the content of the internal Flash has been erased, it can be reprogrammed recovered to the state as it was when shipped by Atmel using Atmel SAM-BA<sup>®</sup> In-system Programmer available on the Atmel website ([www.atmel.com](http://www.atmel.com)). The binary file of the demo software is also available on the Atmel website.

## 2. Power Up

### 2.1 Power Up the Board

Unpack the board taking care to avoid electrostatic discharge. Unpack the power supply, select the power plug adapter corresponding to that of your country, and insert it in the power supply.

Connect the power supply DC connector to the board and plug the power supply to an AC power plug. The board LCD should light up and display a graphic demo program.

### 2.2 Sample Code and Technical Support

After boot up, designers can run sample code or their own application on the development kit. Users can download sample code and get technical support from the Atmel website. The SAM4C32-EK is supported by the Atmel Software Framework (ASF) which is also available on the Atmel website.

### 3. SAM4C32-EK Hardware

#### 3.1 Overview

This section introduces the SAM4C32-EK design. It introduces system-level concepts, such as power distribution, memory, and interface assignments.

The Atmel SAM4C32 microcontroller is a system-on-chip solution for smart energy applications, built around two high-performance 32-bit ARM Cortex-M4 RISC processors. These devices operate at a maximum speed of 120 MHz and feature up to 2 Mbyte of embedded Flash, 256 Kbytes of SRAM and on-chip cache for each core.

The dual ARM Cortex-M4 architecture allows for integration of application layer, communications layers and security functions in a single device, with the ability to extend program and data memory via a 16-bit external bus interface. The peripheral set includes an advanced cryptographic engine, two anti-tamper pins with time-stamping function, floating point unit (FPU), five USARTs, two UARTs, two TWIs, up to seven SPIs, as well as a PWM timer, two 3-channel general-purpose 16-bit timers, temperature compensable low-power RTC running on backup area down to 0.5  $\mu$ A, and a 50 x 6 segmented LCD controller.

The SAM4C series is a scalable platform providing, alongside Atmel's industry leading SAM4 standard microcontrollers, unprecedented cost structure, performance and flexibility to smart meter designers worldwide.

Figure 3-1. SAM4C32-EK Board Architecture

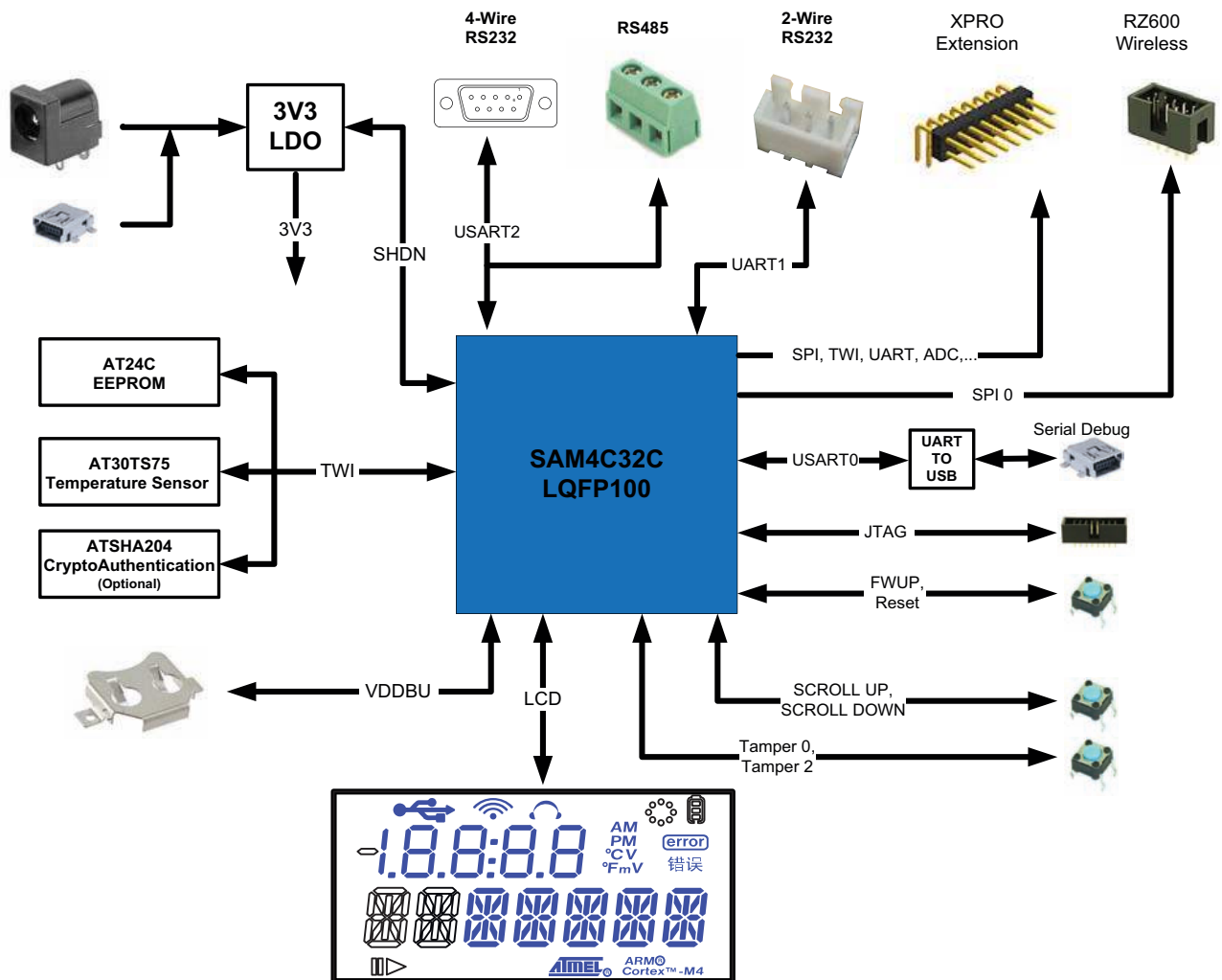

## 3.2 Equipment List

### 3.2.1 Features List

- CPU SAM4C32 with its embedded resources
  - 8 MHz and 32.768 kHz Quartz Crystal, SMB connector for external source
  - Main regulator 5V/3.3V with red LED indicator
  - Lithium Coin Cell Battery
- Main board with:
  - Custom segmented LCD
  - Shared interface RS232 / RS485
  - Serial data Flash SPI
  - Two-Wire Serial EEPROM
  - Two-Wire Temperature Sensor
  - Two-Wire CryptoAuthentication™ Memory (*optional*)
- Debug solution:
  - 2 peripheral Input/Output extension connectors HE10 (PIO A, B)
  - Peripheral Input/Output extension connector HE10 (PIO Sense)
  - JTAG/ICE interface
  - UART/USB bridge Device Communication interface
- Analog
  - Analog 3V reference
  - Potentiometer connected on ADC input
- Buttons
  - 4 system push buttons: Reset, Force Wake-Up, Tamper 0, Tamper 2
  - 2 user push buttons: Scroll Up and Scroll Down
- LEDs
  - Amber LED
  - Blue LED
  - Green LED

### 3.2.2 Interface Connection

The SAM4C32-EK board includes the following hardware interfaces:

- RS232/RS485 (USART0 RX, TX, RTS, CTS) connected to:
  - 9-way male D-type RS232 connector
  - 3-pin connector
- JTAG/SWD 20-pin IDC connector
- 5-pin Micro AB USB connector (bridge UART)
- 3 PIOs connected to HE10 connectors

Figure 3-2. Annotated SAM4C32-EK Board Layout

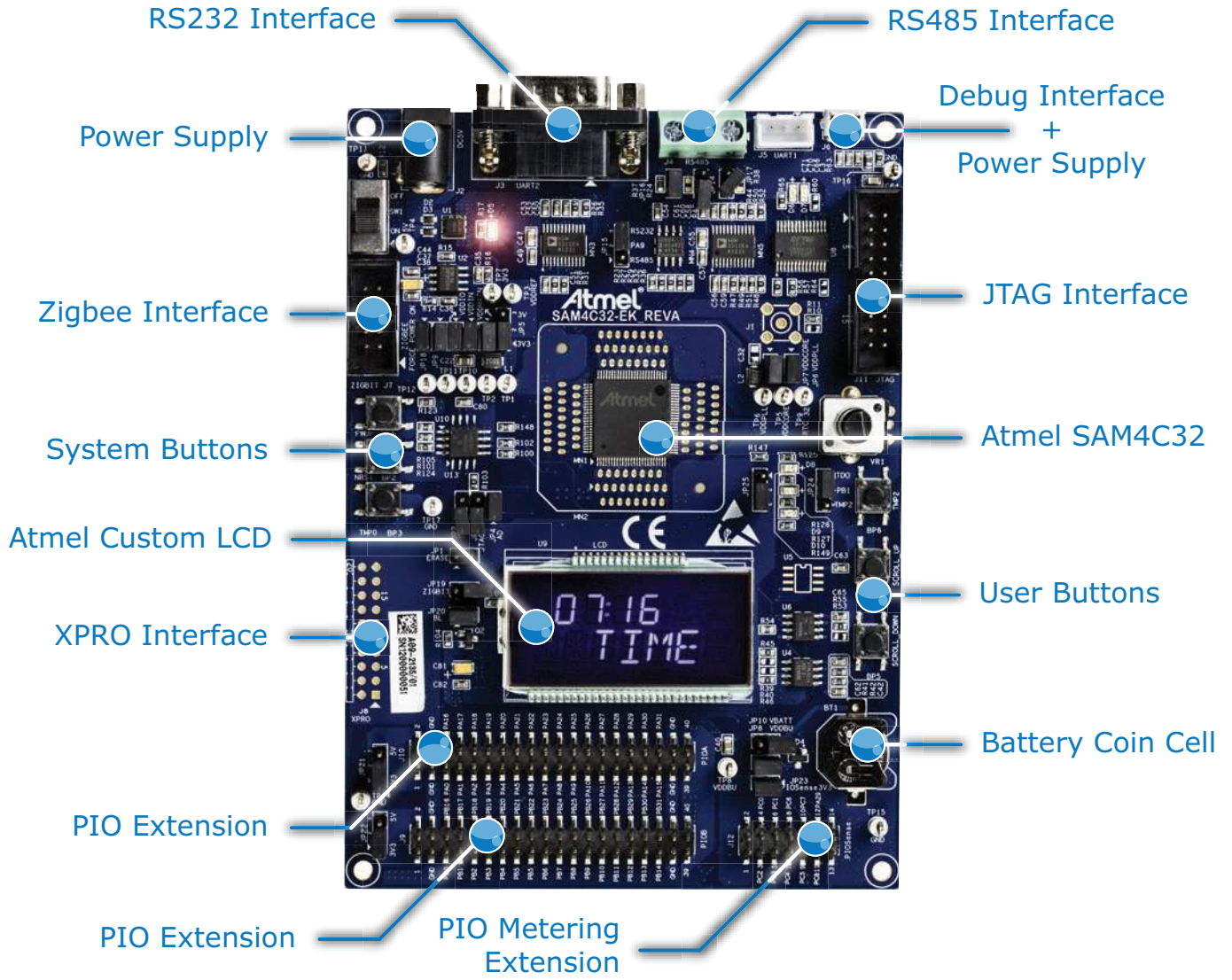



### 3.3 Function Blocks

#### 3.3.1 Processor

The SAM4C32-EK board is equipped with a SAM4C32 device in an LQFP100 package.

Figure 3-3. SAM4C32 Processor

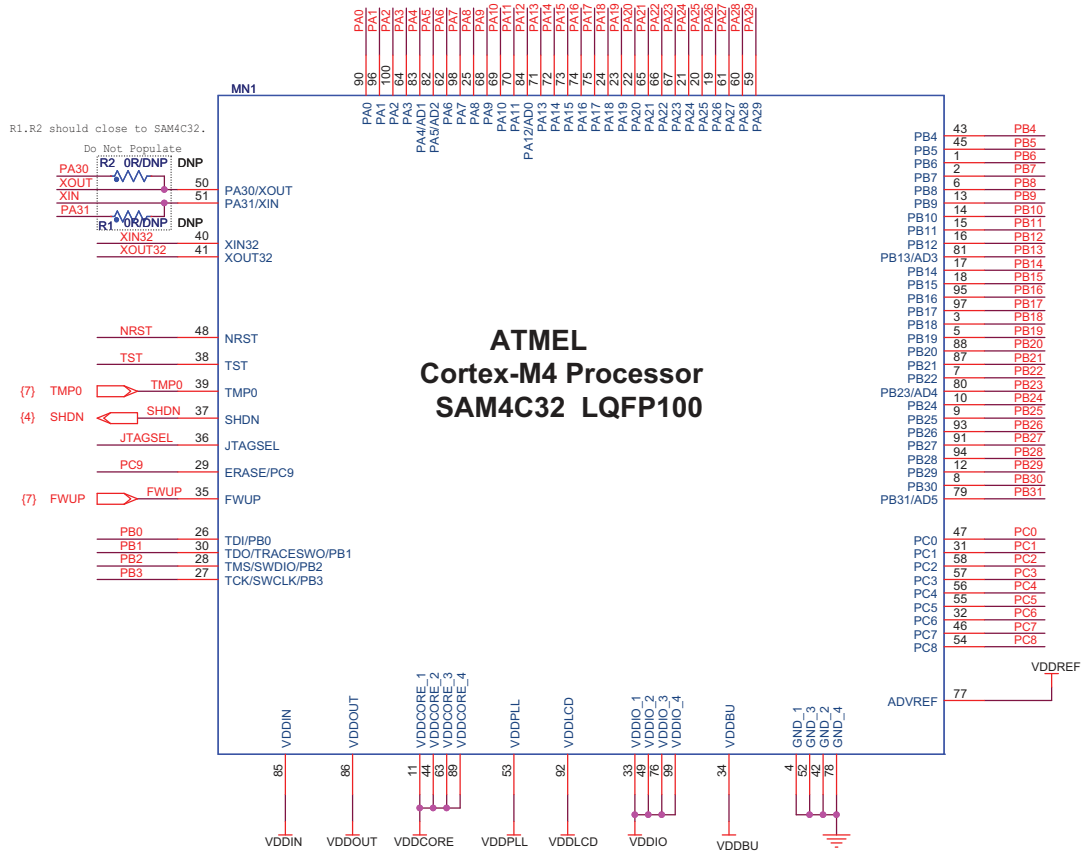

#### 3.3.2 Clock Distribution

The SAM4C32-EK board includes two clock systems (see Table 3-1 and Figure 3-4).

Table 3-1. Components Clock System

Qty	Description	Component Assignment
1	Crystal for Internal Clock 8 MHz	Y2
1	Crystal for RTC Clock 32.768 kHz	Y1

Figure 3-4. Clock System

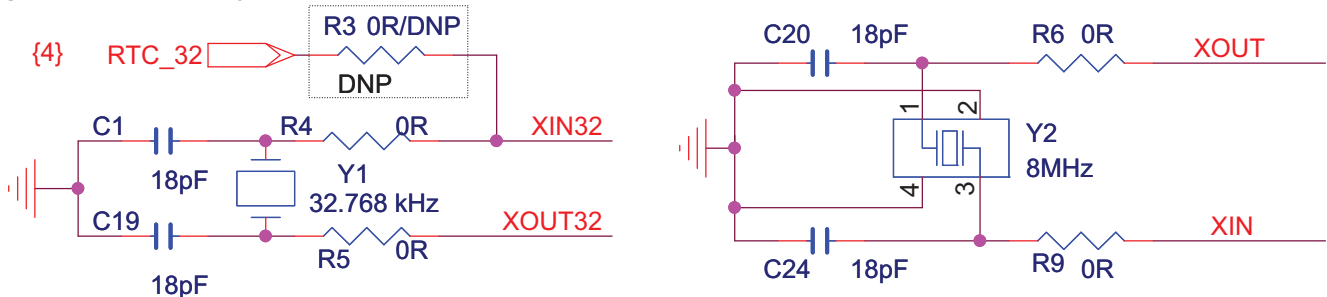

### 3.3.3 Reset and Wake-Up Circuitry

The reset sources for the EK board are:

- Power-on reset
- Push-button reset (refer to [Section 3.11.2 “Push Buttons”](#))
- JTAG reset from an in-circuit emulator

### 3.3.4 Power Supplies

The SAM4C32-EK board evaluation and development platform embeds all the necessary power rails required for the SAM4C32 processor and peripherals.

The SAM4C32-EK board can be supplied by either a 5V DC block through input J2 (see [Figure 3-5](#)) or a USB connection via J6 (refer to [“DBGU/USB Bridge Schematic” on page 15](#)).

A manual power supply selection switch (SW1) is provided to power on/off the main power line.

**Figure 3-5. Power Supply Schematic**

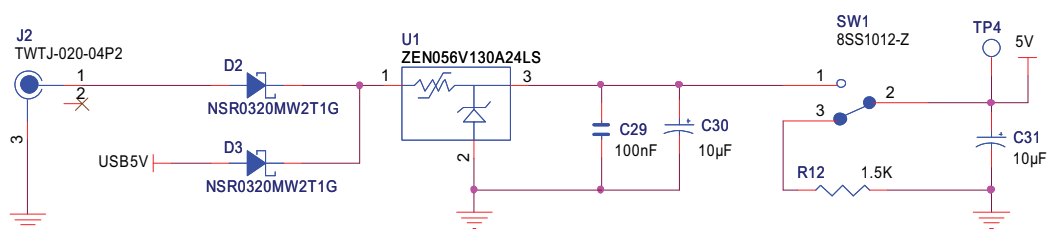

### 3.3.5 Power Rails

The SAM4C32 supports 1.6V–3.6V single supply mode (VDDIN). An internal regulator input is connected to the source and its output feeds VDDCORE (VDDOUT connected to VDDCORE).

When the 3.3V supply is present, the Power LED D5 is lit. Test points TP2 to TP5 are used to perform testing.

**Table 3-2. Power Supply Voltage Ranges**

Power Supply	Ranges	Comments
VDDIO	1.6V–3.6V	Flash Memory Charge Pumps Supply for Erase and Program Operations, and Read operation Input Output buffers Supply
VDDBU	1.6V–3.6V	Backup Area power supply. VDDBU is automatically disconnected when VDDIO is present (> 1.9V)
VDDIN	1.6V–3.6V	1.6V min. if LCD and ADC not used, 2.5V otherwise
VDDLCD	2.5V–3.6V	LCD Voltage Regulator Output External LCD power supply input (LCD regulator not used) VDDIO/VDDIN need to be supplied when the LCD Controller is used
VDDOUT	1.2V Output	120 mA Output Current
VDDPLL	1.08V–1.32V	–
VDDCORE	1.08V–1.32V	–

**Figure 3-6. Power Rails Schematic**

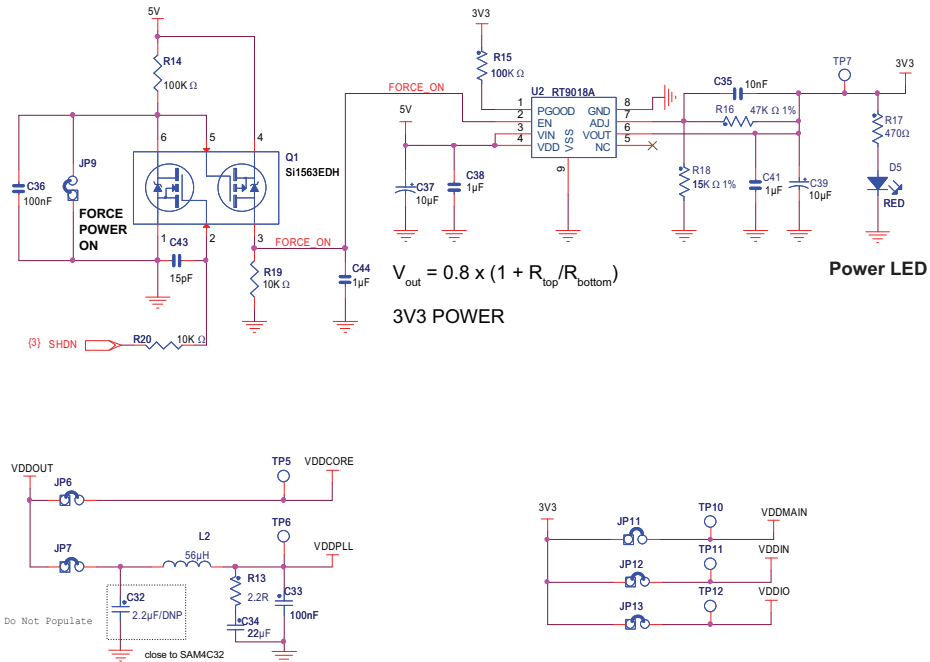

Note: Test points and jumpers are provided for easy access to each of the regulated power lines and measure the current on each line.

### 3.3.6 Battery Backup

The VDDBU pin is powered from the 3.3V rail or from a backup battery BT1 via a dual Schottky diode D4. Test points TP8 and jumper JP8/JP10 are used to perform voltage and current measurements.

**Figure 3-7. Backup Battery Schematic**

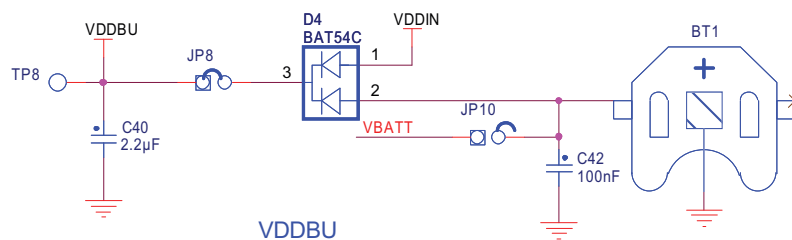

## 3.4 Embedded Memories

- I2C for data storage in EEPROM (Atmel AT24C1024B)
- SPI Serial Flash AT45 or AT25F

### 3.4.1 TWI EEPROM

The AT24C1024B provides 1,048,576 bits of serial electrically erasable and programmable read-only memory (EEPROM) organized as 131,072 words of 8 bits each.

Device slave address byte: 0x50.

**Figure 3-8. TWI EEPROM Schematic**

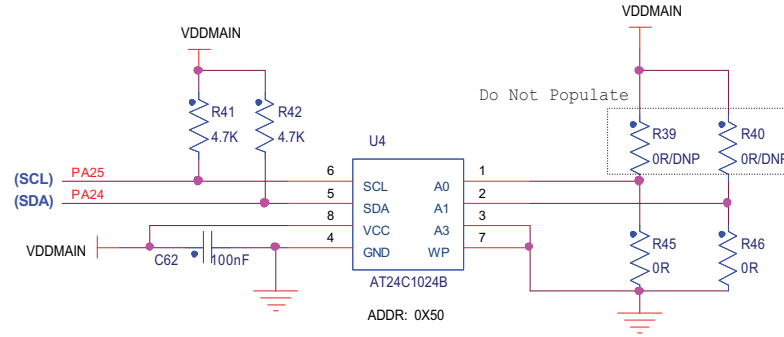

### 3.4.2 SPI Serial Flash

The SAM4C32-EK embeds one serial Flash device AT25DFxx or AT45DBxx connected through the SPI. (The AT25DF321A is mounted by default.)

**Figure 3-9. SPI Serial Flash Schematic**

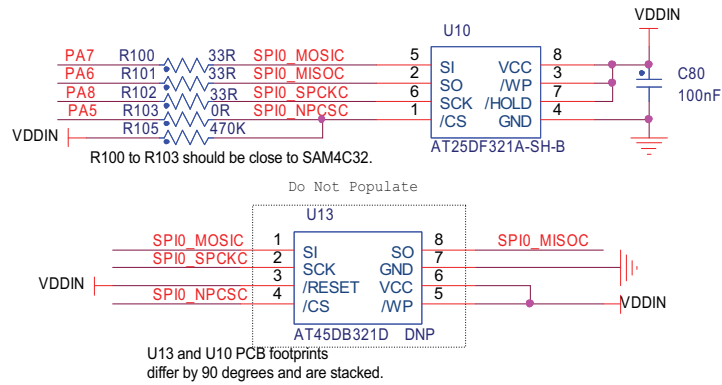

### 3.4.3 Adesto® Compatible Devices

**Table 3-3. Compatible Devices**

Adesto® AT45DB Series Devices	Adesto AT25DF Series Devices
AT45DB64D2-CNU	AT25DF641A-SH
AT45DB321D-MWU	AT25DF321A-SH
AT45DB131D-SS	AT25DF161-SH
AT45DB081D-SS	AT25DF081-SSH
AT45DB041D-SS	AT25DF021-SH
AT45DB021D-SS	—
AT45DB011D-SS	—



### 3.5.3 Serial Port UART1 RS232

The UART1 is buffered with an Analog Devices ADM3312E RS-232 transceiver and is connected to the HE10 PIO port C. A classic implementation RS232 transceiver selection should include double source capability.

Features:

- One RS232 transceiver connected to RXD (PC1) and TXD (PC0) only
- One HE10 male connector (PIO port C)
- Required resistors and capacitors

Figure 3-12. Serial Port Schematic

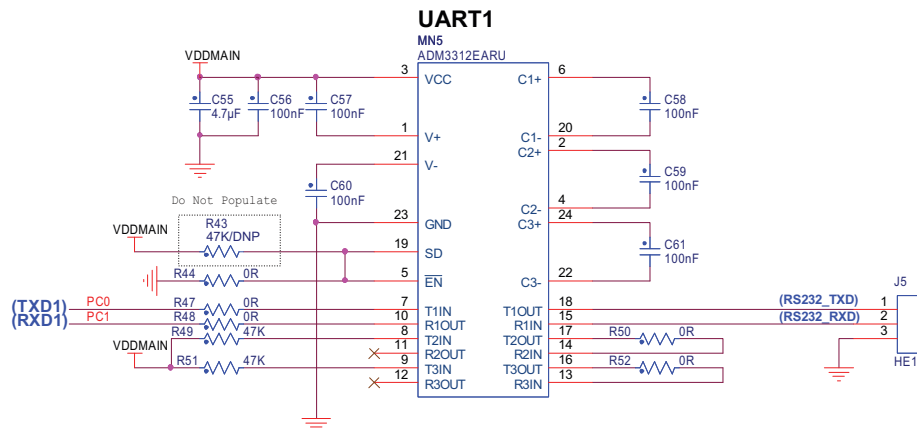

## 3.6 Debug Interfaces

### 3.6.1 JTAG/ICE

The SAM4C32-EK includes a JTAG interface port to provide debug level access to the system-on-chip. The JTAG port is a 20-pin, dual-row, 0.1-inch male connector. This port provides the required interface for in-circuit emulators such as the ARM Multi-ICE® and Atmel SAM-ICE™.

Features:

- One HE10 20-pin male connector
- Required resistors

**Figure 3-13. JTAG/ICE Interface Schematic**

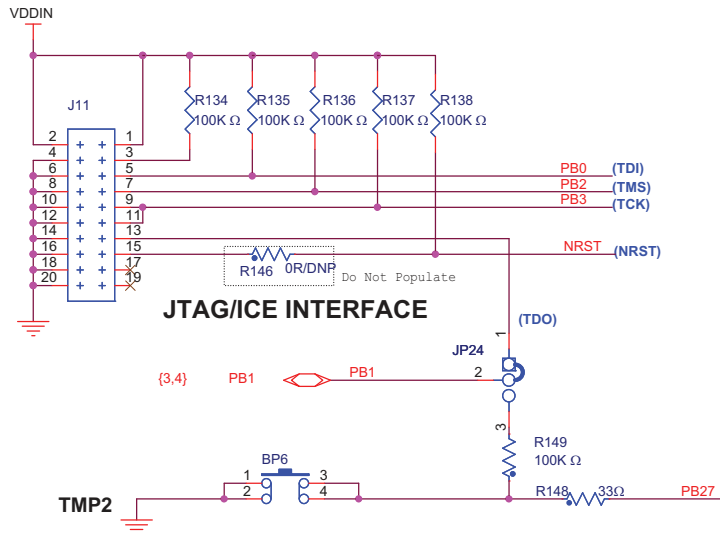

### 3.6.2 UART/USB Bridge Interface

The UART is connected to an interface USB through an FTDI FT232R (TTL to USB converter) device. RX and TX DBGU only are connected to the Micro AB USB connector.

**Figure 3-14. DBGU/USB Bridge Schematic**

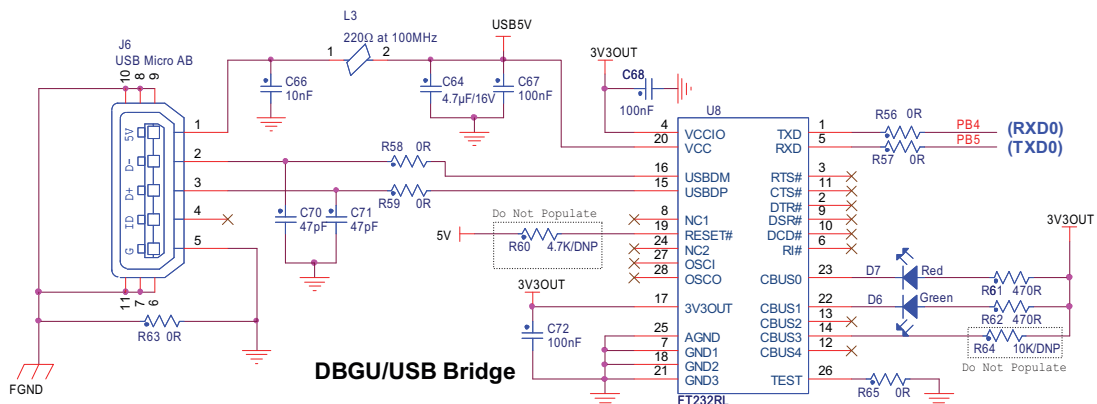

### 3.7 Extend Interfaces

The SAM4C32-EK embeds two connectors to interface Atmel IEEE 802.15.4-compliant wireless transceivers for ZigBee®-based applications.

Features:

- Atmel RZ600 module
- Atmel REB233-XPRO module

#### 3.7.1 RZ600 Interface

- The RZ600 interface connects with Atmel modules used for ZigBee communication platforms that are equipped with a 10-pin HE10 male connector.

Figure 3-15. RZ600 Interface Schematic

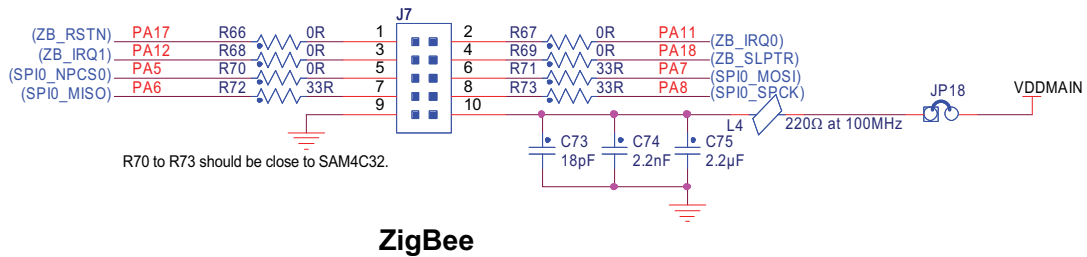

Table 3-4. RZ600 Pin Functions

Function	Pin	Pin	Function
Reset	1	2	IRQ0
Interrupt Request	3	4	SLP_TR
SPI Chip Select	5	6	SPI MOSI
SPI MISO	7	8	SPI CLK
Power Ground	9	10	Power Supply

#### 3.7.2 REB233-XPRO Interface

The XPRO interface connects with new Atmel modules used for XPRO platforms that are equipped with a 20-pin HE14 male connector.

Figure 3-16. XPRO Interface Schematic

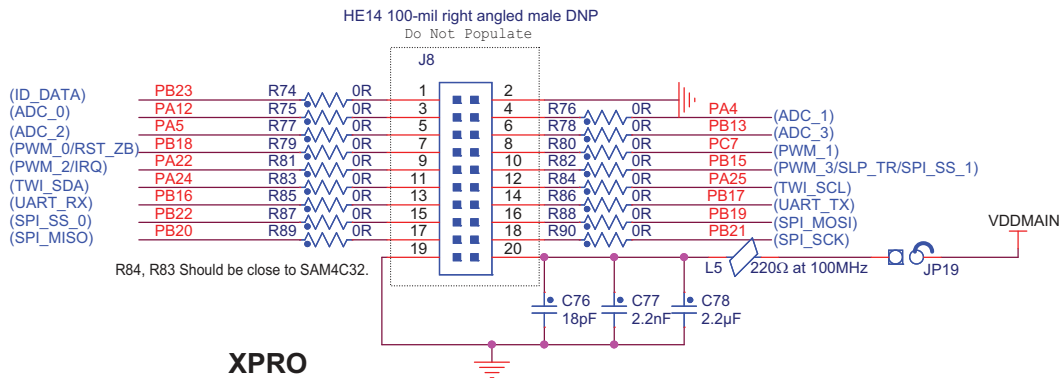





Figure 3-18. LCD Layout

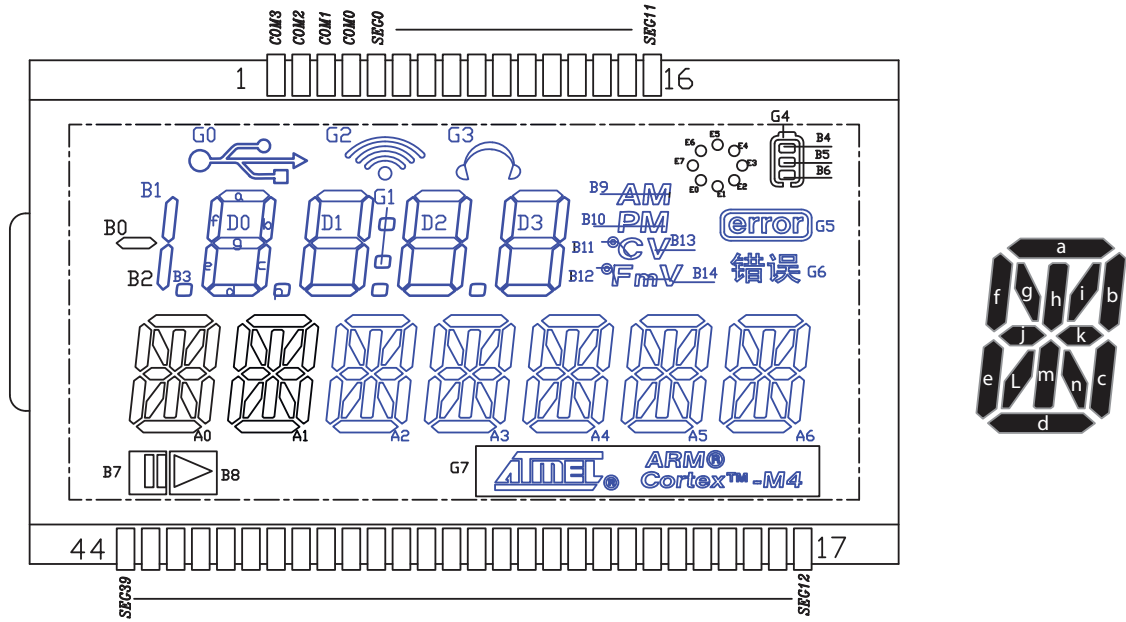

Table 3-6. LCD pinout vs Segment

Pin	COM0	COM1	COM2	COM3
1	-	-	-	COM3
2	-	-	COM2	-
3	-	COM1	-	-
4	COM0	-	-	-
5	G1	G0	G2	G3
6	G4	G5	G6	G7
7	E0	E2	E4	E6
8	E1	E3	E5	E7
9	D3-a	D3-b	D3-c	B9
10	D3-f	D3-g	D3-e	D3-d
11	D2-a	D2-b	D2-c	D2-p
12	D2-f	D2-g	D2-e	D2-d
13	D1-a	D1-b	D1-c	D1-p
14	D1-f	D1-g	D1-e	D1-d
15	D0-a	D0-b	D0-c	D0-p
16	D0-f	D0-g	D0-e	D0-d
17	A6-h	A6-i	A6-k	A6-n
18	B14	A6-f	A6-e	A6-d
19	A6-a	A6-b	A6-c	B13

Pin	COM0	COM1	COM2	COM3
23	A5-a	A5-b	A5-c	B12
24	A5-g	A5-j	A5-L	A5-m
25	A4-h	A4-i	A4-k	A4-n
26	B6	A4-f	A5-e	A5-d
27	A4-a	A4-b	A4-c	B11
28	A4-g	A4-j	A4-L	A4-m
29	A3-h	A3-i	A3-k	A3-n
30	B4	A3-f	A3-e	A3-d
31	A3-a	A3-b	A3-c	B10
32	A3-g	A3-j	A3-L	A3-m
33	A2-h	A2-i	A2-k	A2-n
34	B3	A2-f	A2-e	A2-d
35	A2-a	A2-b	A2-c	B1
36	A2-g	A2-j	A2-L	A2-m
37	A1-h	A1-i	A1-k	A1-n
38	B2	A1-f	A1-e	A1-d
39	A1-a	A1-b	A1-c	B8
40	A1-g	A1-j	A1-L	A1-m
41	A0-h	A0-i	A0-k	A0-n

**Table 3-6. LCD pinout vs Segment (Continued)**

Pin	COM0	COM1	COM2	COM3
20	A6-g	A6-j	A6-L	A6-m
21	A5-h	A5-i	A5-k	A5-n
22	B5	A5-f	A5-e	A5-d

Pin	COM0	COM1	COM2	COM3
42	B0	A0-f	A0-e	A0-d
43	A0-a	A0-b	A0-c	B7
44	A0-g	A0-j	A0-L	A0-m

**Table 3-7. LCD PIO Mapping**

Pin Name	LCD Pin	PIO	PIO	LCD Pin	Pin Name
COM0	4	PA0	PA1	3	COM1
COM2	2	PA2	PA3	1	COM3
SEG0	5	PB30	PB31	6	SEG1
SEG2	7	Not used	Not used	8	SEG3
SEG4	9	PB9	PB8	10	SEG5
SEG6	11	PB7	PB6	12	SEG7
SEG8	13	PA28	PA27	14	SEG9
SEG10	15	PA26	PA23	16	SEG11
SEG12	17	PB29	PB28	18	SEG13
SEG14	19	PB27	PB26	20	SEG15
SEG16	21	PB25	PB24	22	SEG17
SEG18	23	PB23	PB22	24	SEG19
SEG20	25	PB21	PB20	26	SEG21
SEG22	27	PB19	PB18	28	SEG23
SEG24	29	PB17	PB16	30	SEG25
SEG26	31	PB15	PB14	32	SEG27
SEG28	33	PB13	PB12	34	SEG29
SEG30	35	PB11	PB10	36	SEG31
SEG32	37	PB9	PB8	38	SEG33
SEG34	39	PB7	PB6	40	SEG35
SEG36	41	PA28	PA27	42	SEG37
SEG38	43	PA26	PA23	44	SEG39

## 3.9 Analog I/O

### 3.9.1 Analog Reference

The SAM4C32 features an LM4040 precision micropower curvature-corrected bandgap shunt voltage reference with several fixed reverse breakdown voltages. The device voltage reference on the board is 3.0V.

Figure 3-19. Analog Reference Schematic

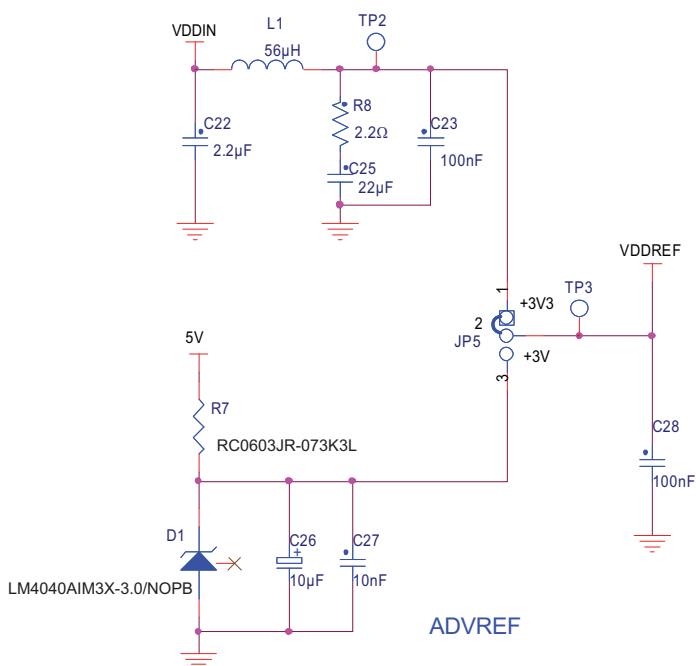

### 3.9.2 Analog Input

One VR1 multi-turn 10K  $\Omega$  potentiometer is connected to the jumper JP4. If JP4 is closed, this analog reference is available on analog input PA4.

Figure 3-20. Analog Input Schematic

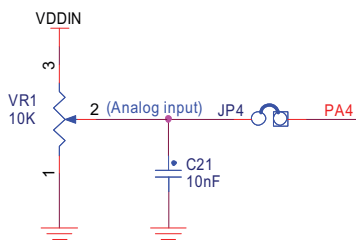

### 3.9.3 Temperature Sensor

The Atmel AT30TS75 temperature sensor converts temperatures from  $-40^{\circ}\text{C}$  to  $+125^{\circ}\text{C}$  to a digital word and provides a typical accuracy of  $\pm 0.5^{\circ}\text{C}$  over the operating temperature range of  $0^{\circ}\text{C}$  to  $+85^{\circ}\text{C}$ . The device is factory calibrated and requires no external components to help provide a cost effective solution. To reduce current consumption and save power, the AT30TS75 features a shutdown mode that turns off all internal circuitry except for the internal power-on reset and serial interface circuits. In addition, the device features a power saving one-shot mode that allows the device to make a temperature measurement, update the temperature register and then return to shutdown mode.

Device slave address byte: 0x48.

**Figure 3-21. Temperature Sensor Schematic**

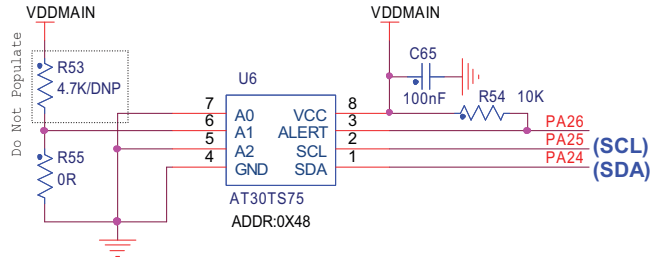

### 3.10 CryptoAuthentication (optional)

The Atmel ATSHA204 is a member of the Atmel CryptoAuthentication family of high-security hardware authentication devices.

It's flexible command set allows use in a number of applications, such as Anti-counterfeiting, Protection for Firmware or Media, Session Key Exchange, Secure Data Storage or User Password Checking.

Device slave address byte: 0xC9.

**Figure 3-22. CryptoAuthentication Schematic**

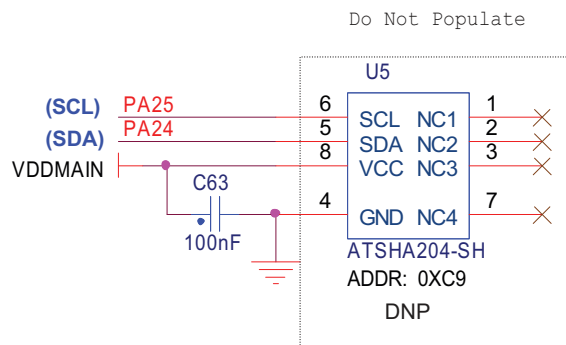

## 3.11 LEDs and Buttons

The SAM4C32-EK is equipped with two user push buttons and three LEDs.

### 3.11.1 Discrete LEDs

Indicators on the main board include three discrete LEDs:

- Blue LED connected to a PIO
- Amber LED connected to a PWM output
- Green LED connected to a PWM output

Figure 3-23. Debug Discrete LED Schematic

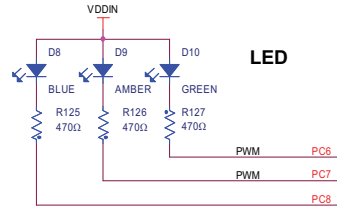

### 3.11.2 Push Buttons

The EK board is equipped with four system push buttons and two user push buttons. The push buttons consist of momentary push-button switches mounted directly to the board. A depressed switch causes a low (zero) to appear at the associated input pin.

- System push buttons:
  - NRST (Reset, perform system reset)
  - FWPU (Force Wake-Up)
  - TMP0 (Tamper)
  - TMP2 (Tamper)
- User push buttons:
  - SCROLL\_UP
  - SCROLL\_DOWN

Figure 3-24. Push Buttons Schematic

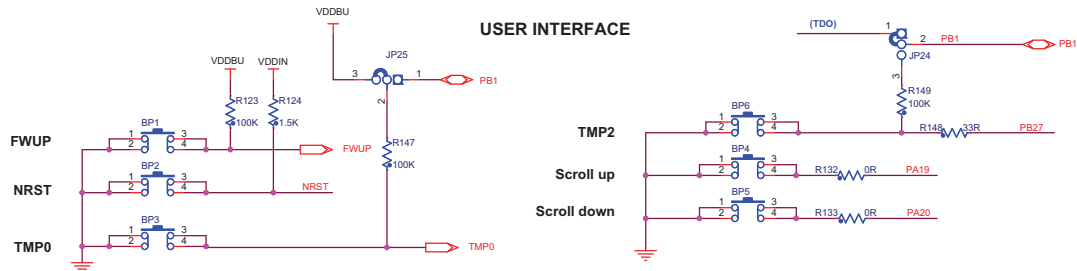

The user can select the pull-up level for the Tamper TMP0 pin by changing the position of JP25. Selecting PB1 instead of VDDBU provides dynamic tampering synchronized with RTCOUT (PB1) pin. This position allows a diminution of the power consumption when the button is pressed (divided by the Duty Cycle applied on RTCOUT Output signal).

It is possible to use the TMP2 push button as an additional Tamper input. To use this feature, the user must use JTAG in 2-wire mode (SWIO and SWD) due to the loss of the TDO pin. In this case, TMP2 is pull-up at RTCOUT Level (PB1 pin) and can be managed dynamically synchronized with the RTCOUT pin.

### 3.12 Miscellaneous I/O

This board is equipped with additional I/O connectors which allow the measurements of specific points as well as the connection of an additional extension board.

Figure 3-25. PIO A and PIO B Extension I/O Connectors Schematic

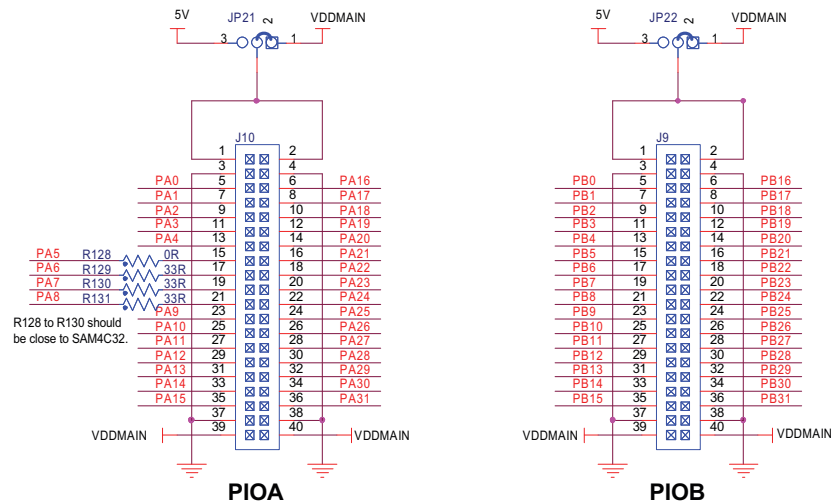

### 3.13 Metrology Core Serial Interface

This board includes an additional connector which allows connecting to an external board through the SPI 1 port.

Figure 3-26. Connector Schematic

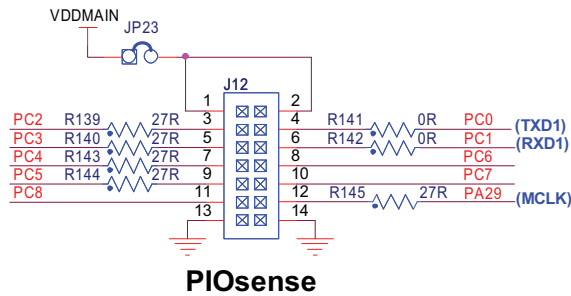

## 3.14 PIO Usage

### 3.14.1 PIO Port A Pin Assignments

Table 3-8. PIO Port A Pin Assignments

I/O Line	Peripheral			Extra Function	System Function	Reset State	Using	
	A	B	C					
PA0	RTS3	PCK2	A10	COM0	WKUP5	PIO, I, PU, ST	LCD Com	
PA1	CTS3	NCS1	A9	COM1	–		LCD Com	
PA2	SCK3	NCS2	A8	COM2	–		LCD Com	
PA3	RXD3	NCS3	A7	COM3	WKUP6		LCD Com	
PA4	TXD3	–	A6	COM4/AD1	–		Analog input	
PA5	SPI0_NPCS0	–	A5	COM5/AD2	–		SerFlash / NPCS	
PA6	SPI0_MISO	–	A4	SEG0	–		ZigBee	
PA7	SPI0_MOSI	–	A3	SEG1	–		ZigBee	
PA8	SPI0_SPCK	–	A2	SEG2	–		ZigBee	
PA9	RXD2	–	A1	SEG3	WKUP2		RS232/485	
PA10	TXD2	–	A0/NBS0	SEG4	–		RS232/485	
PA11	RXD1	–	A23	SEG5	WKUP9		ZigBee / IRQ0	
PA12	TXD1	–	A22-NCLE	SEG6/AD0	–		ZigBee/IRQ1/IRTC	
PA13	SCK2	TIOA0	A21-NALE	SEG7	–		Backlight On/off	
PA14	RTS2	TIOB0	A20	SEG8	WKUP3		RS232/485	
PA15	CTS2	TIOA4	A19	SEG9	–		RS232/485	
PA16	SCK1	TIOB4	A18	SEG10	–		MuxLCD	
PA17	RTS1	TCLK4	A17	SEG11	WKUP7		ZigBee / RST	
PA18	CTS1	TIOA5	A16	SEG12	–		ZigBee / SLPTR	
PA19	RTS0	TCLK5	A15	SEG13	WKUP4		PB ScrUp	
PA20	CTS0	TIOB5	A14	SEG14	–		PB ScrDwn	
PA21	SPI0_NPCS1	–	A13	SEG15	–		ZigBee / NPCS	
PA22	SPI0_NPCS2	–	A12	SEG16	–		ZigBit / IRQ	
PA23	SPI0_NPCS3	–	A11	SEG17	–		–	
PA24	TWD0	–	A10	SEG18	WKUP1		TWI / ZigBit	
PA25	TWCK0	–	A9	SEG19	–		TWI / ZigBit	
PA26	CTS4	–	A8	SEG20	–		–	
PA27	–	–	NCS0	SEG21	–		–	
PA28	–	–	NRD	SEG22	–		–	
PA29	PCK1	–	NWAIT	SEG23	–		–	MCLK (ATSense)
PA30	PCK1	–	A15	–	XOUT		XOUT	–
PA31	PCK0	–	A14	–	XIN	XIN	–	



### 3.14.2 PIO Port B Pin Assignments

Table 3-9. PIO Port B Pin Assignments

I/O Line	Peripheral			Extra Function	System Function	Reset State	Using	
	A	B	C					
PB0	TWD1	–	–	–	TDI	JTAG, I, ST	–	
PB1	TWCK1	–	–	RTCOUT0	TDO/TRACESWO		–	
PB2	–	–	–	–	TMS/SWDIO		–	
PB3	–	–	–	–	TCK/SWCLK		–	
PB4	URXD0	TCLK0	A17	–	WKUP8	PIO, I, PU, ST	DBGU	
PB5	UTXD0	–	A16	–	–		DBGU	
PB6	–	–	D0	SEG24	–		–	
PB7	TIOA1	–	D1	SEG25	–		–	
PB8	TIOB1	–	D2	SEG26	–		–	
PB9	TCLK1	–	D3	SEG27	–		–	
PB10	TIOA2	–	D4	SEG28	–		–	
PB11	TIOB2	–	D5	SEG29	–		–	
PB12	TCLK2	–	D6	SEG30	–		–	
PB13	PCK0	–	D7	SEG31/AD3	–		–	
PB14	–	–	NWR0–NWE	SEG32	–		–	
PB15	–	–	NWR1–NBS1	SEG33	–		ZigBit / SLPTR	
PB16	RXD0	–	D8	SEG34	WKUP10		PIO, I, PD, ST	ZigBit / RXD
PB17	TXD0	–	D9	SEG35	–			ZigBit / TXD
PB18	SCK0	PCK2	D10	SEG36	–			ZigBit / RST
PB19	RXD4	–	D11	SEG37	–	ZigBit / MOSI		
PB20	TXD4	–	D12	SEG38	–	ZigBit / MISO		
PB21	SCK4	NANDOE	D13	SEG39	WKUP11	ZigBit / SPCK		
PB22	RTS4	NANDWE	D14	SEG40	–	PIO, I, PD, ST	ZigBit / NPCS	
PB23	ADTRG	–	D15	SEG41/AD4	–		–	
PB24	TIOA3	–	A7	SEG42	–		–	
PB25	TIOB3	–	A6	SEG43	–		–	
PB26	TCLK3	–	A5	SEG44	WKUP13		–	
PB27	–	–	A4	SEG45	WKUP14		–	
PB28	–	–	A3	SEG46	WKUP15		–	
PB29	–	–	A2	SEG47	–		–	
PB30	–	–	A1	SEG48	–		–	
PB31	–	–	A0–NBS0	SEG49/AD5	–		–	

### 3.14.3 PIO Port C Pin Assignments

Table 3-10. PIO Port C Pin Assignments

I/O Line	Peripheral			Extra Function	System Function	Reset State	Using
	A	B	C				
PC0	UTXD1	PWM0	–	–	–	–	–
PC1	URXD1	PWM1	WKUP12	–	–	–	–
PC2	SPI1_NPCS0	PWM2	–	–	–	–	–
PC3	SPI1_MISO	PWM3	–	–	–	–	–
PC4	SPI1_MOSI	–	–	–	–	–	–
PC5	SPI1_SPCK	–	–	–	–	–	–
PC6	PWM0	SPI1_NPCS1	–	–	–	–	LED Green
PC7	PWM1	SPI1_NPCS2	–	–	–	–	LED Amber
PC8	PWM2	SPI1_NPCS3	–	–	–	–	LED Blue
PC9	PWM3	–	–	–	ERASE	–	Jumper Erase

## 3.15 Connectors

### 3.15.1 Power Supply Connector

The SAM4C32-EK is equipped with an ACDC wall adapter that can be connected to a J2 connector (described below). The maximum input voltage that can be applied on this connector must be lower than 6V.

Figure 3-27. Power Supply Connector



Table 3-11. Power Supply Connector Pinout

Pin	Signal Name	Description
1	+5V	Wall Adapter Main Voltage
2	NC	Floating Point
3	GND	Ground

### 3.15.2 JTAG/ICE Connector

Figure 3-28. JTAG/ICE Connector

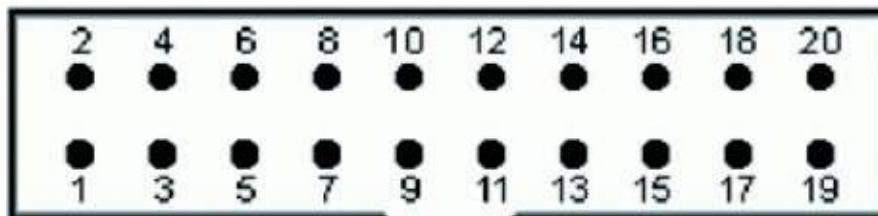

Table 3-12. JTAG/ICE Connector Pinout

Pin	Signal Name	Description
4, 6, 8, 10, 12, 14, 16, 18, 20	GND	Common ground
1	VTref 3.3V power	This is the target reference voltage. It is used to check if the target has power, to create the logic-level reference for the input comparators, and to control the output logic levels to the target. It is normally fed from VDD on the target board and must not have a series resistor.
2	Vsupply 3.3V power	This pin is not connected in SAM-ICE. It is reserved for compatibility with other equipment. Connect to VDD or leave open in target system.
3	nTRST TARGET RESET	JTAG Reset (active-low output signal that resets the target). Output from SAM-ICE to the Reset signal on the target JTAG port. Typically connected to nTRST on the target CPU. This pin is normally pulled HIGH on the target to avoid unintentional resets when there is no connection.
5	TDI TEST DATA INPUT	JTAG data input of target CPU (serial data output line, sampled on the rising edge of the TCK signal). It is recommended that this pin is pulled to a defined state on the target board. Typically connected to TDI on target CPU.
7	TMS TEST MODE SELECT	JTAG mode set input of target CPU. This pin should be pulled up on the target. Typically connected to TMS on target CPU. Output signal that sequences the target's JTAG state machine, sampled on the rising edge of the TCK signal.
9	TCK TEST CLOCK	JTAG clock signal to target CPU (output timing signal, for synchronizing test logic and control register access). It is recommended that this pin is pulled to a defined state on the target board. Typically connected to TCK on target CPU.
11	RTCK	Input Return test clock signal from the target. Some targets must synchronize the JTAG inputs to internal clocks. To assist in meeting this requirement, a returned and retimed TCK can be used to dynamically control the TCK rate. SAM-ICE supports adaptive clocking which waits for TCK changes to be echoed correctly before making further changes. Connect to RTCK if available, otherwise to GND
13	TDO JTAG TEST DATA OUTPUT	JTAG data output from target CPU (serial data input from the target). Typically connected to TDO on target CPU.
15	nSRST RESET	Active-low reset signal. Target CPU reset signal
17	RFU	This pin is not connected in SAM-ICE
19	RFU	This pin is not connected in SAM-ICE

### 3.15.3 RS232 Connector

Figure 3-29. RS232 Connector

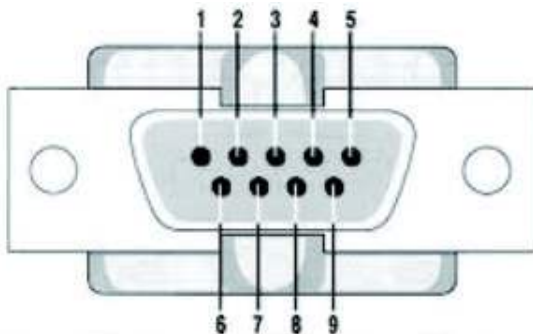

Table 3-13. RS232 Connector Pinout

Pin	Signal Name	Description
1, 4, 6, 9	NC	Not Connected
2	RXD	RS232 Serial Data Output Signal
3	TXD	RS232 Serial Data Input Signal
5	GND	Common Ground
7	RTS	Request To Send - Not Used
8	CTS	Clear To Send - Not Used

### 3.15.4 UART/USB Micro AB

Figure 3-30. Micro AB USB Connector

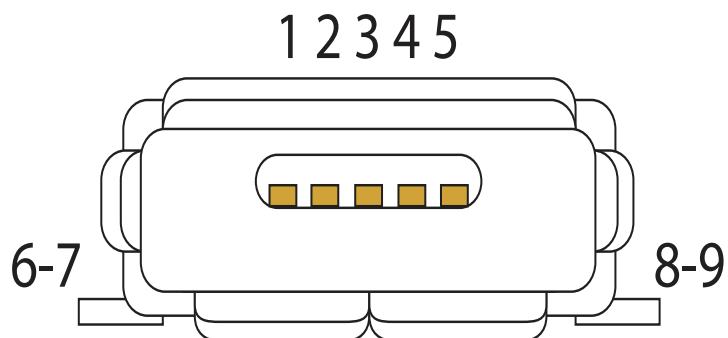

Table 3-14. Micro AB USB Connector Pinout

Pin	Signal Name	Description
1	VBUS	5V Power
2	DM	Data Minus
3	DP	Data Plus
4	ID	On The Go Identification
5	GND	Common Ground
6, 7, 8, 9	Shield	Mechanical Pins

### 3.15.5 RZ600 IEEE 802.15.4 Wireless Transceiver Socket J12

Figure 3-31. Socket J12

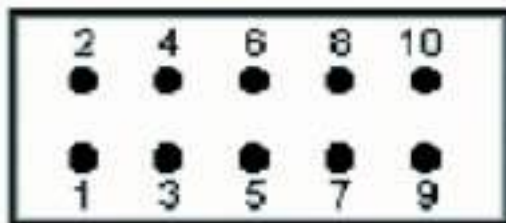

Table 3-15. Socket Pinout

Function	Signal Name	Pin		Pin	Signal Name	Function
Reset	/RST	1		2	IRQ0	Interrupt Request
Interrupt Request	IRQ1	3		4	SLP_TR	SLP_TR
SPI Chip Select	/CS	5		6	MOSI	SPI MOSI
SPI MISO	MISO	7		8	SCLK	SPI CLK
Power Supply	GND	9		10	VCC	VCC

### 3.15.6 I/O Expansion Port

Figure 3-32. Expansion Port J9 & J10

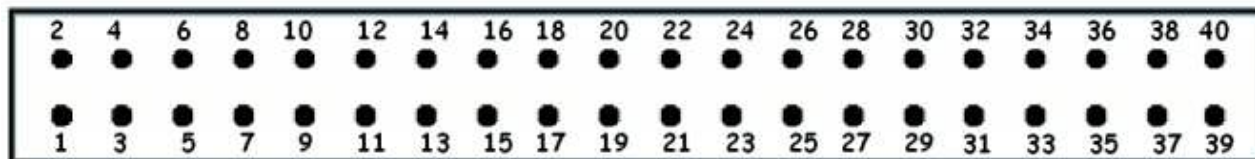

Table 3-16. Expansion Port J9 Pinout

Function	Signal Name	Pin	Pin	Signal Name	Function
3.3V or 5V	–	1	2	–	3.3V or 5V
Ground	GND	3	4	GND	Ground
–	PB0	5	6	PB16	–
–	PB1	7	8	PB17	–
–	PB2	9	10	PB18	–
–	PB3	11	12	PB19	–
–	PB4	13	14	PB20	–
–	PB5	15	16	PB21	–
–	PB6	17	18	PB22	–
–	PB7	19	20	PB23	–
–	PB8	21	22	PB24	–
–	PB9	23	24	PB25	–
–	PB10	25	26	PB26	–
–	PB11	27	28	PB27	–
–	PB12	29	30	PB28	–
–	PB13	31	32	PB29	–
–	PB14	33	34	PB30	–
–	PB15	35	36	PB31	–
Ground	GND	37	38	GND	Ground
Power Supply	VDDMAIN	39	40	VDDMAIN	Power Supply

Table 3-17. Expansion Port J10 Pinout

Function	Signal Name	Pin	Pin	Signal Name	Function
3.3V or 5V	–	1	2	–	3.3V or 5V
Ground	GND	3	4	GND	Ground
–	PA0	5	6	PA16	–
–	PA1	7	8	PA17	–
–	PA2	9	10	PA18	–

**Table 3-17. Expansion Port J10 Pinout (Continued)**

Function	Signal Name	Pin	Pin	Signal Name	Function
–	PA3	11	12	PA19	–
–	PA4	13	14	PA20	–
–	PA5	15	16	PA21	–
–	PA6	17	18	PA22	–
–	PA7	19	20	PA23	–
–	PA8	21	22	PA24	–
–	PA9	23	24	PA25	–
–	PA10	25	26	PA26	–
–	PA11	27	28	PA27	–
–	PA12	29	30	PA28	–
–	PA13	31	32	PA29	–
–	PA14	33	34	PA30	–
–	PA15	35	36	PA31	–
Ground	GND	37	38	GND	Ground
Power Supply	VDDMAIN	39	40	VDDMAIN	Power Supply

**Figure 3-33. Expansion Port J12**

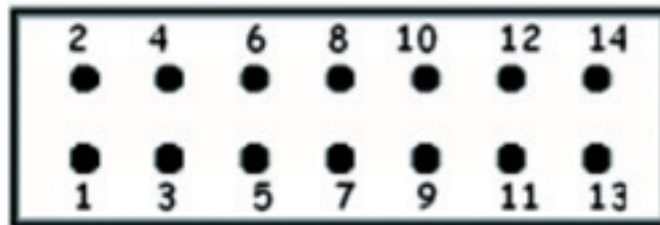

**Table 3-18. Expansion Port J12 Pinout**

PIO	Power	Pin	Pin	Power	PIO
–	3.3V	1	2	3.3V	–
PC2	–	3	4	–	PC0
PC3	–	5	6	–	PC1
PC4	–	7	8	–	PC6
PC5	–	9	10	–	PC7
PC8	–	11	12	–	PA29
–	GND	13	14	GND	–



## 4. SAM4C32-EK Firmware Demonstration

### 4.1 SAM4C32-EK Default Application

The SAM4C32-EK is delivered with a preprogrammed default application in SAM4C32 Flash memory. This application implements SAM4C32 embedded peripherals and external (on-board) peripherals as detailed in the table below.

**Table 4-1. SAM4C32 Embedded Peripherals**

Peripheral	Connected to External (on-board) Peripheral
Real-Time Clock (RTC)	—
Anti-Tamper	BP3 Push Button
Two-wire Interface	Temperature Sensor AT30TS75
Segmented LCD	Custom Atmel Display
SAM4C32 Core 1	—
10-bit ADC	Internal ADC channel connected to Battery Backup Power Rail (VDDBU)

After the first power-up without the backup battery, the time (hour and minute) of the RTC can be configured. The Hour and Minute settings are entered using the following push buttons:

- BP4 (SCROLL\_UP)—sets the Hour (24H mode entries must be made)
- BP5 (SCROLL\_DOWN)—sets the Minute
- BP6 (TMP2)—saves the Hour and Minute settings

Once the time settings have been saved, BP4 (SCROLL\_UP) can be used to toggle the Hour display between 12H or 24H mode.

Note: RTC time configuration can be skipped by pressing BP6.

Once the hour and minute have been configured, the main application on core 0 runs in an infinite loop, repeating the following steps:

- Every second, the time is displayed with colon (:) icon blinking
- Every fifteen (15) seconds, the VDDBU pin voltage is measured and displayed <sup>(1)</sup>
- Every thirty (30) seconds, the temperature (using the AT30TS75) is measured and displayed in °C and in °F.

Note: 1. On the SAM4C32-EK, the voltage measured is the VDDIO voltage minus the forward voltage of the diode in the BAT54C (D4).

At startup, the main application configures the core 1 subsystem to run a CoreMark algorithm from the core 1 SRAM memories (SRAM1 and SRAM2). Once the CoreMark is finished, the result of the CoreMark (number of CoreMark/MHz) is passed to the main application using the inter-processor communication embedded in the SAM4C32. Once the result is retrieved by the main application, the result of the CoreMark is displayed and the CoreMark algorithm running on core 1 is restarted. An ammeter connected either on JP12 (VDDIN) or on JP6 (VDDCORE) can measure the active current consumption of both cores.

## 4.2 Measuring the Backup Mode Current Consumption on VDDBU

The SAM4C32 has an ultra-low-power mode RTC and Supply controller allowing less than 1µA (typical) on VDDBU, with the following functions/peripherals configuration:

- 32.768 kHz Crystal Oscillator enabled
- POR backup on VDDBU disabled
- RTC running
- RTT enabled on 1 Hz mode
- Force wake-up (FWUP) enabled
- Anti-tamper Input (TMP0) enabled

To measure the current consumption on VDDBU when in backup mode, JP9 (Shutdown control) must be opened and an ammeter connected on JP8 (VDDBU) as described in the following procedure:

1. Power off the board using SW1
2. Insert the 3V lithium battery provided in the battery holder
3. Place an ammeter (with sufficient capacity to measure current lower than 1µA) on JP8
4. Power on the board using SW1
5. (*optional*) Set the RTC as described above
6. Press the push button BP5 (SCROLL\_DOWN) to place the board in low-power mode

Before shutdown, the following messages are displayed on the LCD:

“ENTERING BACKUP MODE”

“PRESS FWUP BP1 TO WAKE UP”

“USE BP3 TO GENERATE TAMPER EVENTS”

Blinking “BYE”

At this point, the current consumption on the ammeter should be less than 1µA @ 25°C @ 3V.

Once in backup mode, the anti-tamper pin 0 (TMP0) is enabled. The BP3 (TMP0) push button can be used to generate tamper events before waking up the board. Tamper events are registered without waking up the board. Up to 15 tamper events can be registered. To wake up the board, press BP1 (FWUP). Upon start-up, the number of tamper events and time-stamping of the tamper events are displayed on the LCD.

## 5. SAM4C32-EK Design Files

### 5.1 SAM4C32-EK Schematics

This section contains the schematics for the SAM4C32-EK (Rev. A).

- Main page with Block Diagram
- Information regarding the design
- SAM4C32 Microcontroller and its crystals, decoupling capacitors and analog inputs
- Power Supplies Distribution
- RS232, RS485 and DBGU Interfaces, TWI Memories, and Temperature Sensor
- Custom Glass LCD and ZigBee, XPRO interfaces
- User Buttons, I/O expansion headers and JTAG Interfaces



Figure 5-2. SAM4C32-EK Schematic (Page 2 of 7)

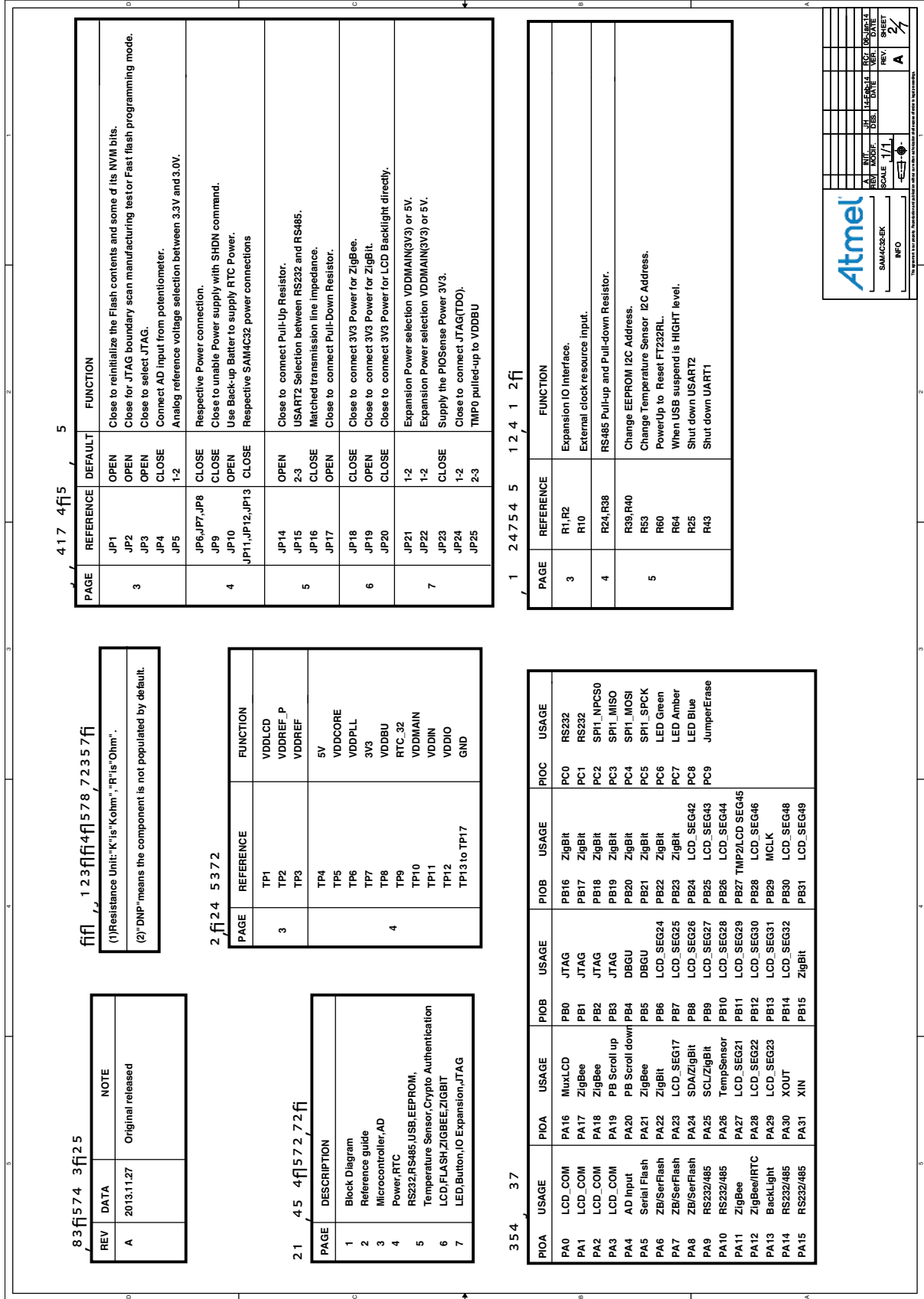



Figure 5-4. SAM4C32-EK Schematic (Page 4 of 7)

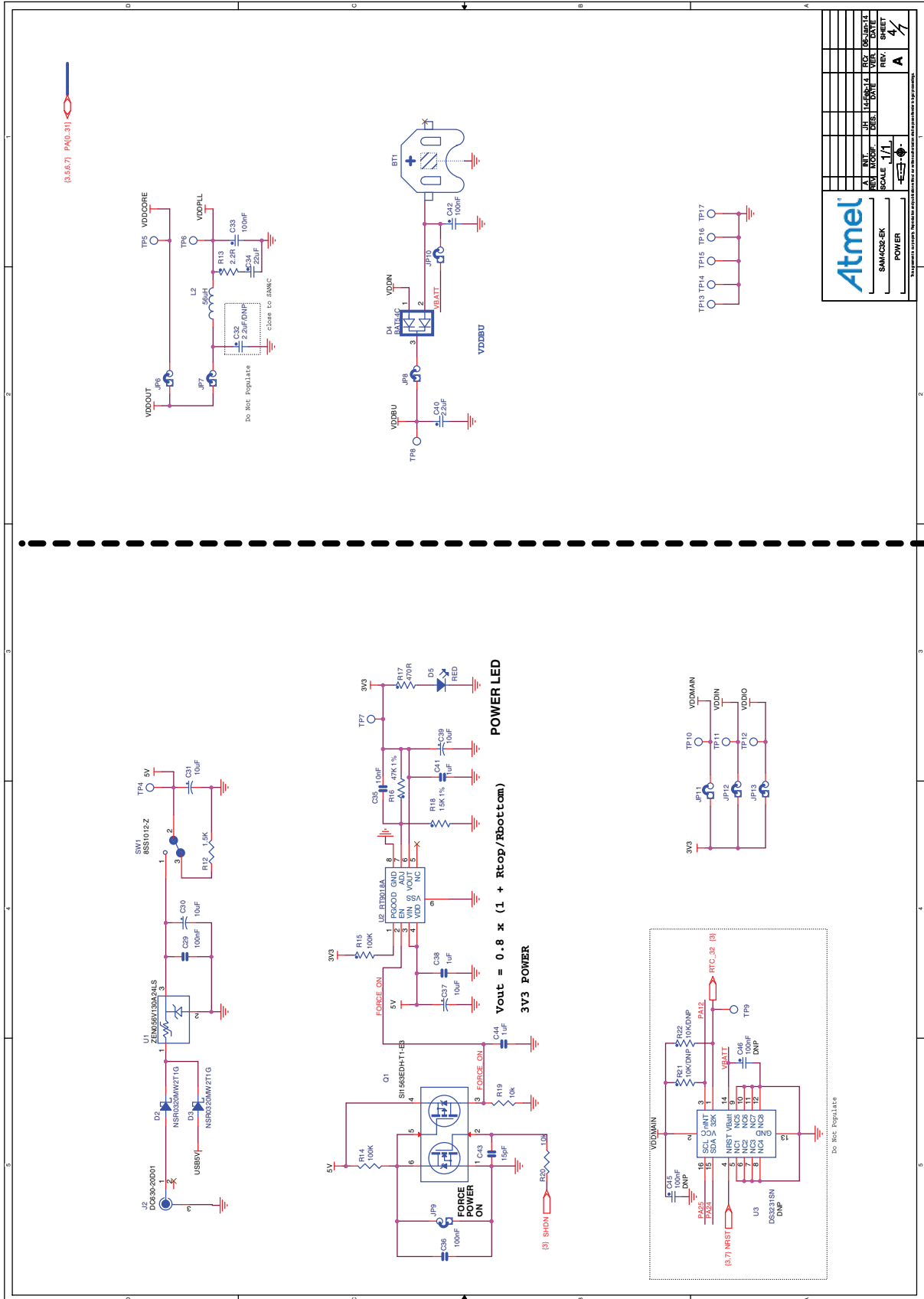



Figure 5-6. SAM4C32-EK Schematic (Page 6 of 7)

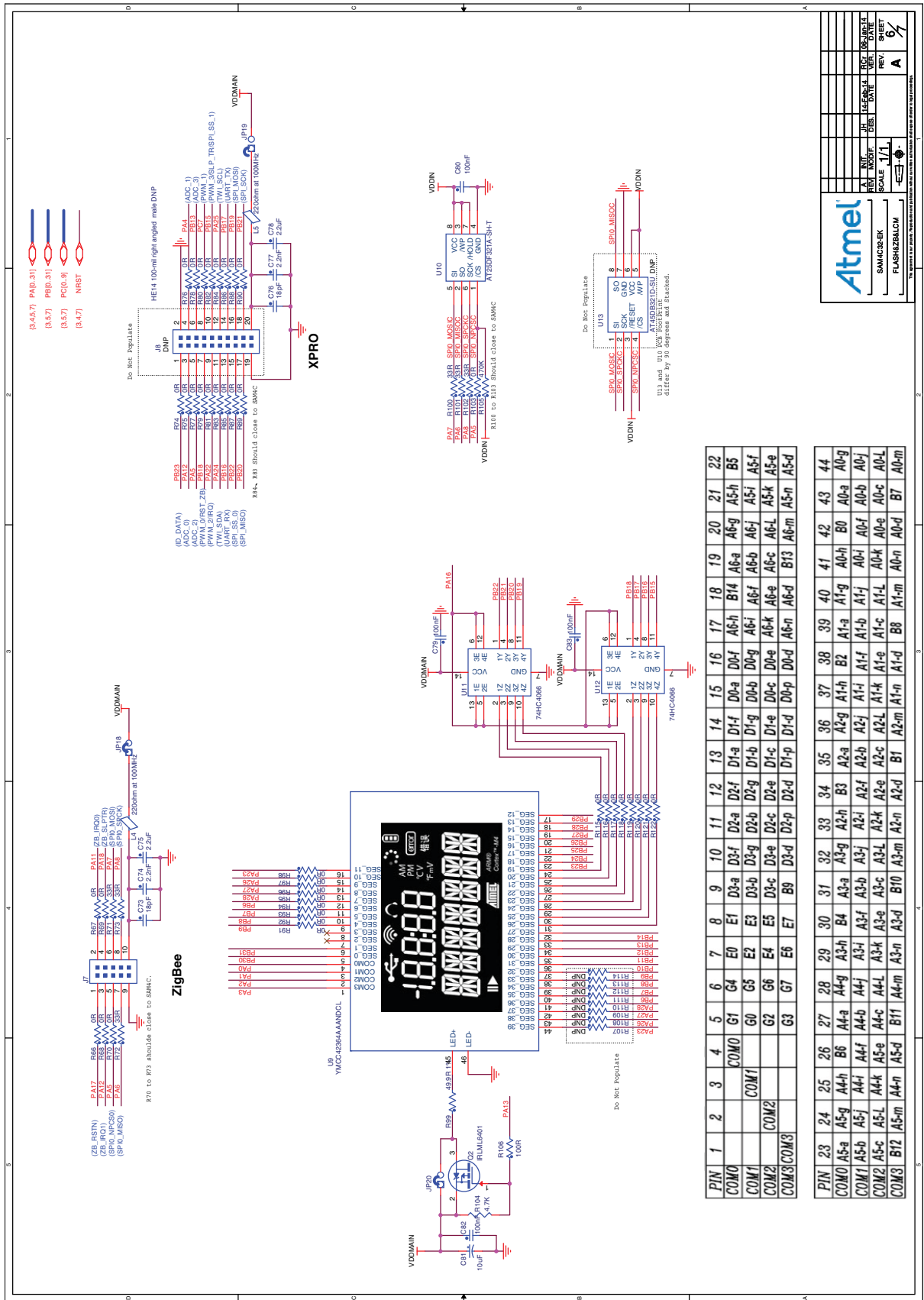
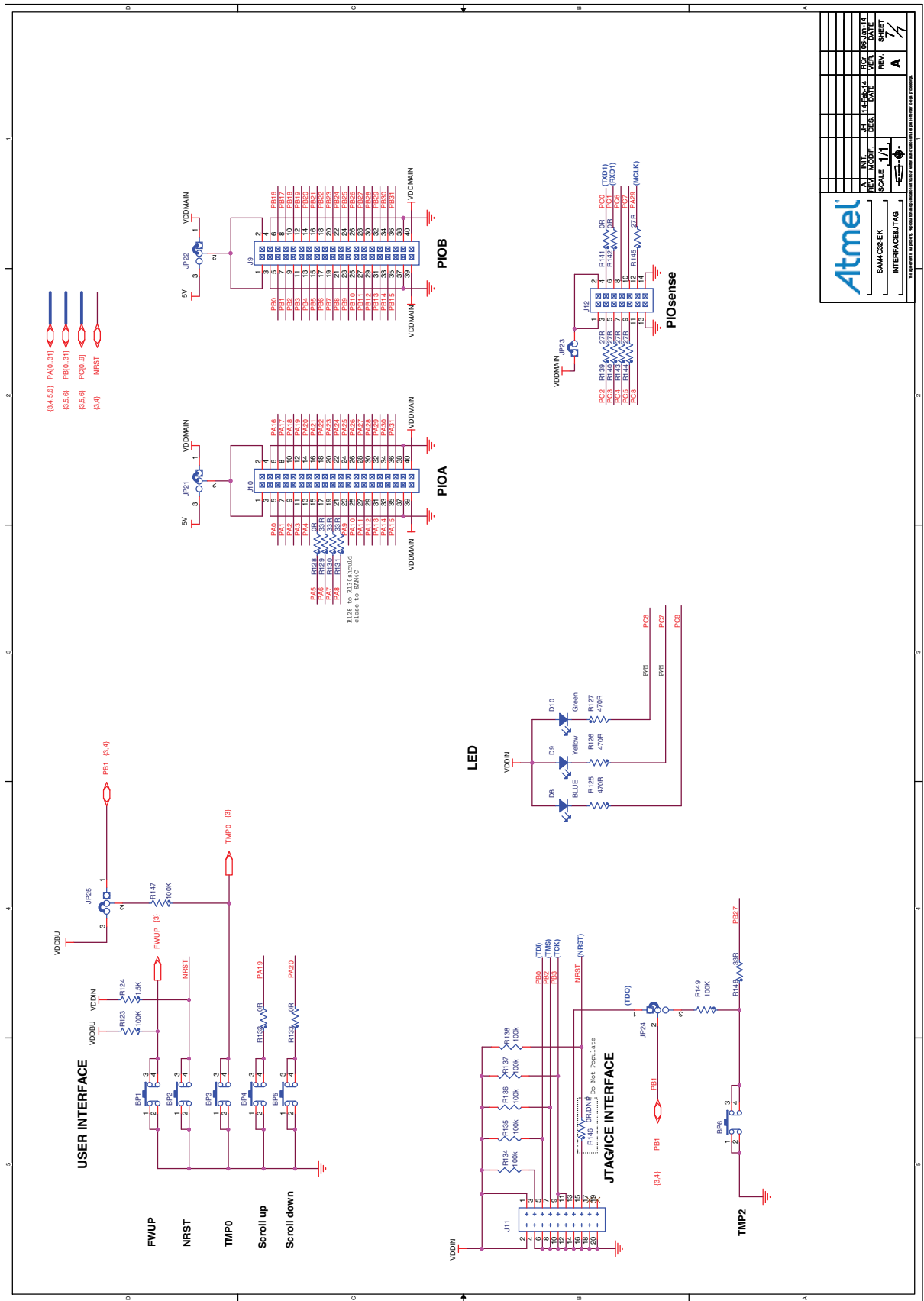



Figure 5-7. SAM4C32-EK Schematic (Page 7 of 7)



Atmel		SCALE 1/1		REV. A	
SAMS4C32-EK		INTERFACE/JTAG		REV. SHEET 7	
REV.	DATE	DESIGNER	DATE	SCALE	REV. SHEET
1.0	11/11/11	1.0	11/11/11	1/1	7





Figure 5-9. SAM4C32-EK Layout: Ground Layer

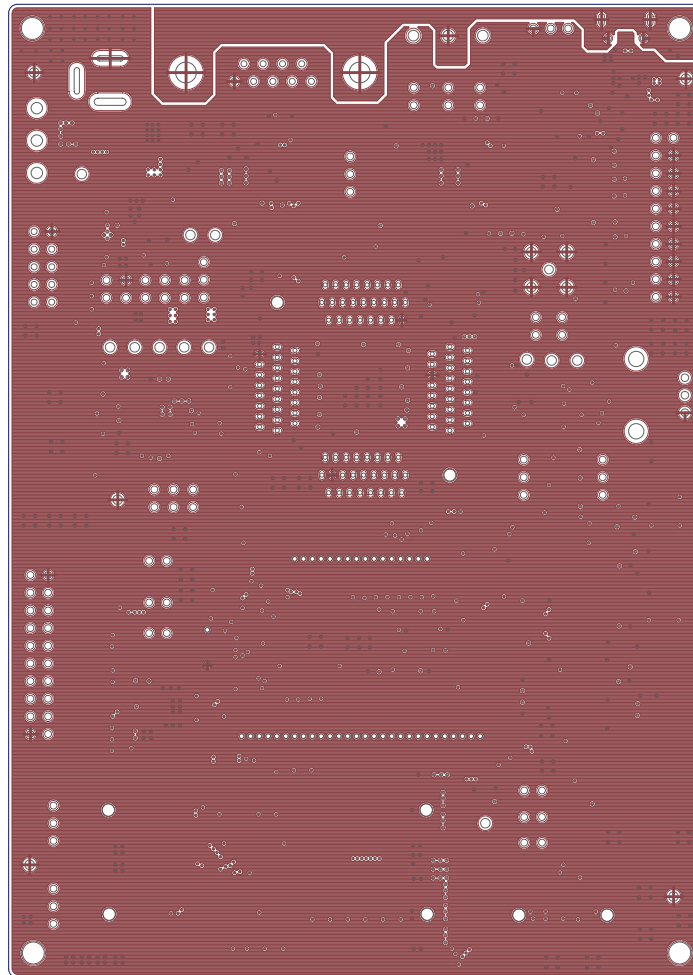

Figure 5-10. SAM4C32-EK Layout: Internal Signals 1 Layer

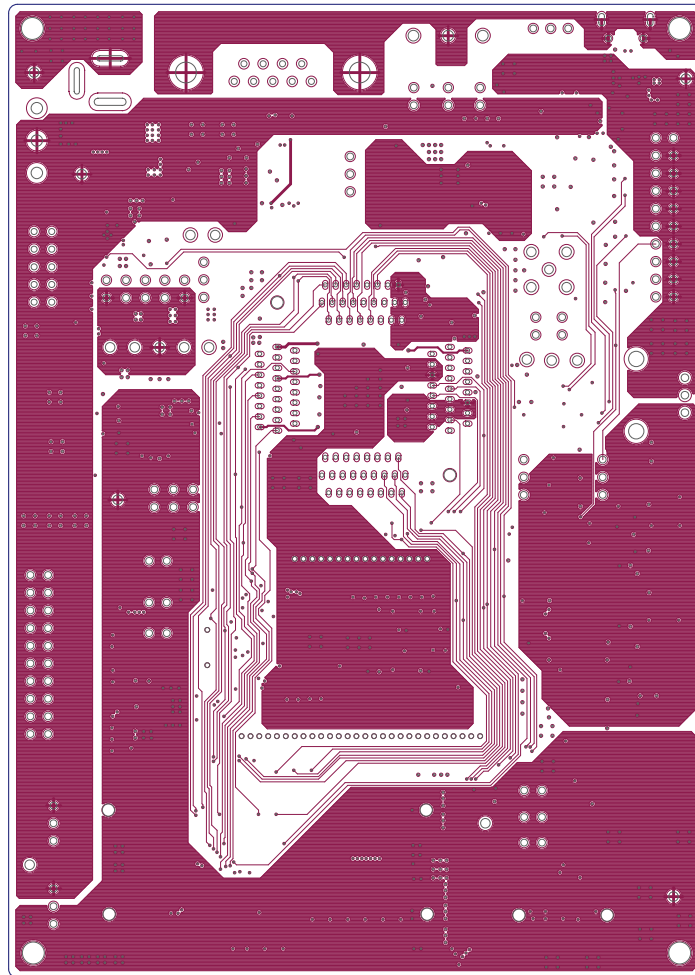

Figure 5-11. SAM4C32-EK Layout: Internal Signals 2 Layer

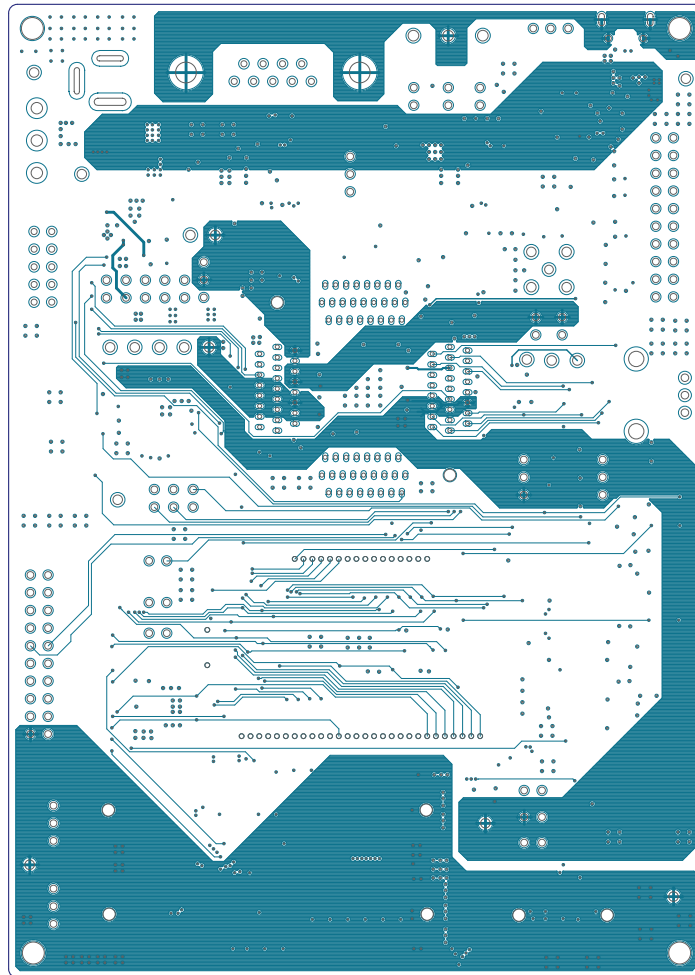

Figure 5-12. SAM4C32-EK Layout: Power Supplies Layer

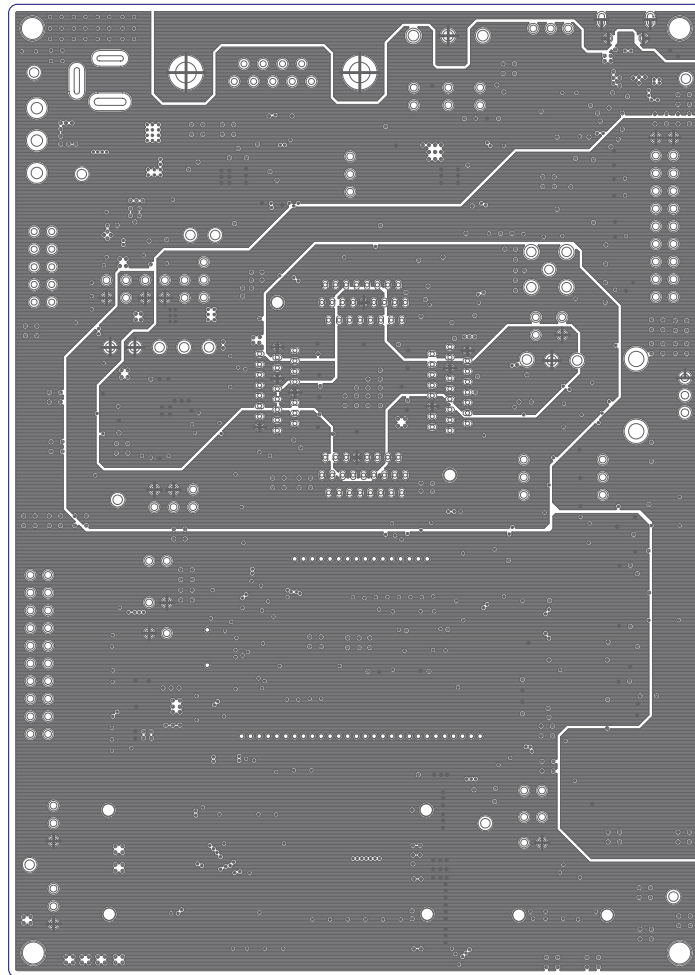

Figure 5-13. SAM4C32-EK Layout: Bottom Layer

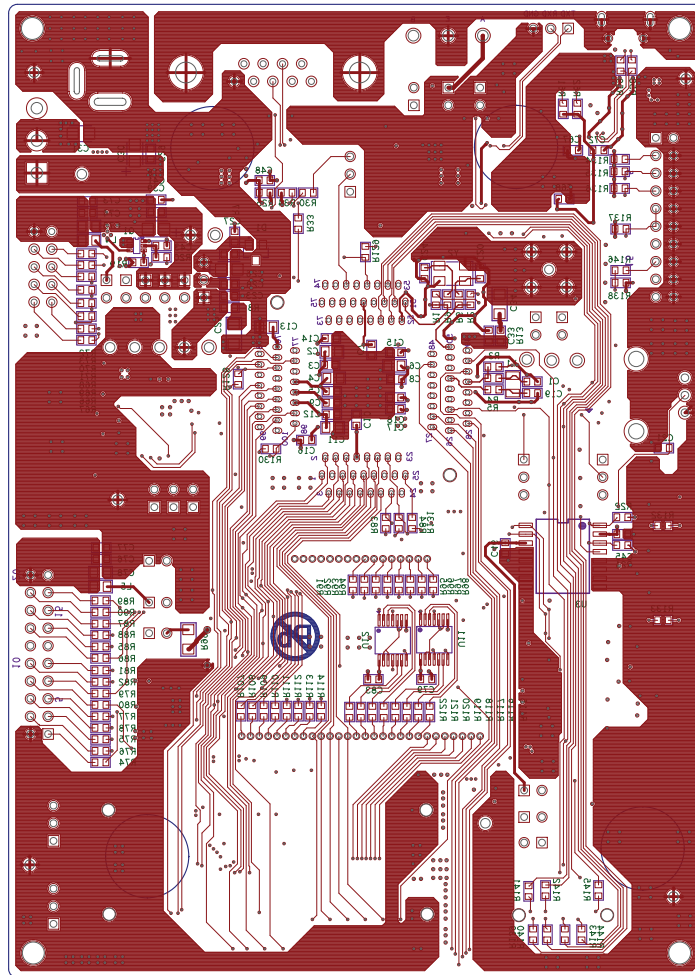
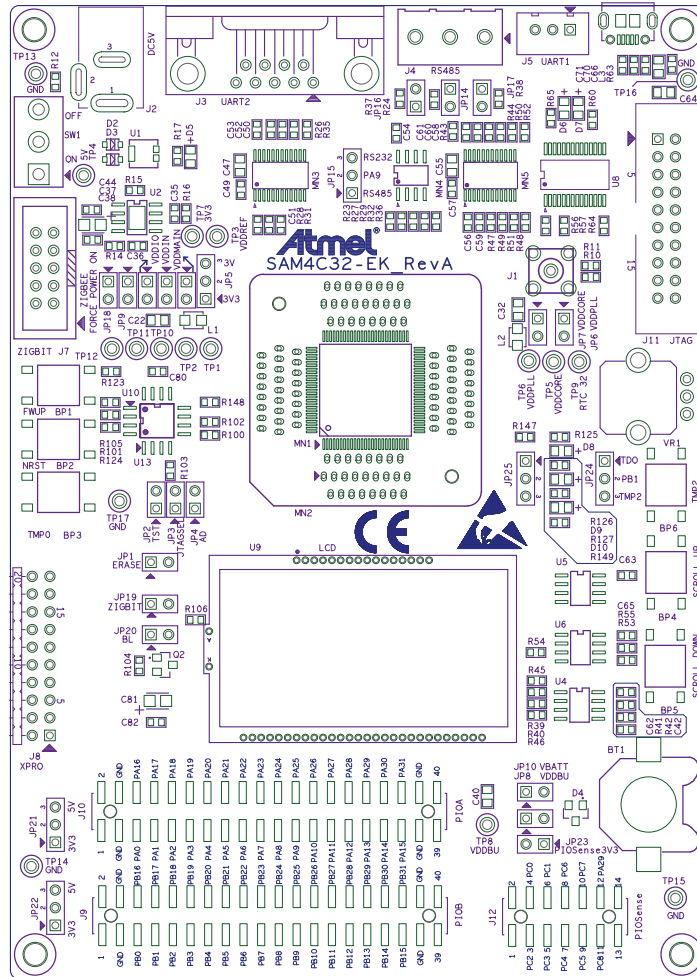

Figure 5-14. SAM4C32-EK Layout: TOP Components Placement







## 6. Revision History

Table 6-1. Revision History

Doc. Rev.	Date	Changes
A	17-Sep-2014	First issue



Atmel | Enabling Unlimited Possibilities®



Atmel Corporation 1600 Technology Drive, San Jose, CA 95110 USA T: (+1)(408) 441.0311 F: (+1)(408) 436.4200 | [www.atmel.com](http://www.atmel.com)

© 2014 Atmel Corporation. / Rev.: Atmel-11253A-ATARM-SAM4C32-EK-UserGuide\_17-Sep-14.

Atmel®, Atmel logo and combinations thereof, Enabling Unlimited Possibilities®, and others are registered trademarks or trademarks of Atmel Corporation in U.S. and other countries. ARM®, ARM Connected® logo, and others are the registered trademarks or trademarks of ARM Ltd. Other terms and product names may be trademarks of others.

DISCLAIMER: The information in this document is provided in connection with Atmel products. No license, express or implied, by estoppel or otherwise, to any intellectual property right is granted by this document or in connection with the sale of Atmel products. EXCEPT AS SET FORTH IN THE ATMEL TERMS AND CONDITIONS OF SALES LOCATED ON THE ATMEL WEBSITE, ATMEL ASSUMES NO LIABILITY WHATSOEVER AND DISCLAIMS ANY EXPRESS, IMPLIED OR STATUTORY WARRANTY RELATING TO ITS PRODUCTS INCLUDING, BUT NOT LIMITED TO, THE IMPLIED WARRANTY OF MERCHANTABILITY, FITNESS FOR A PARTICULAR PURPOSE, OR NON-INFRINGEMENT. IN NO EVENT SHALL ATMEL BE LIABLE FOR ANY DIRECT, INDIRECT, CONSEQUENTIAL, PUNITIVE, SPECIAL OR INCIDENTAL DAMAGES (INCLUDING, WITHOUT LIMITATION, DAMAGES FOR LOSS AND PROFITS, BUSINESS INTERRUPTION, OR LOSS OF INFORMATION) ARISING OUT OF THE USE OR INABILITY TO USE THIS DOCUMENT, EVEN IF ATMEL HAS BEEN ADVISED OF THE POSSIBILITY OF SUCH DAMAGES. Atmel makes no representations or warranties with respect to the accuracy or completeness of the contents of this document and reserves the right to make changes to specifications and products descriptions at any time without notice. Atmel does not make any commitment to update the information contained herein. Unless specifically provided otherwise, Atmel products are not suitable for, and shall not be used in, automotive applications. Atmel products are not intended, authorized, or warranted for use as components in applications intended to support or sustain life.

SAFETY-CRITICAL, MILITARY, AND AUTOMOTIVE APPLICATIONS DISCLAIMER: Atmel products are not designed for and will not be used in connection with any applications where the failure of such products would reasonably be expected to result in significant personal injury or death ("Safety-Critical Applications") without an Atmel officer's specific written consent. Safety-Critical Applications include, without limitation, life support devices and systems, equipment or systems for the operation of nuclear facilities and weapons systems. Atmel products are not designed nor intended for use in military or aerospace applications or environments unless specifically designated by Atmel as military-grade. Atmel products are not designed nor intended for use in automotive applications unless specifically designated by Atmel as automotive-grade.