

THIS DRAWING IS UNPUBLISHED. RELEASED FOR PUBLICATION .19
 (C) COPYRIGHT 19 BY AMP INCORPORATED. ALL RIGHTS RESERVED.

LOC		DIST		REVISIONS			
P	LTR	DESCRIPTION		DATE	DWN	APVD	
AF	50	E		REVISED PER EC 063A-0046-99	14JUL99	SW	KR

IDENTIFICATION NUMBER 5 FOR MAGNET WIRE RANGE

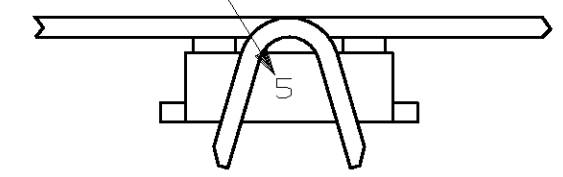

- 1 SLOT TERMINATES 0.23-0.32mm [#31-#28] AWG COPPER MAGNET WIRE EITHER SINGLE OR DOUBLE OF THE SAME SIZE.
- 2 CONTINUOUS STRIP ON REELS WITH TERMINALS LOCATED ON 8.38±0.08 [.330±.003] CENTERS.
- 3 WIRE BARREL TO ACCEPTS #22-#18 AWG STRANDED LEAD WIRE.

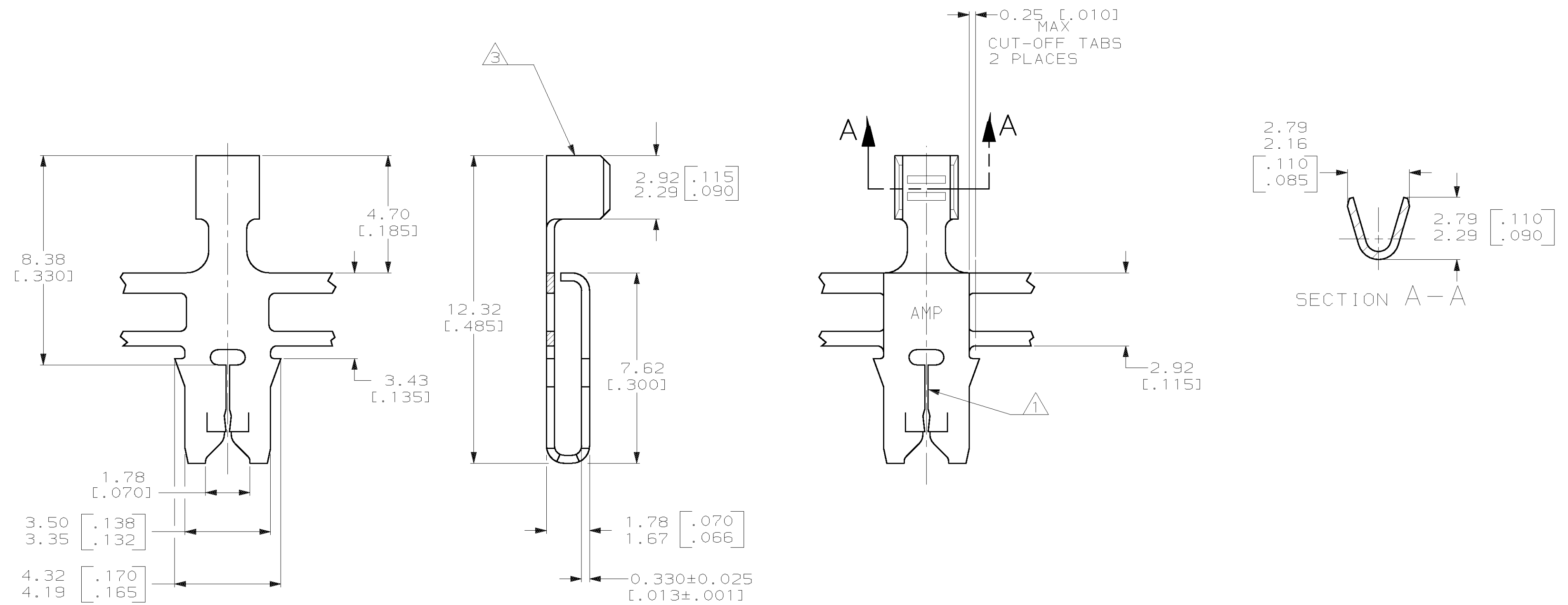

63236-1
PART NUMBER

THIS DRAWING IS A CONTROLLED DOCUMENT.		DWN MICHAEL S. FEHER 17SEP96	AMP Incorporated Harrisburg, PA 17105-3608	
DIMENSIONS: mm [INCHES]		CHK RICHARD GRZYBOWSKI 25SEP96	AMP	
TOLERANCES UNLESS OTHERWISE SPECIFIED:		APVD NELSON E. NEFF 25SEP96	TERMINAL, F-CRIMP, 300 SERIES, MAG-MATE™	
0 PLC ±-		PRODUCT SPEC 108-2012	SIZE A2	CAGE CODE 00779
1 PLC ±-		APPLICATION SPEC 114-2046	DRAWING NO C-63236	SCALE 8:1
2 PLC ±0.25 [.010]		MATERIAL 4M BRASS	WEIGHT -	SHEET 1 OF 1
3 PLC ±-		FINISH 0.002032 [.000080] MIN TIN	CUSTOMER DRAWING	REV E
4 PLC ±-				
ANGLES ±-				