

NOT RECOMMENDED FOR NEW DESIGN
USE [PAM8902H](#)

PAM8902A

**30-V_{PP} MONO CLASS-D AUDIO AMPLIFIER
for PIEZO/CERAMIC SPEAKERS with ANTI-SATURATION/CLIPPING**

Description

The PAM8902A is a mono, Class-D audio amplifier with integrated boost converter designed for piezo and ceramic speakers. The PAM8902A is capable for driving a ceramic/piezo speaker with 30V_{PP} (10.6V_{RMS}) from a 3.6V power supply. The boost converter operates at a fixed frequency of 1.5MHz and provides a 17.5V supply with a minimum number of external components.

The PAM8902A provide three fixed-gain settings of 18dB, 22dB, and 26dB. PAM's anti-saturation technology detects if the input has been over-driven and automatically decreases the gain to prevent the output signal from clipping. To improve fidelity, an integrated low-pass filter rejects any high-frequency noise. The PAM8902A also includes thermal, current limiting, under-voltage lockout, and over-voltage protection circuitry.

Package options include a 1.95mm x 1.95mm CSP and a 4mm x 4mm QFN.

Features

- Supply Voltage Range from 2.7V to 5.5V
- 30V_{PP} Boost Converter Output Voltage from a 3.6V Supply
- Selectable Boost Output Voltage of 8V, 12V, and 17.5V
- Integrated Boost Converter Generates 17.5V Supply
- Programmable Soft-Start
- Anti-Saturation Function Eliminates Clipping
- Selectable Gain of 18dB, 22dB, and 26dB
- Low Shutdown Current: < 1μA
- Build in Thermal, Over-Current Protection, Under-Voltage Lock-Out and Over Voltage Protection
- Available in Space Saving CSP and QFN4x4 Packages

Applications

- Wireless or Cellular Handsets
- Portable DVD Player
- Personal Digital Assistants (PDAs)
- Electronic Dictionaries
- Digital Still Cameras

Pin Assignments

16 Ball CSP
Top View

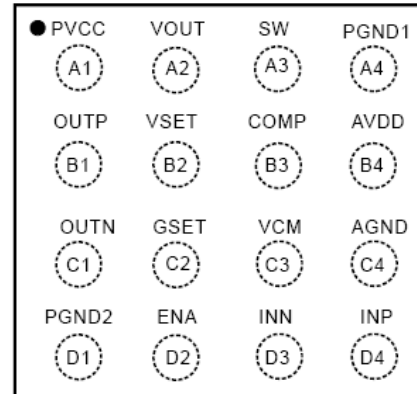

Top View
QFN 4X4 16L

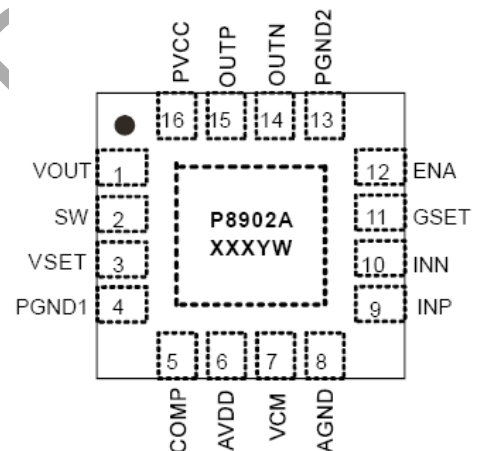

Typical Applications Circuit

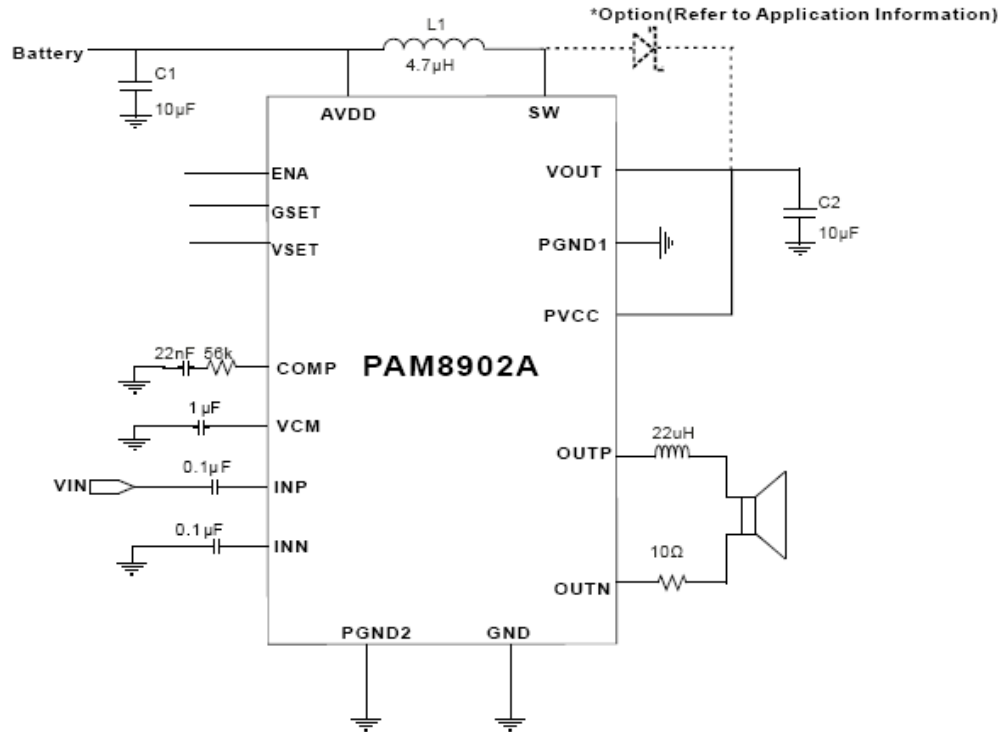

Pin Descriptions

Pin Name	Bump (CSP)	Pin Number QFN4x4	Function
PVCC	A1	16	Audio Amplifier Power Supply
VOUT	A2	1	Boost Converter Output
SW	A3	2	Boost Converter Switching Node
PGND1	A4	4	Boost Converter Power Ground
OUTP	B1	15	Positive Differential Audio Output
VSET	B2	3	Boost Converter Output Voltage Setting(8V,12V,17.5V)
COMP	B3	5	Boost Converter Compensation
AVDD	B4	6	Power Supply
OUTN	C1	14	Negative Differential Audio Output
GSET	C2	11	Amplifier Gain Setting (Refer to "Application Information")
VCM	C3	7	Common Mode Bypass Cap
AGND	C4	8	Analog Ground
PGND2	D1	13	Class D Power Ground
ENA	D2	12	Whole Chip Enable
INN	D3	10	Negative Differential Audio Input
INP	D4	9	Positive Differential Audio Input

Functional Block Diagram

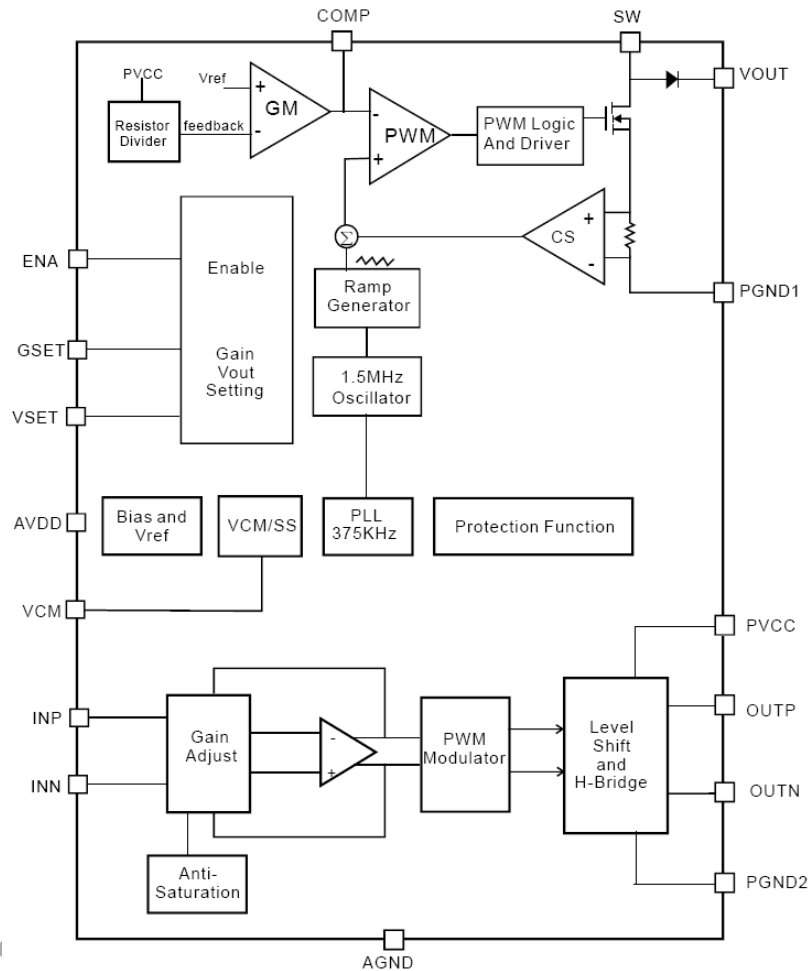

Absolute Maximum Ratings (@T_A = +25°C, unless otherwise specified.)

These are stress ratings only and functional operation is not implied. Exposure to absolute maximum ratings for prolonged time periods may affect device reliability. All voltages are with respect to ground.

Parameter	Rating	Unit
Supply Voltage	6.0	V
Input Voltage	-0.3 to V _{DD} +0.3	
Maximum Junction Temperature	+150	°C
Storage Temperature	-65 to +150	
Soldering Temperature	250, 10 sec	

Recommended Operating Conditions (@T_A = +25°C, unless otherwise specified.)

Parameter	Rating	Unit
Supply Voltage Range	2.5 to 5.5	V
Ambient Temperature Range	-40 to +85	°C
Junction Temperature Range	-40 to +125	°C

Thermal Information

Parameter	Package	Symbol	Max	Unit
Thermal Resistance (Junction to Ambient)	CSP	θ_{JA}	90 – 220	°C/W
	QFN4x4-16		37	
Thermal Resistance (Junction to Case)	CSP	θ_{JC}	75	
	QFN4x4-16		2	

Electrical Characteristics (@T_A = +25°C, V_{DD} = 3.6V, C_L = 1μF, V_{SET} floating, unless otherwise specified.)

Parameter	Symbol	Test Conditions	Min	Typ	Max	Units
Input Voltage	V _{DD}		2.7		5.5	V
Quiescent Current	I _Q	EN > 1.2V, V _{SET} = High		30	48	mA
		EN > 1.2V, V _{SET} = Floating		10	18	
		EN > 1.2V, V _{SET} = GND		5	12	
Shutdown Current	I _{SD}	EN = 0V		0.1	1	μA
Wake-Up Time	T _{WU}	EN from Low to High		40		mS
Chip Enable	V _{EH}		1.2			V
Chip Disable	V _{EL}				0.4	
GSET/ VSET High	V _H		V _{DD} -0.5		V _{DD}	V
GSET/ VSET Floating	V _F		1		V _{DD} -1	
GSET/ VSET Low	V _L		0		0.5	
Under Voltage Lockout Threshold	UVLO	V _{DD} from High to Low		2.2		V
Under Voltage Lockout Hysteresis	UVLO(H)	V _{DD} from Low to High		0.2		
Thermal Shutdown Threshold	OTP			150		°C
Thermal Shutdown Lockout Hysteresis	OTP(H)			30		°C
Boost Converter						
Output Voltage	V _{O1}	V _{SET} = Low, No Load	7.2	8.0	8.8	V
	V _{O2}	V _{SET} = Floating, No Load	10.8	12.0	13.2	V
	V _{O3}	V _{SET} = High, No Load	16.0	17.5	19.0	V
Current Limit	C _L	Average Input Current		0.8		A
Lowside MOSFET R _{DS(ON)}	R _{LS}	I _O = 50mA		0.5		Ω
Boost Switching Frequency	f _{OSCB}		1.1	1.5	1.9	MHz
Over Voltage Protection Threshold	V _{OVp}			18		V
Class D						
Class D Amplifier Switching Frequency	f _{OSCD}	Input AC-GND	225	375	475	KHz
Common Mode Reject Ratio	CMRR	V _{IN} = ±100mV, V _{DD} = 3.6V		60		dB
Output Offset Voltage	V _{OS}	Output Offset Voltage		5	50	mV
R _{DS(ON)}	R _P	High Side		1.5		Ω
		Low Side		0.6		Ω
Closed-Loop Voltage Gain	A _{V1}	G _{SET} = High, V _O = 1V _{RMS}	25	26	27	dB
	A _{V2}	G _{SET} = Floating, V _O = 1V _{RMS}	21	22	23	
	A _{V3}	G _{SET} = Low, V _O = 1V _{RMS}	17	18	19	
Power Supply Reject Ratio	PSRR	200m V _{PP} Supply Ripple @ 217Hz		70		dB
Total Harmonic Distortion Plus Noise	THD+N	V _O = 5V _{RMS}		0.3		%
Signal to Noise Ratio	SNR	Input AC Ground, A-Weighting		90		dB

Typical Performance Characteristics (@ $T_A = +25^\circ\text{C}$, $V_{DD} = 3.6\text{V}$, $C_L = 1\mu\text{F}$, $L = 4.7\mu\text{H}$, V_{SET} floating, $R_{LOAD} = 10\Omega$, $L_{LOAD} = 22\mu\text{H}$ with external schottky diode, unless otherwise specified.)

1. Supply Current VS Output Voltage ($V_o=8\text{V}$)

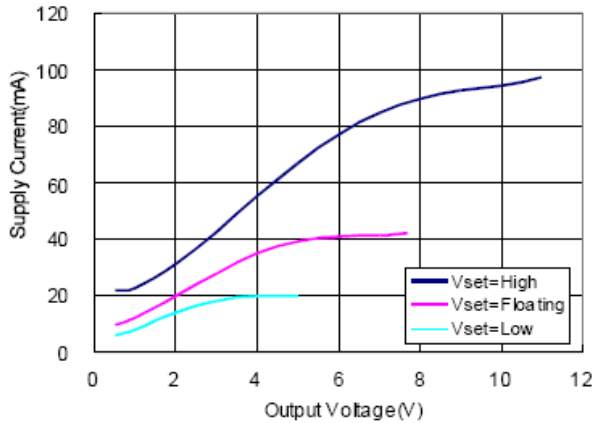

2. Input Power VS Output Voltage ($V_o=8\text{V}$)

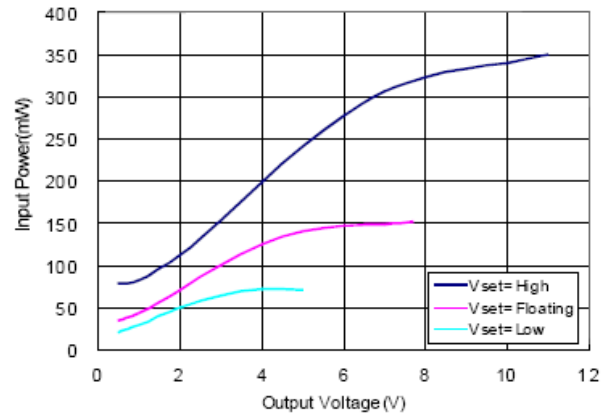

3. THD+N VS Frequency

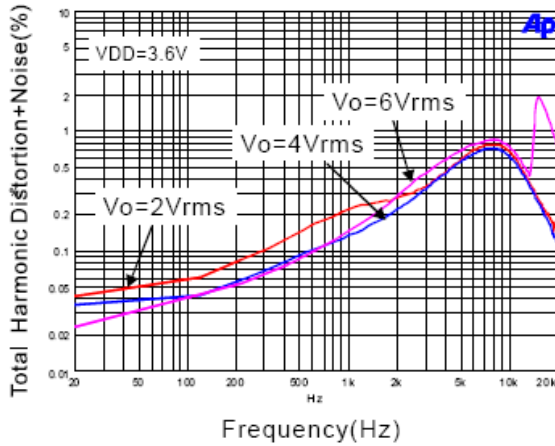

4. THD+N VS Frequency

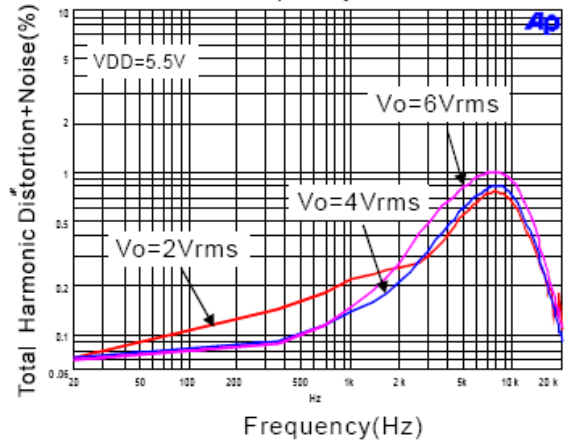

5. Gain VS Frequency

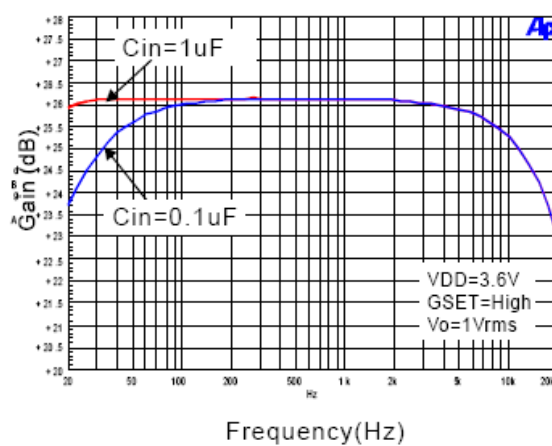

6. Gain VS Frequency

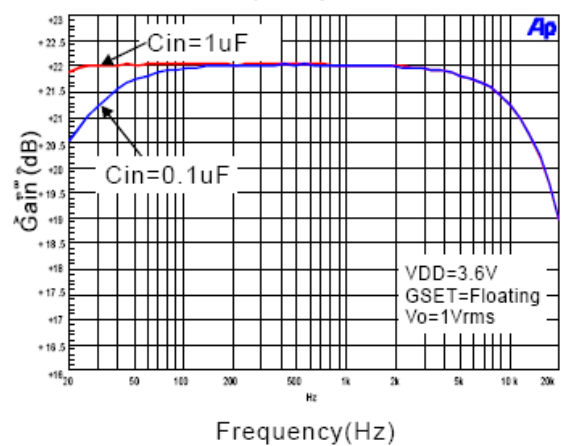

Typical Performance Characteristics (cont.) (@T_A = +25°C, V_{DD} = 3.6V, C_L = 1μF, L = 4.7μH, V_{SET} floating, R_{LOAD} = 10Ω, L_{LOAD} = 22μH with external schottky diode, unless otherwise specified.)

7. Gain VS Frequency

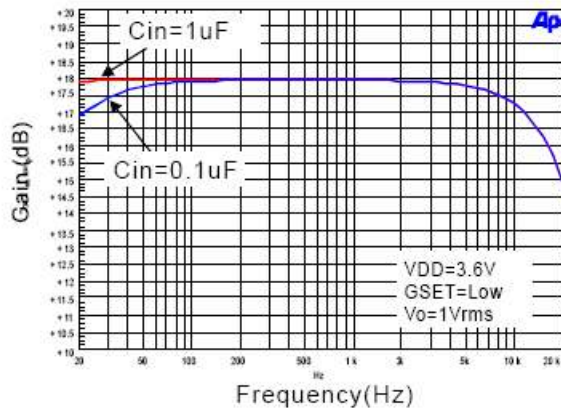

8. THD & Vo VS Input Voltage RMS

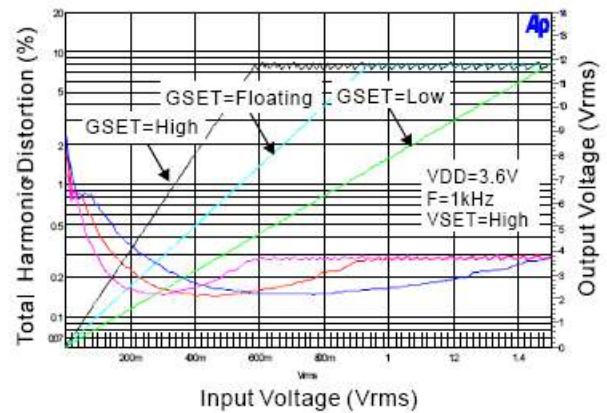

9. THD & Vo VS Input Voltage RMS

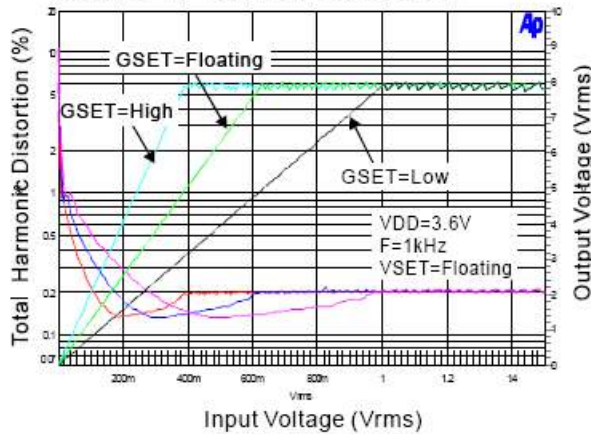

10. THD & Vo VS Input Voltage RMS

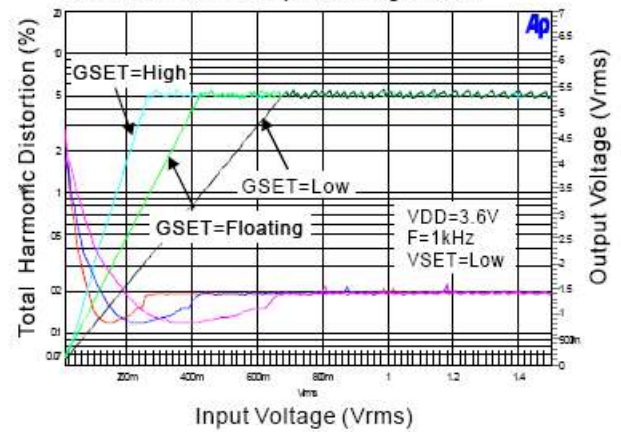

11. Enable

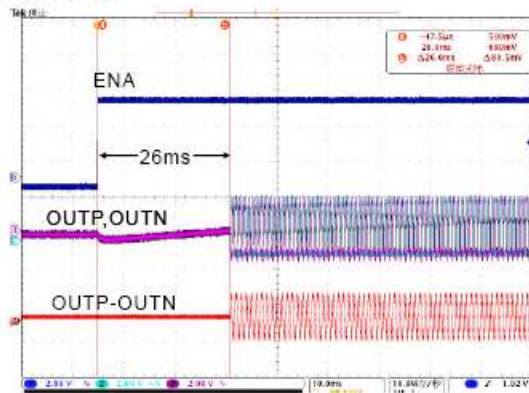

12. Shutdown

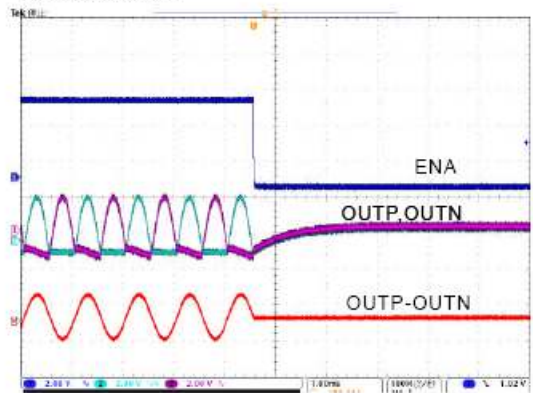

Application Information

Select Boost Converter Output Voltage

Customer can use V_{SET} pin to set boost converter output voltage between 8V, 12V and 17.5V. V_{SET} pin configuration table as below:

V _{SET} Pin Configuration	Min	Max	PVCC Voltage	Audio Amplifier Maximum Output Voltage
High	AVDD – 0.5	AVDD	17.5V	11 V _{RMS} (V _{PP} = 31.1V)
Floating	1V	AVDD – 1V	12V	8 V _{RMS} (V _{PP} = 22.6V)
Low	GND	0.5V	8V	5 V _{RMS} (V _{PP} = 14.1V)

Gain Setting and Input Resistance (R_I)

Gain setting function is only available in disable condition (ENA = low) and need to follow the sequence as pull ENA to low (disable the IC) first, and change the GSET voltage between high, floating, low, then pull ENA to high (enable the IC).

The input resistors (R_I = R_{IN} + R_{EX}) set the gain of the amplifier according to Equation 1 when anti-saturation is inactive.

$$G = 20 \text{ Log} [12.8 * R_F / (R_{IN} + R_{EX})] \text{ (dB)}$$

G _{SET}	R _{IN}	R _{FB}
High	77.4kΩ	122.6kΩ
Floating	100kΩ	100kΩ
Low	122.6kΩ	77.4kΩ

Where R_{IN} is a 77.4kΩ internal resistor, R_{EX} is the external input resistor, R_F is a 122.6kΩ internal resistor. Resistor matching is very important in fully differential amplifiers. The balance of the output on the reference voltage depends on matched ratios of the resistors. CMRR, PSRR, and cancellation of the second harmonic distortion diminish if resistor mismatch occurs. Therefore, it is recommended to use 1% tolerance resistors or better to keep the performance optimized. Matching is more important than overall tolerance. Resistor arrays with 1% matching can be used with a tolerance greater than 1%.

Place the input resistors very close to the PAM8902A to limit noise injection on the high-impedance nodes. For optimal performance the gain should be set to lower. Lower gain allows the PAM8902A to operate at its best, and keeps a high voltage at the input making the inputs less susceptible to noise. In addition to these features, higher value of R_I minimizes pop noise.

Anti-Saturation Function

Anti-saturation is active by detecting the duty cycle of the PWM output. When the mode is detected, the gain is automatically adjusted to the value that the output is not clip step by step. The attack time is 100μs per step and the release time is 186ms per step. Following table shows the anti-saturation variable description.

PAM8902A Anti-Saturation Variable Description

Variable	Description	Value
Gain	The original gain of the device when the Anti-saturation is inactive. The fixed gain is also the initial gain when the device comes out of shutdown mode.	26dB (G _{SET} = High) 22dB (G _{SET} = Floating) 18dB (G _{SET} = Low)
Attenuation Range	The gain control range when trigger anti-saturation function.	-26dB (G _{SET} = High) -22dB (G _{SET} = Floating) -18dB (G _{SET} = Low)
Step Size	Gain adjust step size when attack and release.	0.25dB/Step
Attack Time	The minimum time between two gain decrements.	100μs
Release Time	The minimum time between two gain increments.	186ms

Application Information (cont.)

Input Capacitors (C_I)

In the typical application, an input capacitor, C_I , is required to allow the amplifier to bias the input signal to the proper DC level for optimum operation. In this case, C_I and the minimum input impedance R_I form a high-pass filter with the corner frequency determined in the following equation:

$$f_C = \frac{1}{2\pi R_I C_I}$$

It is important to consider the value of C_I as it directly affects the low frequency performance of the circuit. For example, when R_I is 150k and the specification calls for a flat bass response are down to 150Hz.

Equation is reconfigured as followed:

$$C_I = \frac{1}{2\pi R_I f_C}$$

When input resistance variation is considered, the C_I is 7nF, so one would likely choose a value of 10nF. A further consideration for this capacitor is the leakage path from the input source through the input network (C_I , $R_I + R_F$) to the load. This leakage current creates a DC offset voltage at the input to the amplifier that reduces useful headroom, especially in high gain applications. For this reason, a low-leakage tantalum or ceramic capacitor is the best choice. When polarized capacitors are used, the positive side of the capacitor should face the amplifier input in most applications as the DC level is held at $V_{DD} / 2$, which is likely higher than the source DC level. Please note that it is important to confirm the capacitor polarity in the application.

Decoupling Capacitor

The PAM8902 is a high-performance CMOS audio amplifier that requires adequate power supply decoupling to ensure the output total harmonic distortion (THD) as low as possible.

The optimum decoupling is achieved by using two different types of capacitors that target on different types of noise on the power supply leads. For higher frequency transients, spikes, or digital hash on the line, a good low equivalent series-resistance (ESR) ceramic capacitor, typically 1 μ F is placed as close as possible to the device AVDD pin for the best operation. For filtering lower frequency noise signals, a large ceramic capacitor of 10 μ F or greater placed near the AVDD supply trace is recommended.

External Schottky Diode

Use external schottky diode can get the best driving capability and efficiency.

Since internal power diode has limited driving capability, only in following conditions customer can remove the external schottky diode to reduce the cost.

1. V_{SET} = Low or Floating and C_L less than 1 μ F.
2. The signal frequency less than 4KHz.
3. Haptic application (50–500Hz).

Shutdown Operation

In order to reduce power consumption while not in use, the PAM8902A contains shutdown circuitry amplifier off when a logic low is placed on the ENA pin. By switching the ENA pin connected to GND, the PAM8902A supply current draw will be minimized in idle mode.

Under-Voltage Lock-Out (UVLO)

The PAM8902A incorporates circuitry designed to detect supply voltage. When the supply voltage drops to 2.2V or below, the PAM8902A goes into a state of shutdown, and the device comes out of its shutdown state and restore to normal function only when reset the power supply or ENA pin.

Over-Temperature Protection (OTP)

Thermal protection on the PAM8902A prevents the device from damage when the internal die temperature exceeds +150°C. There is a 15°C tolerance on this trip point from device to device. Once the die temperature exceeds the set point, the device will enter the shutdown state and the outputs are disabled, in this condition both OOUTP and OOUTN will become high impedance. This is not a latched fault. The thermal fault is cleared once the temperature of the die decreased by 30°C. This large hysteresis will prevent motor boating sound well and the device begins normal operation at this point with no external system interaction.

Ordering Information

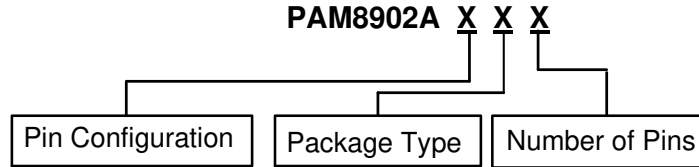

Part Number	Part Marking	Package Type	Standard Package
PAM8902AZER	BN YW	CSP-16L	3000Units/Tape&Reel
PAM8902AKER	P8902A XXXYW	QFN4x4-16L	3000Units/Tape&Reel

Marking Information

16 Ball CSP
Top View

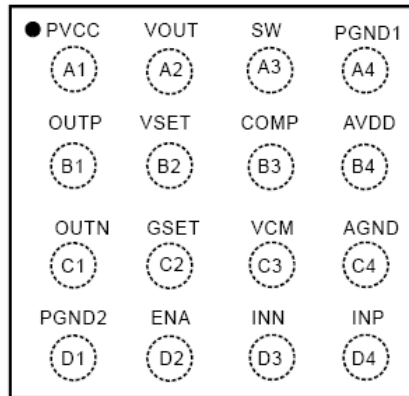

Marking

BN
YW

BN: Product Code of PAM8902A
Y: Year
W: Week

Top View
QFN 4X4 16L

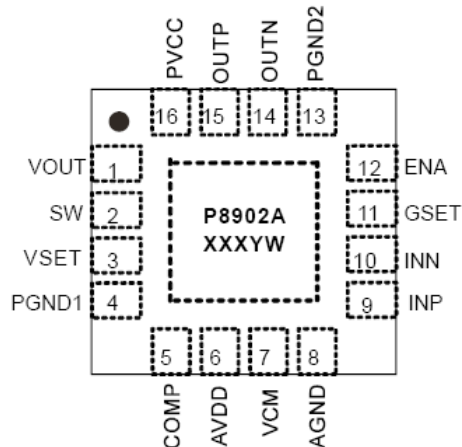

Y: Year
W: Week
X: Internal Code

Package Outline Dimensions (All dimensions in mm.)

CSP-16

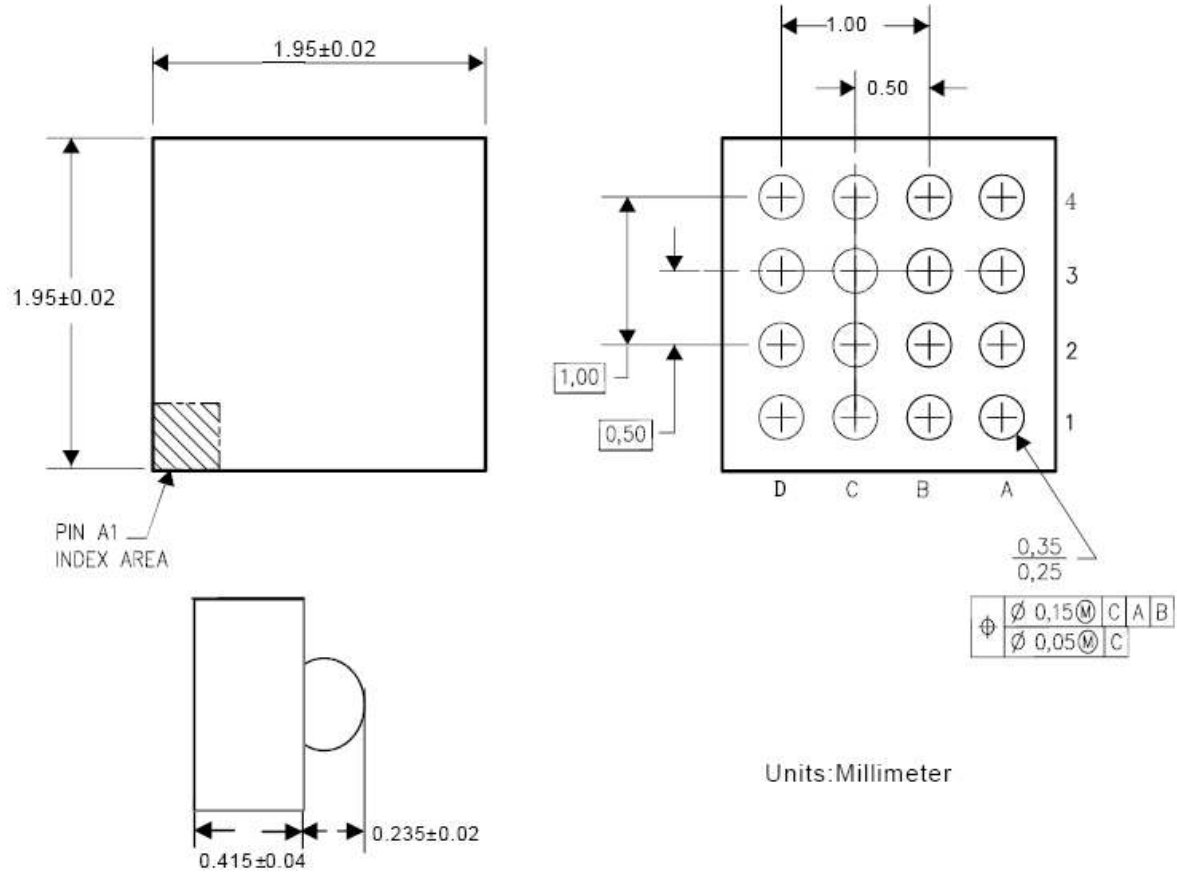

Units: Millimeter

NOT FOR

Package Outline Dimensions (cont.) (All dimensions in mm.)

QFN4x4-16

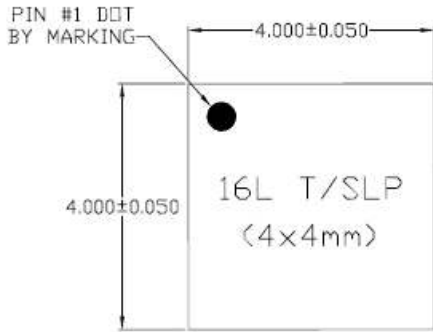

TOP VIEW

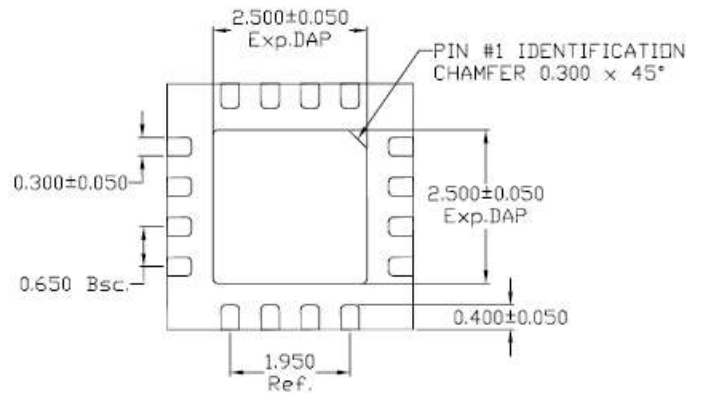

BOTTOM VIEW

NOTE:

1) TSLP AND SLP SHARE THE SAME EXPOSE OUTLINE BUT WITH DIFFERENT THICKNESS:

		TSLP	SLP
A	MAX.	0.800	0.900
	NOM.	0.750	0.850
	MIN.	0.700	0.800

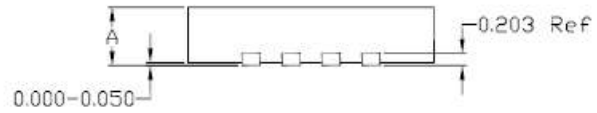

SIDE VIEW

NOT RECOMMENDED FOR NEW DESIGN

IMPORTANT NOTICE

DIODES INCORPORATED MAKES NO WARRANTY OF ANY KIND, EXPRESS OR IMPLIED, WITH REGARDS TO THIS DOCUMENT, INCLUDING, BUT NOT LIMITED TO, THE IMPLIED WARRANTIES OF MERCHANTABILITY AND FITNESS FOR A PARTICULAR PURPOSE (AND THEIR EQUIVALENTS UNDER THE LAWS OF ANY JURISDICTION).

Diodes Incorporated and its subsidiaries reserve the right to make modifications, enhancements, improvements, corrections or other changes without further notice to this document and any product described herein. Diodes Incorporated does not assume any liability arising out of the application or use of this document or any product described herein; neither does Diodes Incorporated convey any license under its patent or trademark rights, nor the rights of others. Any Customer or user of this document or products described herein in such applications shall assume all risks of such use and will agree to hold Diodes Incorporated and all the companies whose products are represented on Diodes Incorporated website, harmless against all damages.

Diodes Incorporated does not warrant or accept any liability whatsoever in respect of any products purchased through unauthorized sales channel. Should Customers purchase or use Diodes Incorporated products for any unintended or unauthorized application, Customers shall indemnify and hold Diodes Incorporated and its representatives harmless against all claims, damages, expenses, and attorney fees arising out of, directly or indirectly, any claim of personal injury or death associated with such unintended or unauthorized application.

Products described herein may be covered by one or more United States, international or foreign patents pending. Product names and markings noted herein may also be covered by one or more United States, international or foreign trademarks.

This document is written in English but may be translated into multiple languages for reference. Only the English version of this document is the final and determinative format released by Diodes Incorporated.

LIFE SUPPORT

Diodes Incorporated products are specifically not authorized for use as critical components in life support devices or systems without the express written approval of the Chief Executive Officer of Diodes Incorporated. As used herein:

- A. Life support devices or systems are devices or systems which:
1. are intended to implant into the body, or
 2. support or sustain life and whose failure to perform when properly used in accordance with instructions for use provided in the labeling can be reasonably expected to result in significant injury to the user.
- B. A critical component is any component in a life support device or system whose failure to perform can be reasonably expected to cause the failure of the life support device or to affect its safety or effectiveness.

Customers represent that they have all necessary expertise in the safety and regulatory ramifications of their life support devices or systems, and acknowledge and agree that they are solely responsible for all legal, regulatory and safety-related requirements concerning their products and any use of Diodes Incorporated products in such safety-critical, life support devices or systems, notwithstanding any devices- or systems-related information or support that may be provided by Diodes Incorporated. Further, Customers must fully indemnify Diodes Incorporated and its representatives against any damages arising out of the use of Diodes Incorporated products in such safety-critical, life support devices or systems.

Copyright © 2012, Diodes Incorporated

www.diodes.com