

PRODUCT NUMBER	TAIL PLATING OPTION, SEE NOTE 2	DESCRIPTION
10112626-101	OPTION 1	WITHOUT STOPS
10112626-101LF	OPTION 2	WITHOUT STOPS
10112626-102	OPTION 1	WITH STOPS
10112626-102LF	OPTION 2	WITH STOPS

NOTES:

- MATERIALS:**
CONNECTOR HOUSING: HIGH TEMPERATURE THERMOPLASTIC
GLASS FILLED, UL 94V-0
EMI CAGE: NICKEL SILVER ALLOY
EMI FINGERS: COPPER ALLOY
TERMINALS: COPPER ALLOY
- FINISHES:**
EMI FINGERS: 0.50µm MIN NICKEL
CONTACT AREA: 0.76µm MIN GOLD OVER 2.54µm MIN NICKEL
TAIL AREA:
OPTION 1: 0.76µm - 1.52µm TIN/LEAD (90/10) OVER 2.54µm MIN NICKEL
OPTION 2: 0.76µm - 1.52µm TIN (LEAD FREE) OVER 2.54µm MIN NICKEL
- PRODUCT SPECIFICATION:** GS-12-651
APPLICATION SPECIFICATION: GS-20-0327
- MOUNTING HARDWARE:** M2X0.4 BUTTON HEAD SCREW
MOUNTING SCREW LENGTH: BOARD THICKNESS + 1.4mm MAX (0.9mm MIN).
1 REQUIRED PER ASSEMBLY
- THIS CONNECTOR IS DESIGNED TO MEET THE REQUIREMENTS OF INDUSTRY SPECIFICATION SFF-8644.
- THE USE OF A PCI BRACKET OR EQUIVALENT IS REQUIRED FOR THIS PRODUCT
- A \triangle SYMBOL WILL BE NEXT TO ANY DIMENSION, VIEW, OR NOTE THAT HAS BEEN MODIFIED WITH THE CURRENT DRAWING REVISION.

MATES WITH MINI-SAS HD ENDS IN:
10112041 SERIES (4X)
10117771 SERIES (4X)
10117946 SERIES (4X)
10117949 SERIES (4X)

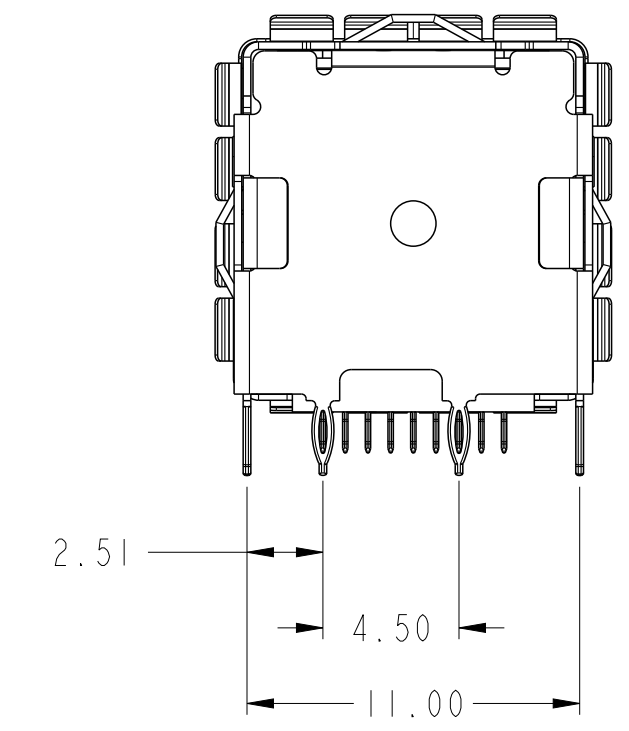
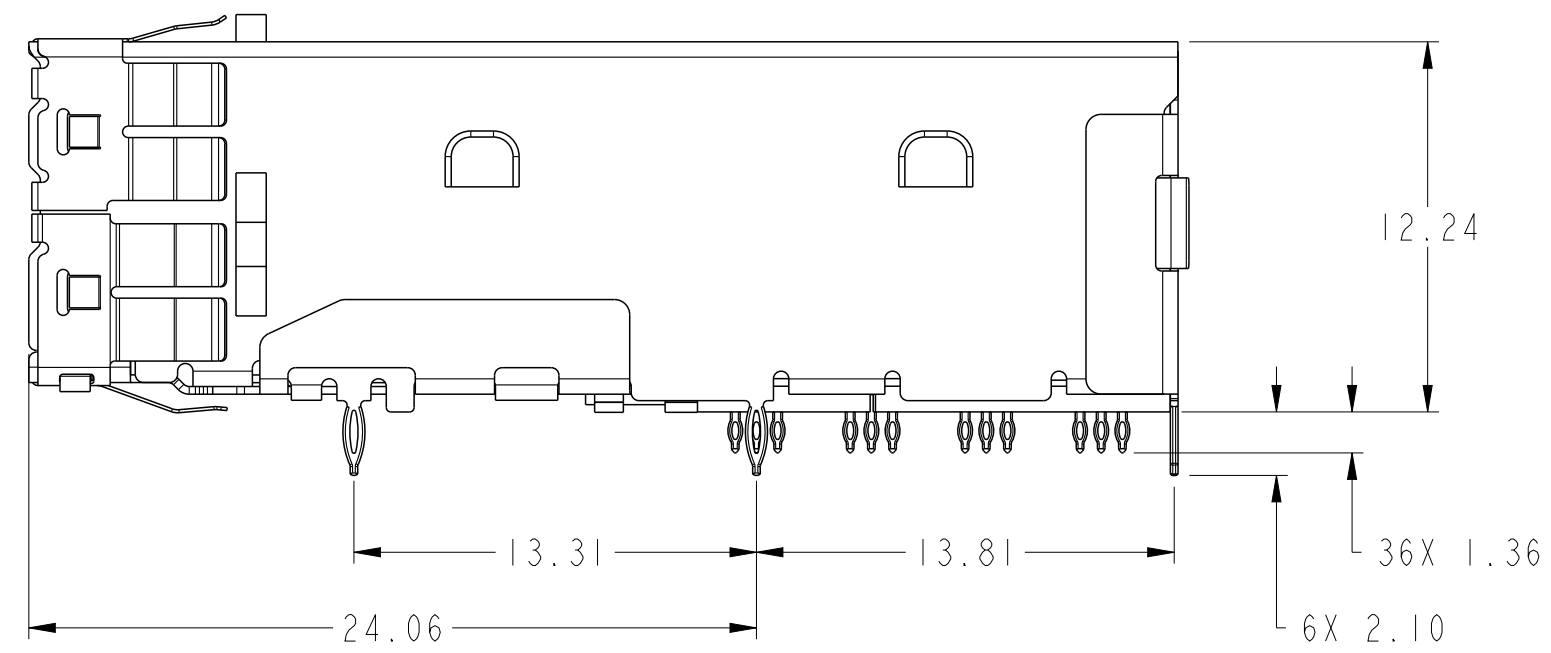
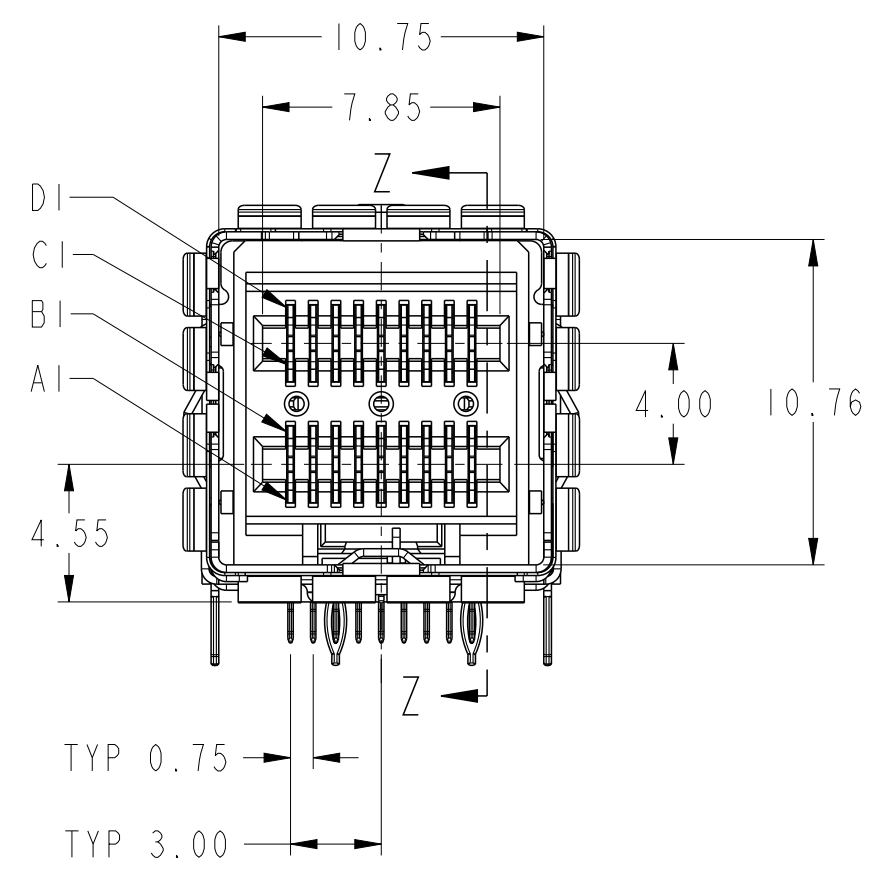
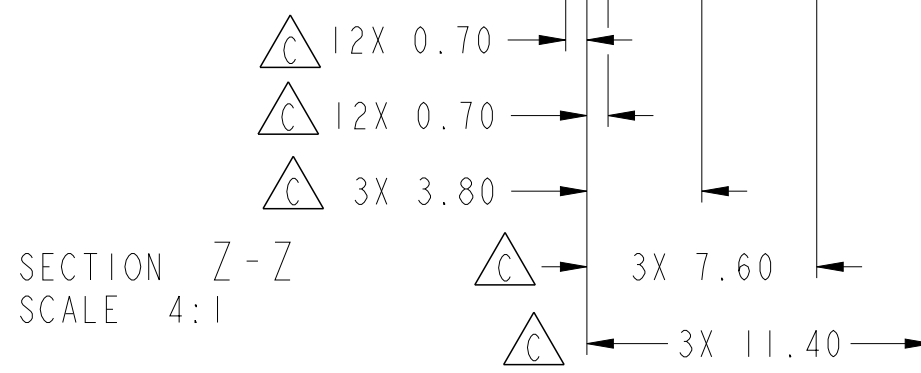
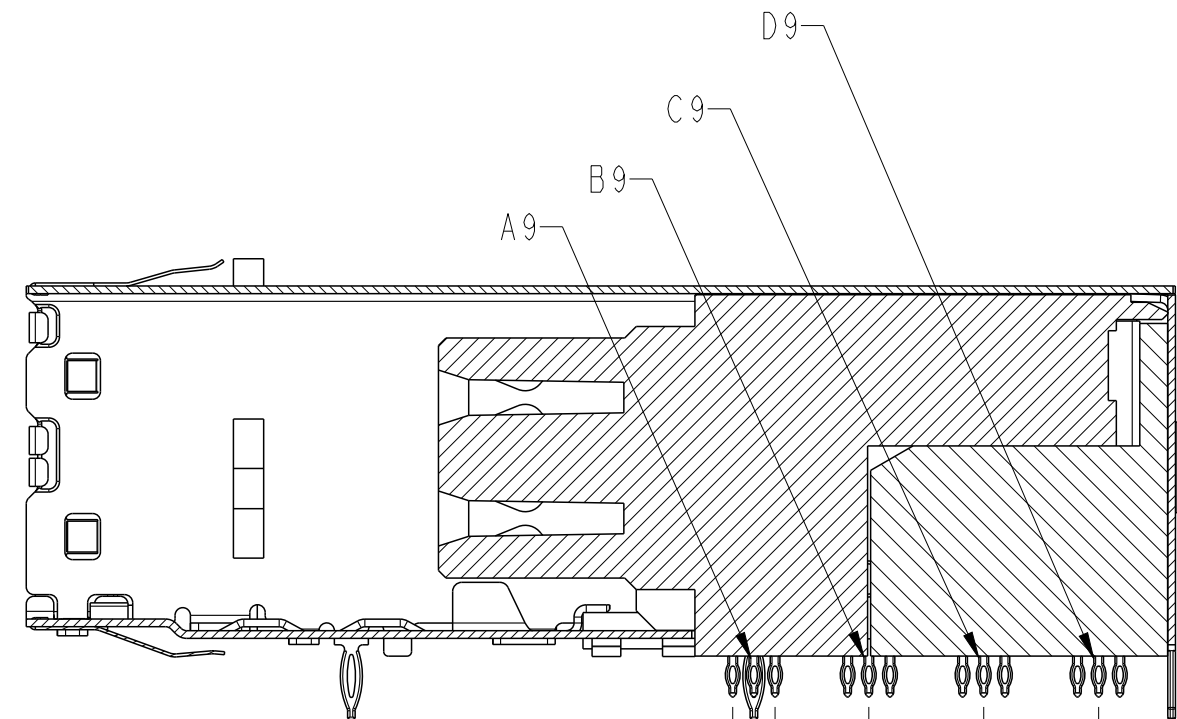
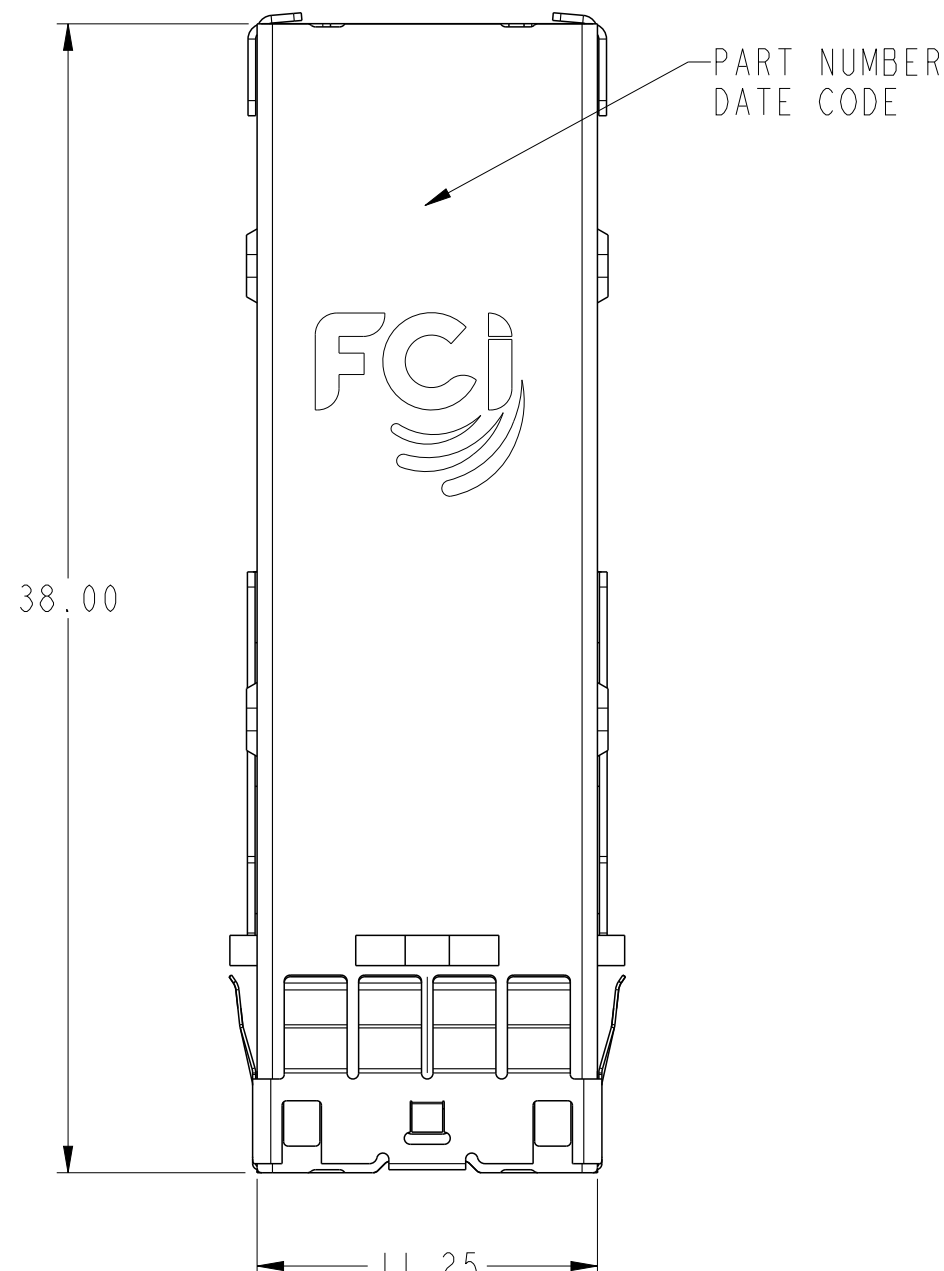

spec ref	-	dr	Mark Gray	2010/08/04	projection	MM	size	A2	scale	4:1
tolerance std	ASME Y14.5	eng	M Scholeno	2012/09/10	chr	-	ecn no	ELX-V-012260-1	rel level	Released
surface	✓	appr	Brad Brubaker	2012/09/12	product family	MINI-SAS HD	cat. no.	10112626	rev	C
ASME Y14.5	linear	0.X	±0.25	0.XX	±0.13	0.XXX	±	angular	0°	±1/2°

APPLICATION	DIM A
PCI ADD-IN CARD	19.00 ± 0.15
ALL OTHER APPLICATIONS	20.08 ± 0.15

I/O BRACKET CUT OUT
(BRACKET NOT SUPPLIED)
SEE NOTE 6

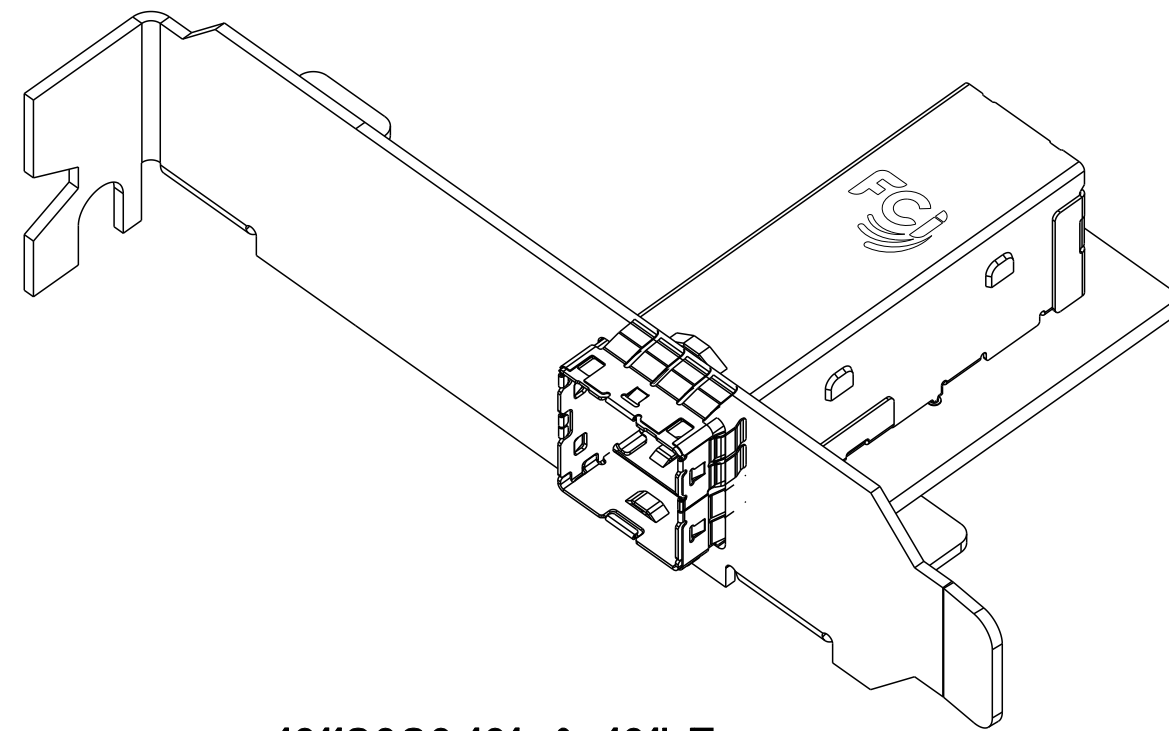

10112626-101 & 101LF
WITHOUT STOPS
SCALE 2:1

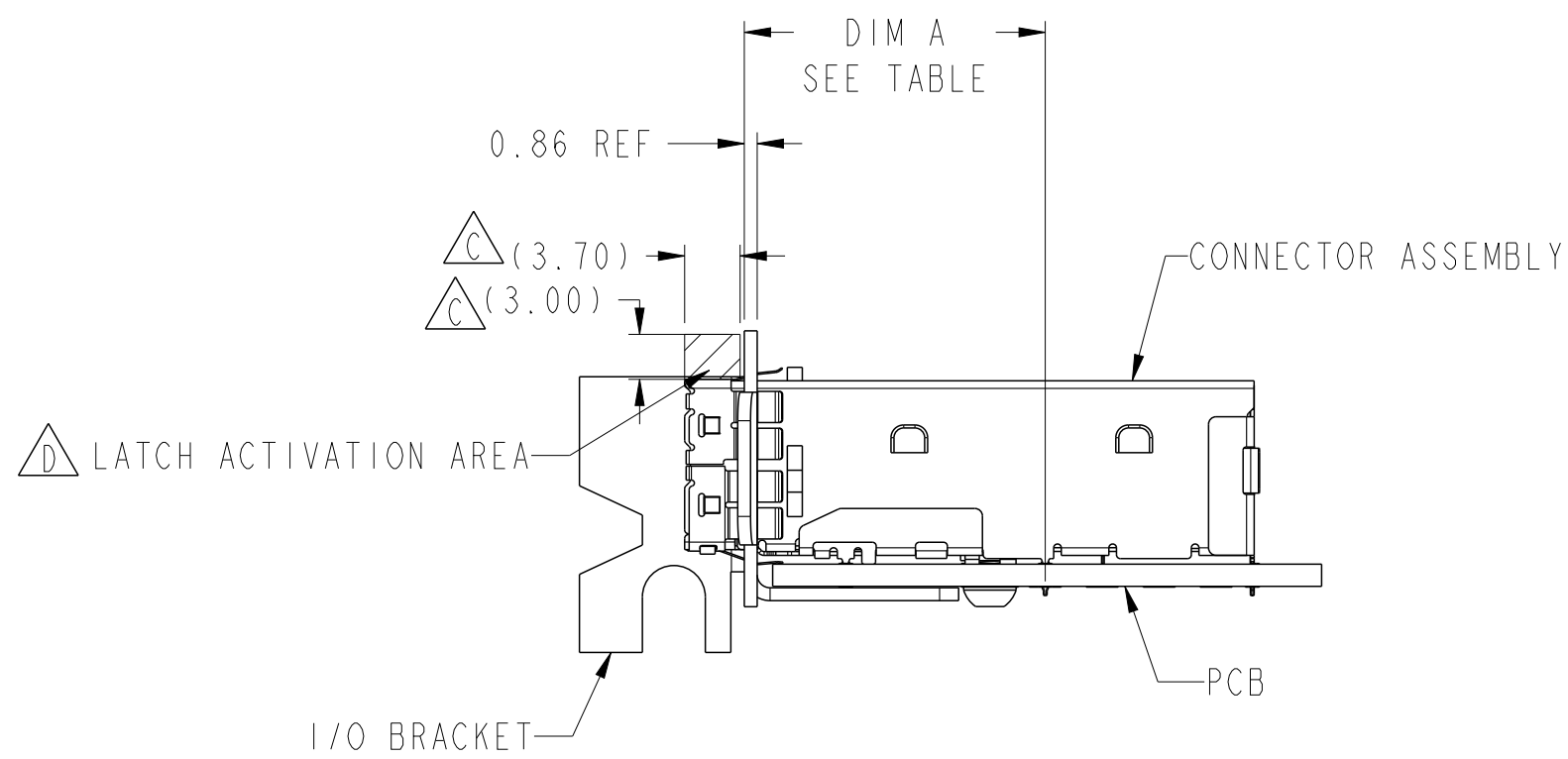

ASSEMBLED VIEW
WITHOUT STOPS
SCALE 2:1

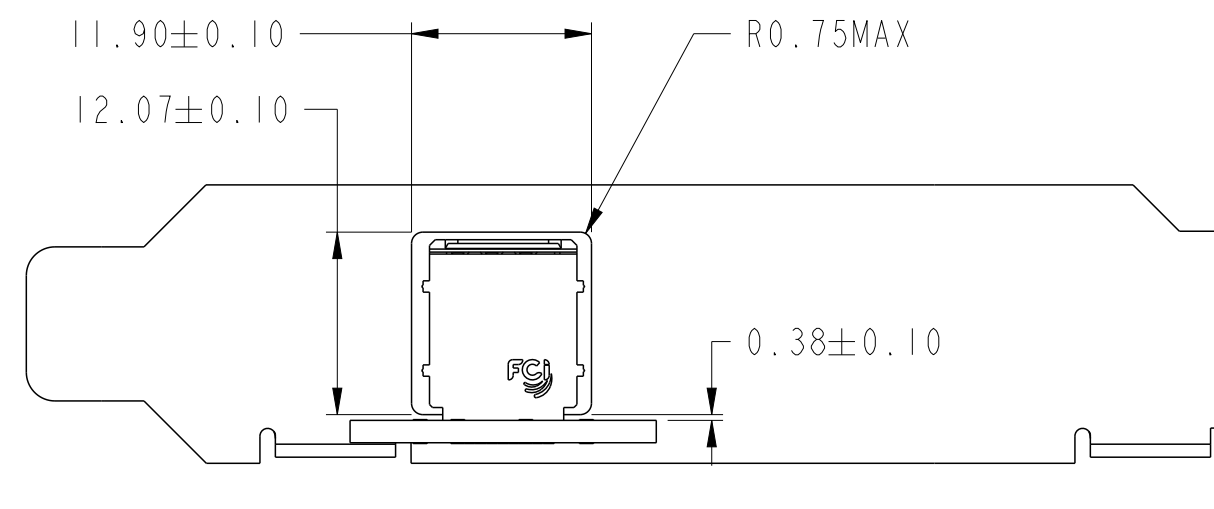

spec ref	-	dr	Mark Gray	2010/08/04	projection	MM	size	A2	scale	1:1					
tolerance std	ASME Y14.5	eng	M Scholeno	2012/09/10			ecn no	ELX-V-012260-1	rel level	Released					
TOLERANCES UNLESS OTHERWISE SPECIFIED		chr	-	product family							MINI-SAS HD				
surface	✓	appr	Brad Brubaker	2012/09/12	title	I/O EXTERNAL ASSEMBLY		dwg no	10112626	rev	C				
ASME Y14.5	linear	0.X	±0.25	0.XX	±0.13	0.XXX	±	angular	0°	±1/2°	www.fci.com	cat. no.	-	Product - Customer Drw	sheet 2 of 7

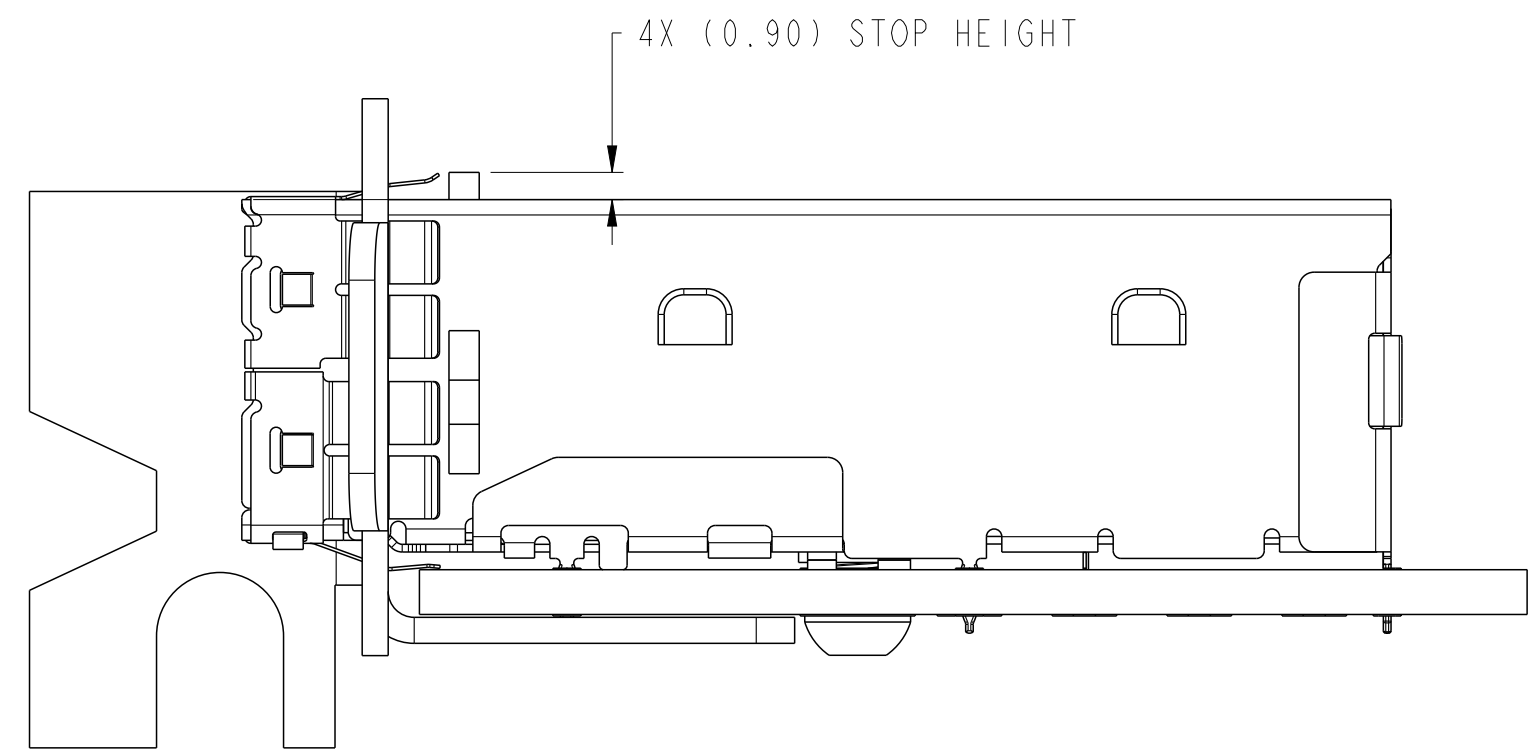

ASSEMBLED VIEW
WITH STOPS
SCALE 4:1

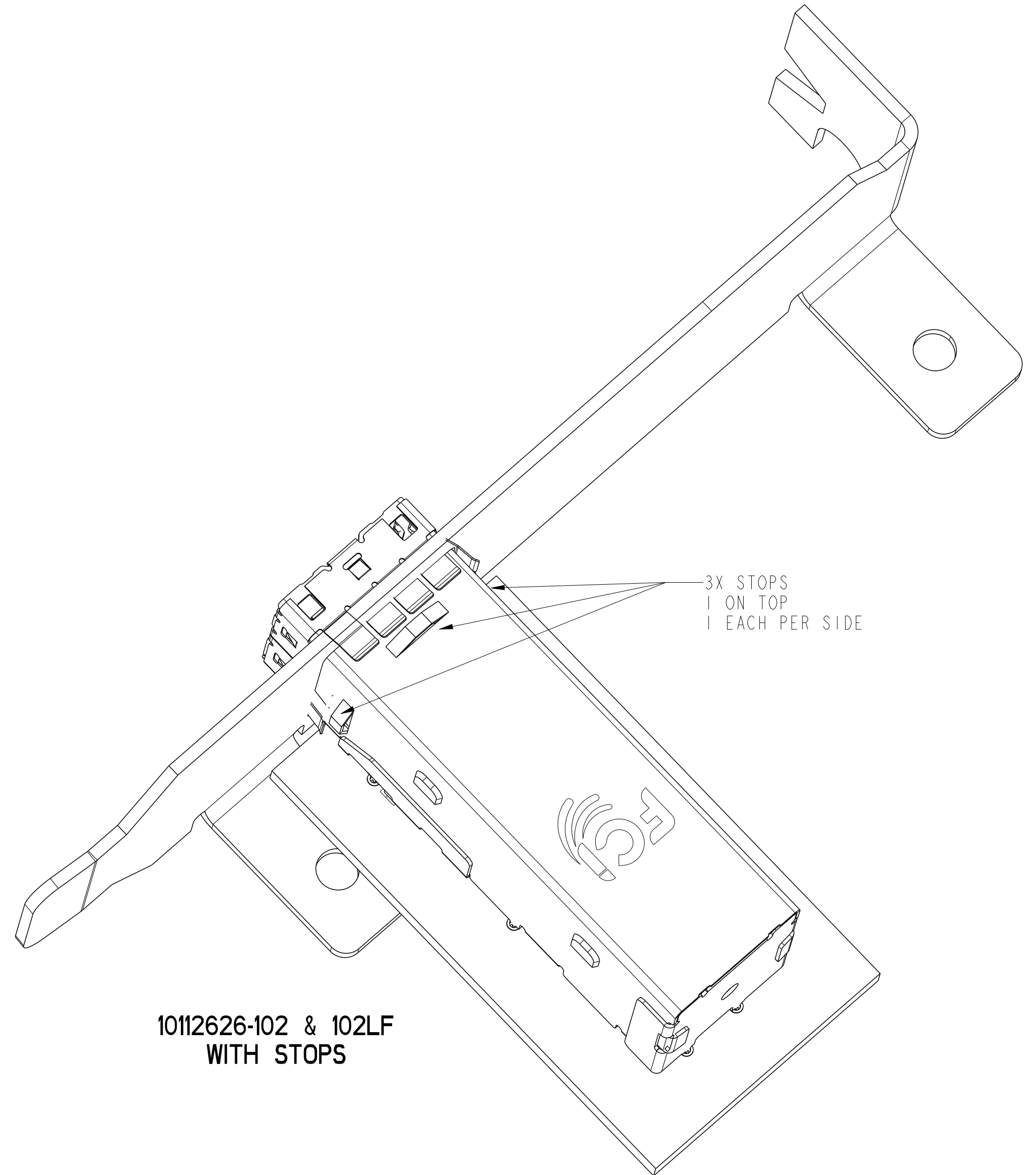

10112626-102 & 102LF
WITH STOPS

Copyright FCI.
FCI

spec ref	-	dr	Mark Gray	2010/08/04	projection	MM	size	A2	scale	1:1	
tolerance std	ASME Y14.5	eng	M Scholeno	2012/09/10			ecn no	ELX-V-012260-1			
TOLERANCES UNLESS OTHERWISE SPECIFIED		chr	-	appr			Brad Brubaker	2012/09/12	product family	MINI-SAS HD	rel level
surface	<input checked="" type="checkbox"/>	linear	0.X	±0.25		title IxI EXTERNAL ASSEMBLY MINI-SAS HD	dwg no 10112626	rev C			
			0.XX	±0.13							
			0.XXX	±							
ASME Y14.5		angular	0°	±1/2°	www.fci.com	cat. no.	-	Product - Customer Drw	sheet 3 of 7		

APPLICATION	DIM B
PCI ADD-IN CARD	17.10 ± 0.15
ALL OTHER APPLICATIONS	18.19 ± 0.15

RECOMMENDED BOARD LAYOUT

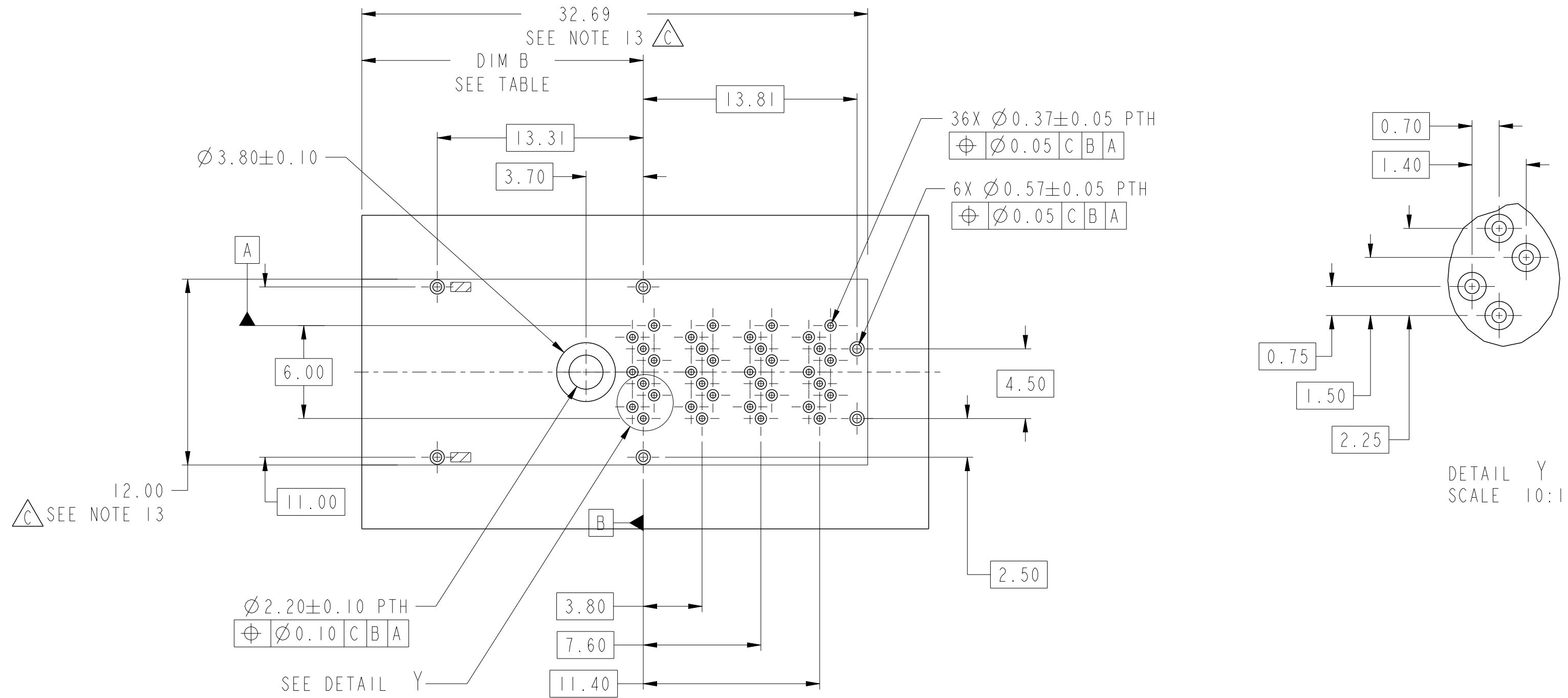

NOTES:

8. RECOMMENDED DRILL SIZE FOR A Ø0.37 FINISHED PTH IS Ø0.457.
9. RECOMMENDED ANNULAR RING AROUND Ø0.37 FINISHED PTH IS Ø0.73.
10. RECOMMENDED DRILL SIZE FOR A Ø0.57 FINISHED PTH IS Ø0.68.
11. RECOMMENDED ANNULAR RING AROUND A Ø0.57 FINISHED PTH IS Ø0.93.
12. MINIMUM RECOMMENDED CENTER TO CENTER SPACING BETWEEN ADJACENT CONNECTORS: 14.00mm
13. CONNECTOR KEEP OUT AREA.
14. MINIMUM PCB THICKNESS: 1.57mm.

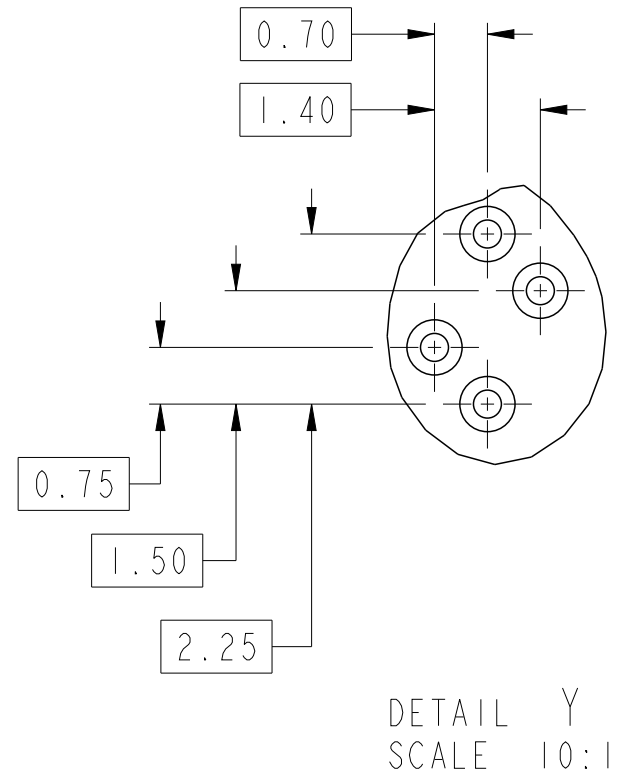
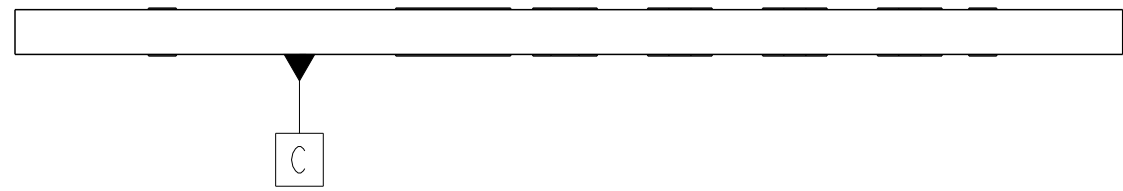

Copyright FCI. FCI

spec ref	-	dr	Mark Gray	2010/08/04	projection	MM	size	A2	scale	1:1	
tolerance std	ASME Y14.5	eng	M Scholeno	2012/09/10			ecn no	ELX-V-012260-1	rel level	Released	
TOLERANCES UNLESS OTHERWISE SPECIFIED		chr	-	apppr							Brad Brubaker
surface	✓	linear	0.X	±0.25		FCI I x I EXTERNAL ASSEMBLY MINI-SAS HD	dwg no 10112626	rev C	Product - Customer Drw		
ASME Y14.5	angular	0°	±1/2°	www.fci.com					cat. no.	Product - Customer Drw	sheet 4 of 7

RECOMMENDED TOOLING KEEP OUT AREAS

RECOMMENDED INSERTION TOOL
KEEP OUT AREA
NO COMPONENTS IN THIS AREA
MORE THAN 7.50mm TALL

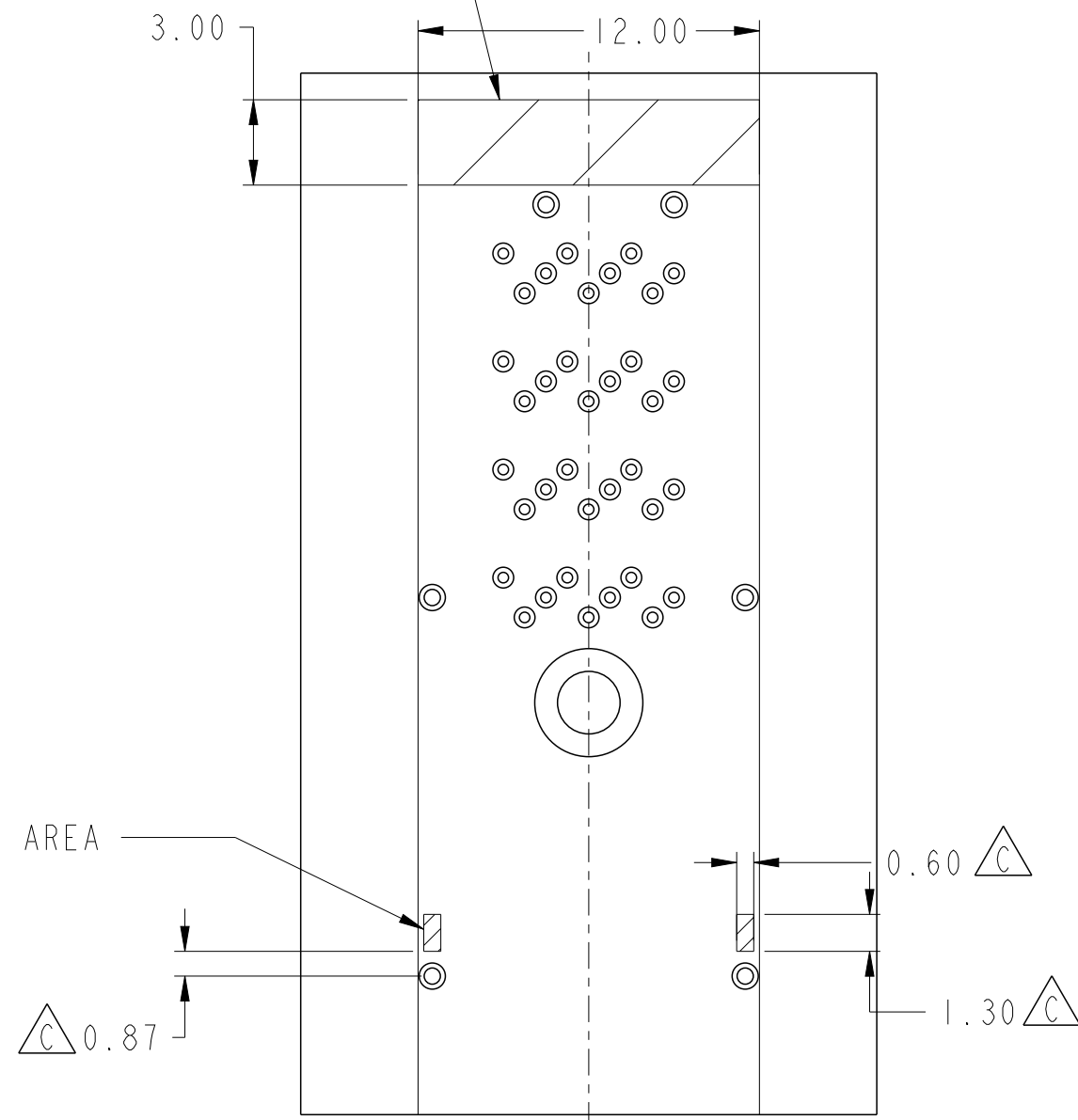

RECOMMENDED EXTRACTION TOOL
KEEP OUT AREA
NO COMPONENTS IN THESE AREAS

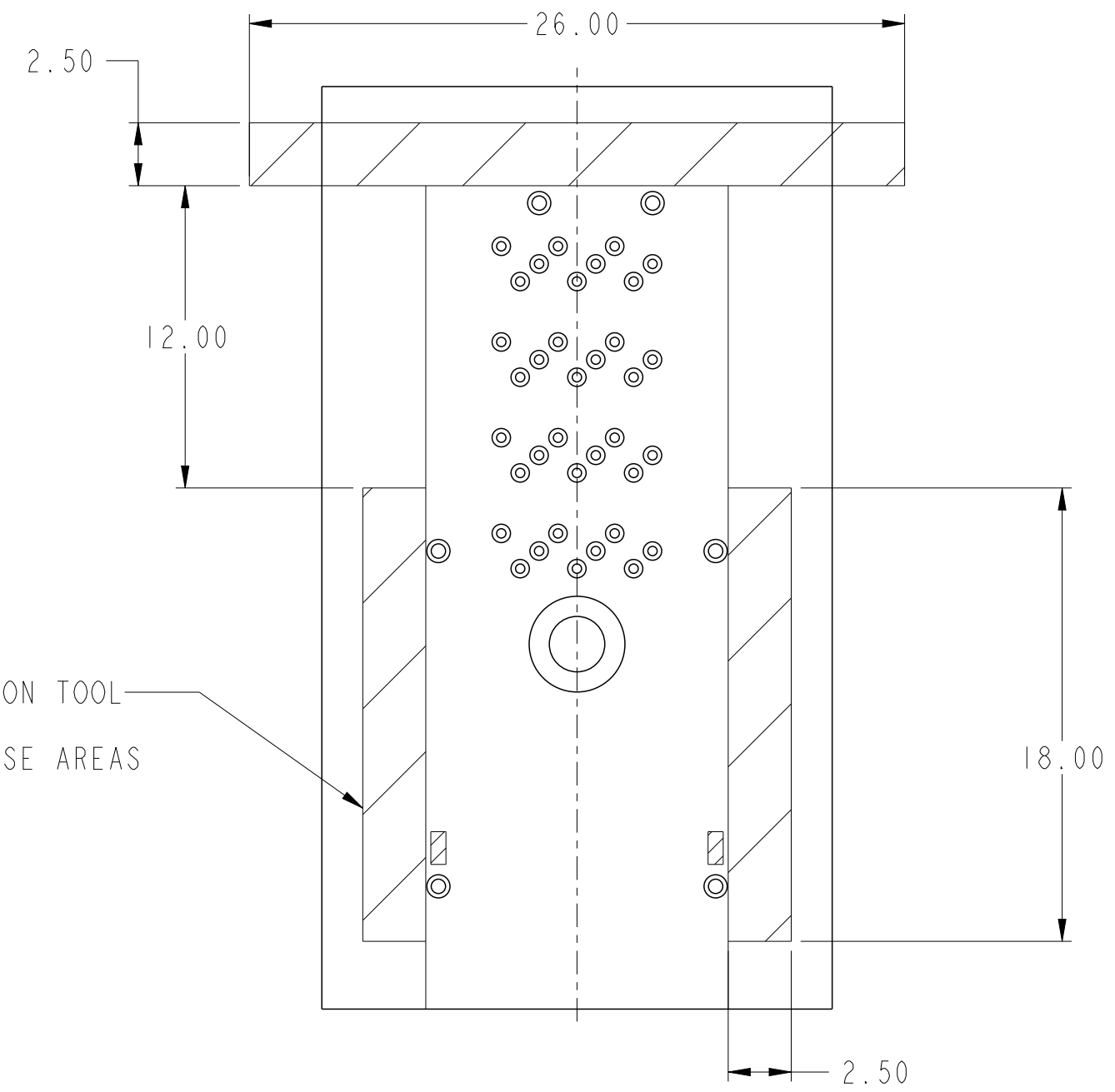

Copyright FCI.
FCI

spec ref	-	dr	Mark Gray	2010/08/04	projection	MM	size	A2	scale	1:1
tolerance std	ASME Y14.5	eng	M Scholeno	2012/09/10	chr	-	ecn no	ELX-V-012260-1	rel level	Released
TOLERANCES UNLESS OTHERWISE SPECIFIED		appr	Brad Brubaker	2012/09/12	product family	MINI-SAS HD	rel level	Released		
surface	linear	0.X	±0.25	FCI	title	IxI EXTERNAL ASSEMBLY	dwg no	10112626	rev	C
		0.XX	±0.13							
		0.XXX	±							
ASME Y14.5	angular	0°	±1/2°	www.fci.com	cat. no.	-	Product - Customer Drw	sheet 5 of 7		

PIN OUT DESIGNATIONS

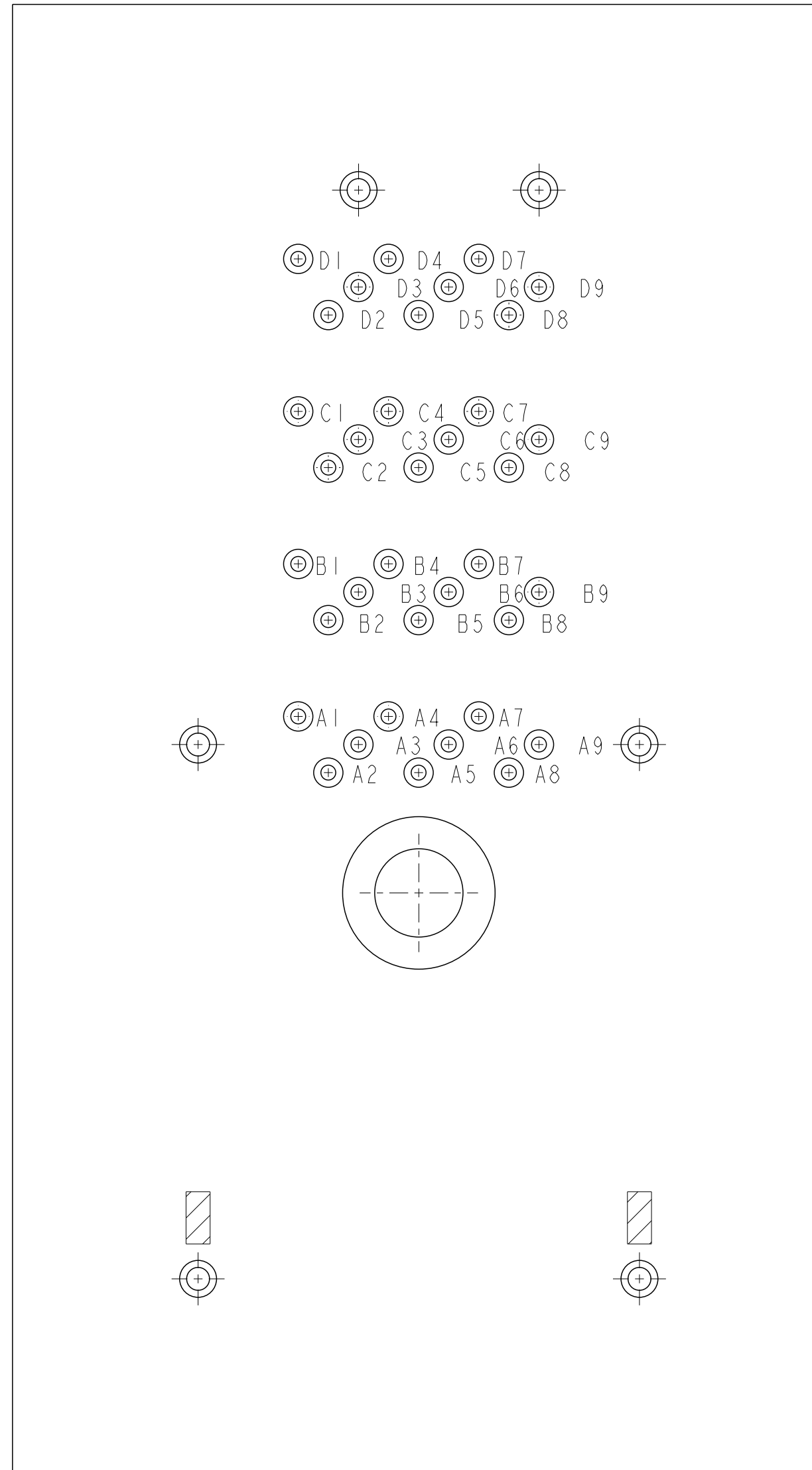

spec ref	-	dr	Mark Gray	2010/08/04	projection	MM	size	A2	scale	1:1
tolerance std	ASME Y14.5	eng	M Scholeno	2012/09/10	chr	-	ecn no	ELX-V-012260-1	rel level	Released
surface	✓	appr	Brad Brubaker	2012/09/12	product family	MINI-SAS HD	cat. no.	10112626	rev	C
ASME Y14.5	linear	0.X	±0.25	0.XX	±0.13	0.XXX	±	angular	0°	±1/2°
		www.fci.com		title		IXI EXTERNAL ASSEMBLY		Product - Customer Drw		sheet 6 of 7

PDS: Rev :C

STATUS:Released

Printed: Sep 13, 2012



Copyright FCI.

A
B
C
D
E
F

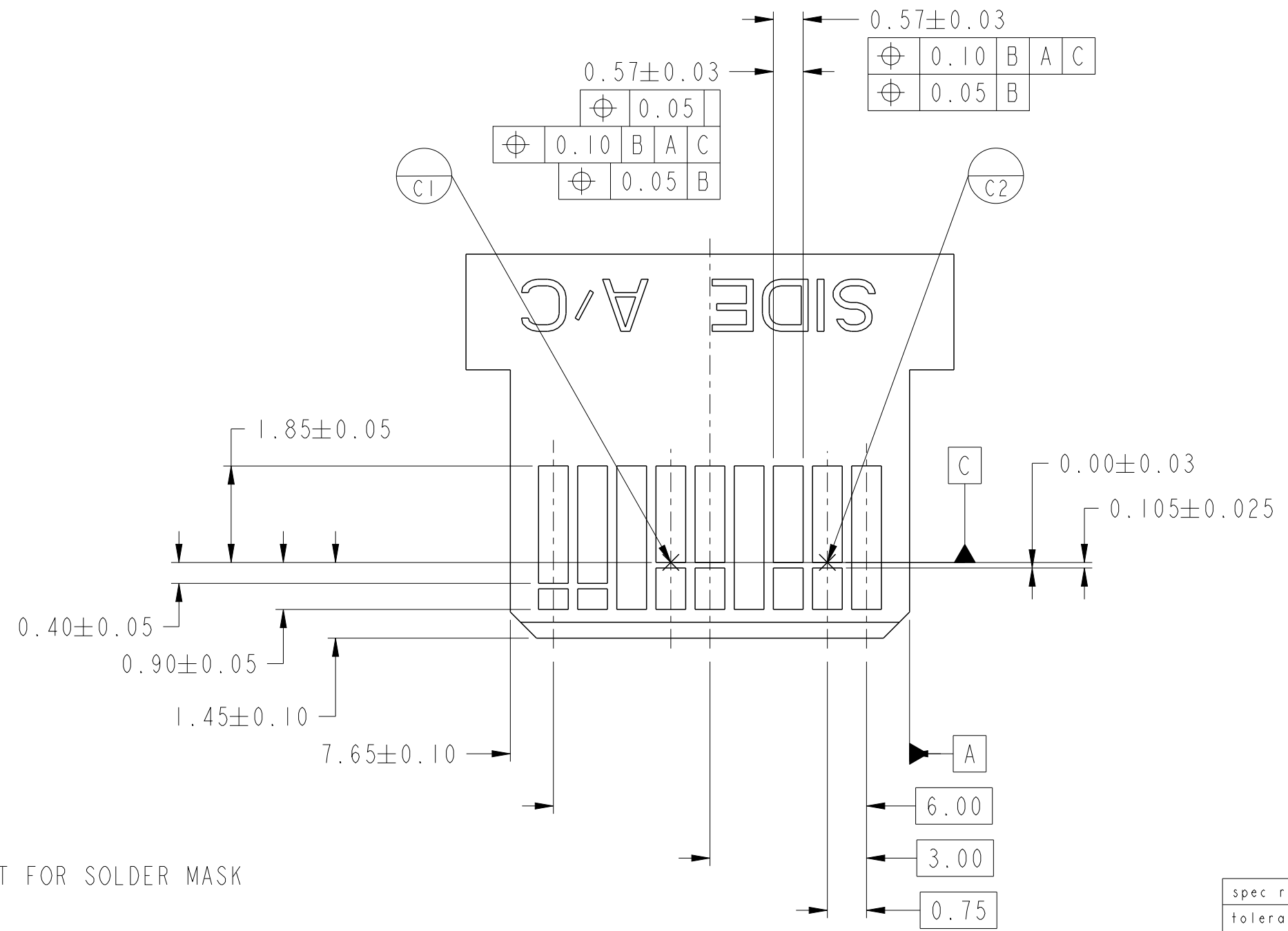
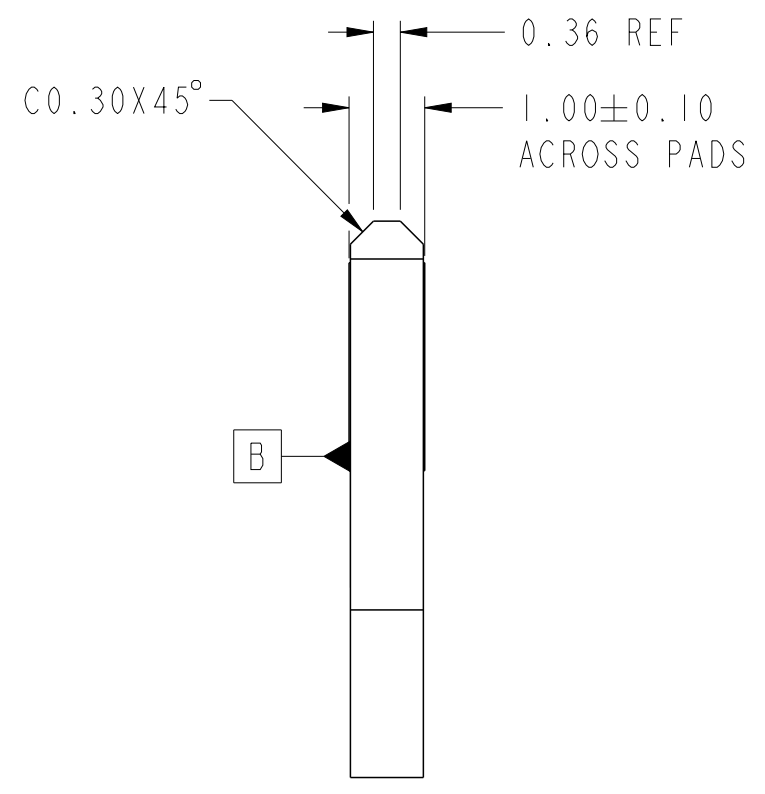
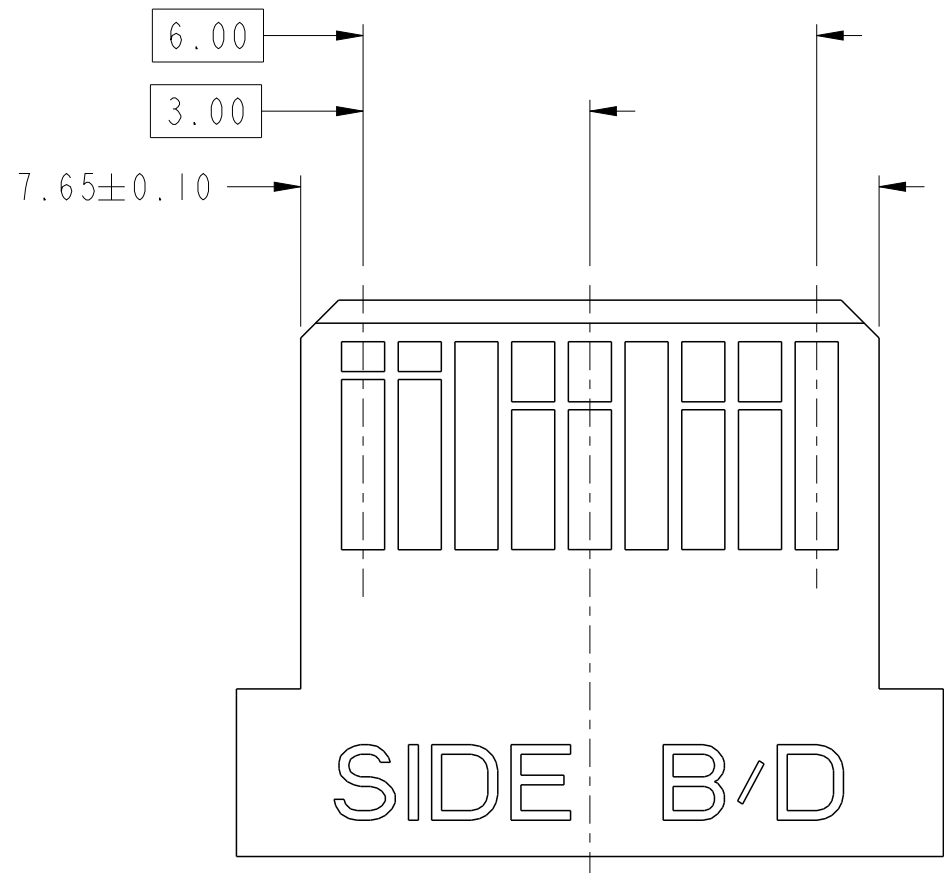

- NOTES:
- 0.05 MINIMUM KEEP OUT FOR SOLDER MASK AROUND ALL PADS.
 - DATUM D TARGETS ARE DEFINED BY THE RESPECTIVE PAD CENTER LINES AND THE LEADING EDGE OF THE TARGET PADS.

spec ref	-	dr	Mark Gray	2010/08/04	projection	MM	size	A2	scale	1:1
tolerance std	ASME Y14.5	eng	M Scholeno	2012/09/10	chr	-	ecn no	ELX-V-012260-1	rel level	Released
surface	✓	appr	Brad Brubaker	2012/09/12	product family	MINI-SAS HD	cat. no.	10112626	rev	C
ASME Y14.5	linear	0.X	±0.25	0.XX	±0.13	0.XXX	±-	angular	0°	±1/2°

Copyright FCI.
FCI