

## Absolute maximum ratings

( $T_a=25^\circ\text{C}$ )

Symbol	Ratings	Unit
$V_{DSS}$	250	V
$V_{GSS}$	$\pm 20$	V
$I_D$	$\pm 7$	A
$I_D(\text{pulse})$	$\pm 15$ ( $PW \leq 1\text{ms}$ , $D_u \leq 1\%$ )	A
$E_{AS}^*$	55	mJ
$P_T$	4 ( $T_a=25^\circ\text{C}$ , with all circuits operating, without heatsink)	W
	35 ( $T_c=25^\circ\text{C}$ , with all circuits operating, with infinite heatsink)	W
$\theta_{j-a}$	31.2 (Junction-Air, $T_a=25^\circ\text{C}$ , with all circuits operating)	$^\circ\text{C}/\text{W}$
$\theta_{j-c}$	3.57 (Junction-Case, $T_c=25^\circ\text{C}$ , with all circuits operating)	$^\circ\text{C}/\text{W}$
$T_{ch}$	150	$^\circ\text{C}$
$T_{stg}$	-40 to +150	$^\circ\text{C}$

\* :  $V_{DD}=25\text{V}$ ,  $L=2.0\text{mH}$ ,  $I_D=7\text{A}$ , unclamped,  $R_G=50\Omega$ , see Fig. E on page 15.

## Electrical characteristics

( $T_a=25^\circ\text{C}$ )

Symbol	Specification			Unit	Conditions
	min	typ	max		
$V_{(BR)DSS}$	250			V	$I_D=100\mu\text{A}$ , $V_{GS}=0\text{V}$
$I_{GSS}$			$\pm 100$	nA	$V_{GS}=\pm 20\text{V}$
$I_{DSS}$			100	$\mu\text{A}$	$V_{DS}=250\text{V}$ , $V_{GS}=0\text{V}$
$V_{TH}$	2.0		4.0	V	$V_{DS}=10\text{V}$ , $I_D=1\text{mA}$
$R_{e(yfs)}$	2.5	5.0		S	$V_{DS}=10\text{V}$ , $I_D=3.5\text{A}$
$R_{DS(ON)}$		0.4	0.5	$\Omega$	$V_{GS}=10\text{V}$ , $I_D=3.5\text{A}$
$C_{iss}$		450		pF	$V_{DS}=10\text{V}$ , $f=1.0\text{MHz}$ , $V_{GS}=0\text{V}$
$C_{oss}$		280		pF	$I_D=3.5\text{A}$ , $V_{DD} \div 100\text{V}$ , $R_L=28.6\Omega$ , $V_{GS}=10\text{V}$ , see Fig. 3 on page 16.
$td(\text{on})$		20		ns	
$tr$		30		ns	
$td(\text{off})$		55		ns	
$t_f$		75		ns	
$V_{SD}$		1.0	1.5	V	$I_{SD}=7\text{A}$ , $V_{GS}=0\text{V}$
$t_{rr}$		600		ns	$I_{SD}=\pm 100\text{mA}$

## Equivalent circuit diagram

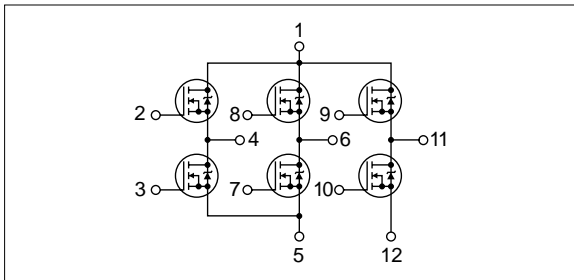

$I_D$ - $V_{DS}$  Characteristics (Typical)

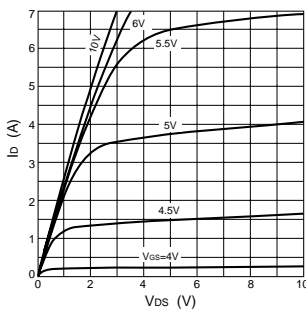

$I_D$ - $V_{GS}$  Characteristics (Typical)

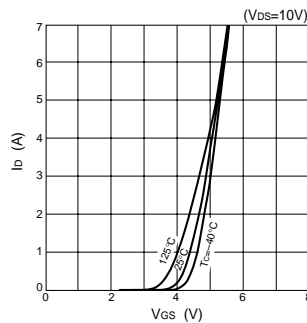

$R_{DS(ON)}$ - $I_D$  Characteristics (Typical)

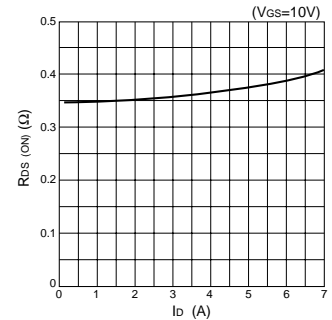

$R_{e(yfs)}$ - $I_D$  Characteristics (Typical)

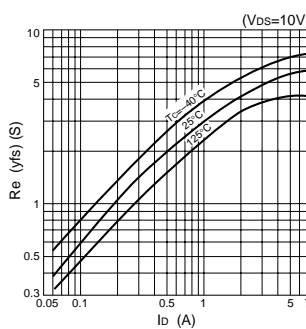

$R_{DS(ON)}$ - $T_C$  Characteristics (Typical)

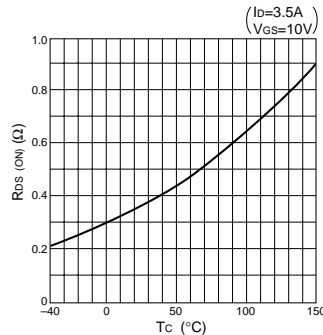

Capacitance- $V_{DS}$  Characteristics (Typical)

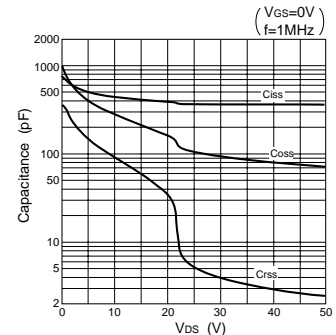

$I_{DR}$ - $V_{SD}$  Characteristics (Typical)

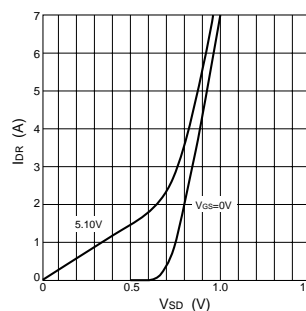

Safe Operating Area (SOA)

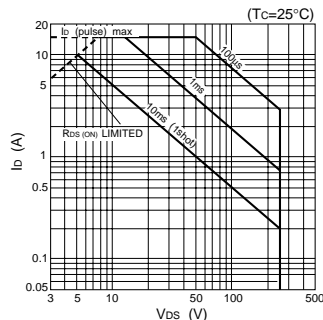

$P_T$ - $T_a$  Characteristics

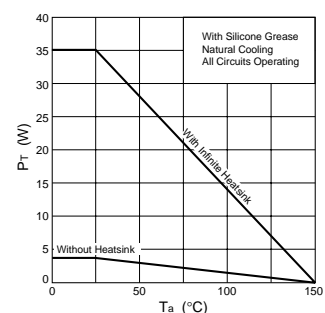

• SIP 8 (STA8Pin)

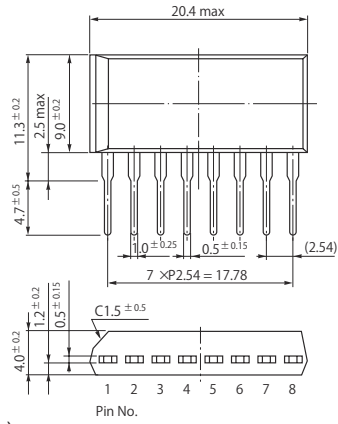

• SIP 10 (STA10Pin)

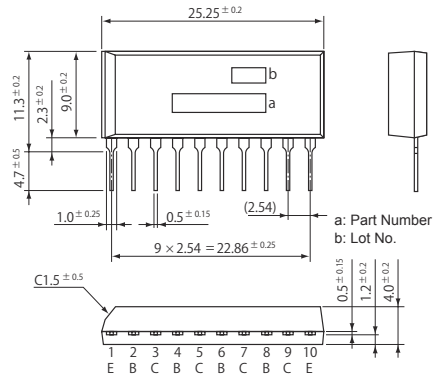

• SIP 12 (SMA12Pin)

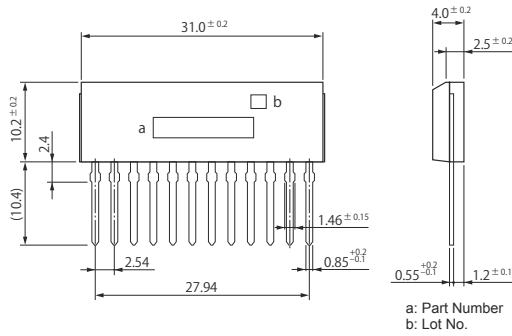

• SIP 15 (SMA15Pin)

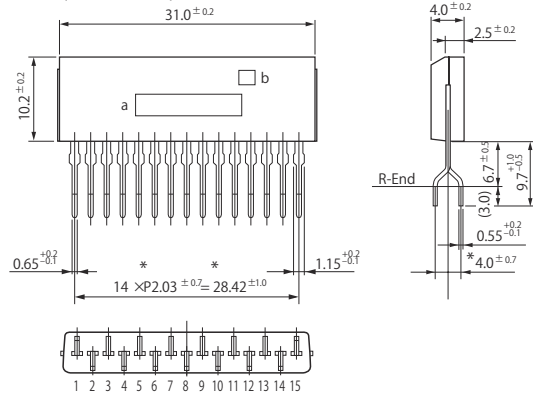

• SIP 12 with Fin (SLA12Pin)

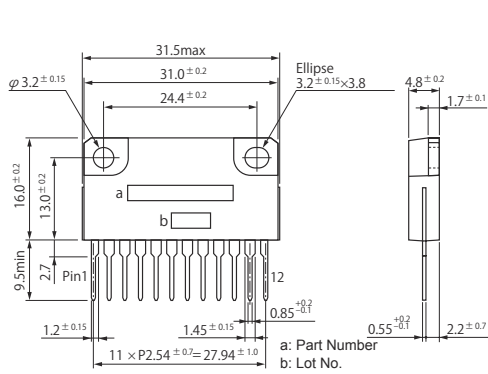

• SIP 15 with Fin (SLA15Pin)

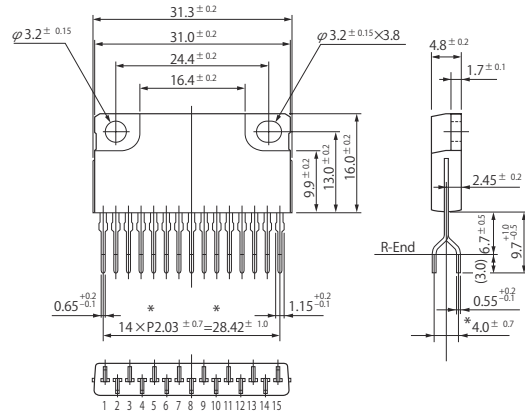

• SIP 21 with Fin (SLA21Pin)

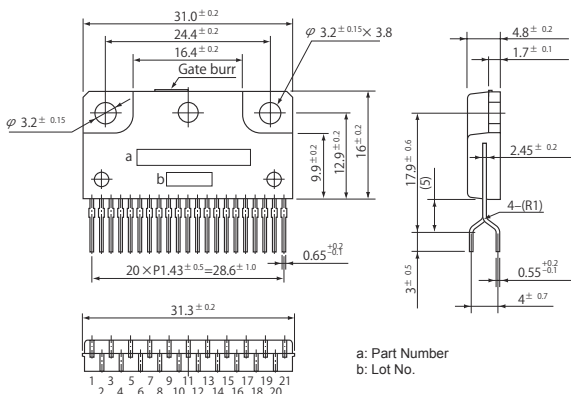

(Unit:mm)