



ANATECH ELECTRONICS INC
RF & Microwave Filters & Products

15350-15750 MHz Bandpass Filter

Part Number: AE15550B10783



Electrical specifications

Passband: 15350-15750MHz
Passband Insertion Loss: ≤1.0 dB (F0)
Passband Ripple: ≤0.5dB
Return Loss: ≥14 dB @ 15350-15400 MHz
 ≥14 dB @ 15700-15750 MHz
 ≥19.5 dB @ 15400-15700 MHz
Rejection: ≥50 dB @ 11000MHz
 ≥40 dB @ 20000MHz
Power Handling: 150W(Max)
Input / Output Impedance: 50 Ohms

Mechanical

Connector Type: N-Female/N-Male
Dimensions: 3.15 x 1.25 x 1 inches

Environmental

Operating Temperature: 0 to +60 deg.C

Outline Drawing:

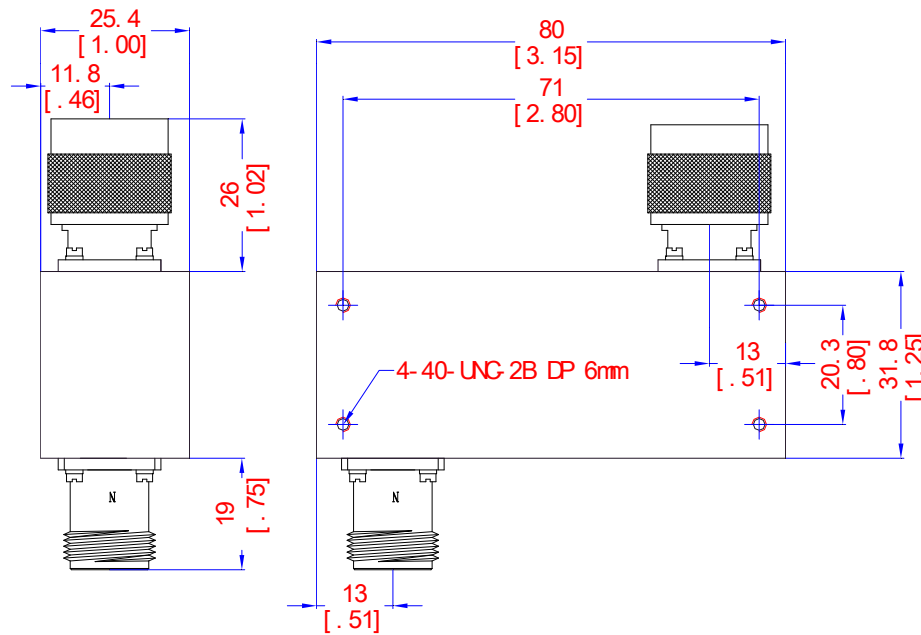

Tolerance: +/-0.01 inches [+/-0.3mm]

Angles: +/-1 Deg.

*Tolerance as shown unless otherwise specified in the datasheet electrical specification tables above.

*When max dimensions are called out the above tolerances do not apply as long as it is under the max call out.