

PART NUMBER	REV	FIRST USED
466794-1	B	122500-1
466794-2	F	565435-5

OBsolete

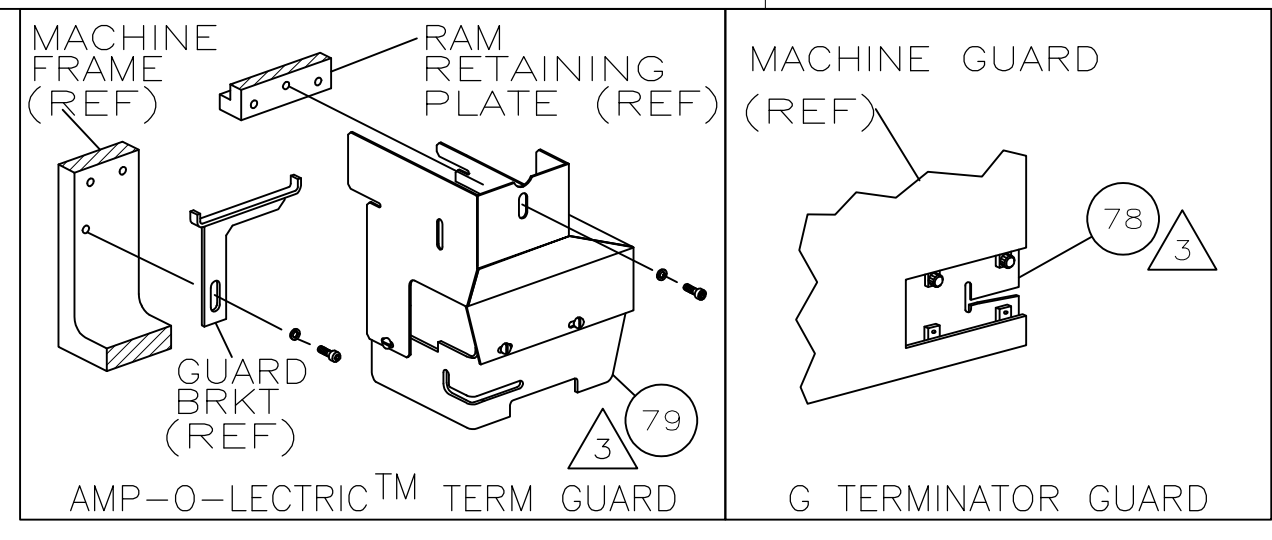

TERMINAL NAME: SPRING SPADE		AMP TERMINAL		AMP CRIMP SPECS	
62795		PAD LTR	CRIMP HEIGHT	WIRE SIZE	
1742106		A	.117 ±.002 [2.97 ±0.05mm]	12	
		B	.106 ±.002 [2.69 ±0.05mm]	14	
		C	.099 ±.002 [2.51 ±0.05mm]	16	
		D	.095 ±.002 [2.41 ±0.05mm]	18	
		CRIMP	SIZE	RANGE	
		WIRE	.140 [3.56mm]	F 18-12	
		INSUL	.210 [5.33mm]	0 .110-.150	
WIRE STRIP LENGTH	TERM APPL SPEC	FEED	APPL INSTRUCTION	SET UP GAGE	LAYOUT
.180-.210	114-2084	.855	408-8039	458638-1	1047

LOC	DIST	REVISIONS			
A	66	REV	DESCRIPTION	DATE	BY
		F	ECR-07-013958	6-2007	MY GB

REV	DESCRIPTION	MECH POST FEED
-1	LEADMAKER & BENCH MODEL G	MECH POST FEED
-2	BENCH MODEL K	MECH POST FEED

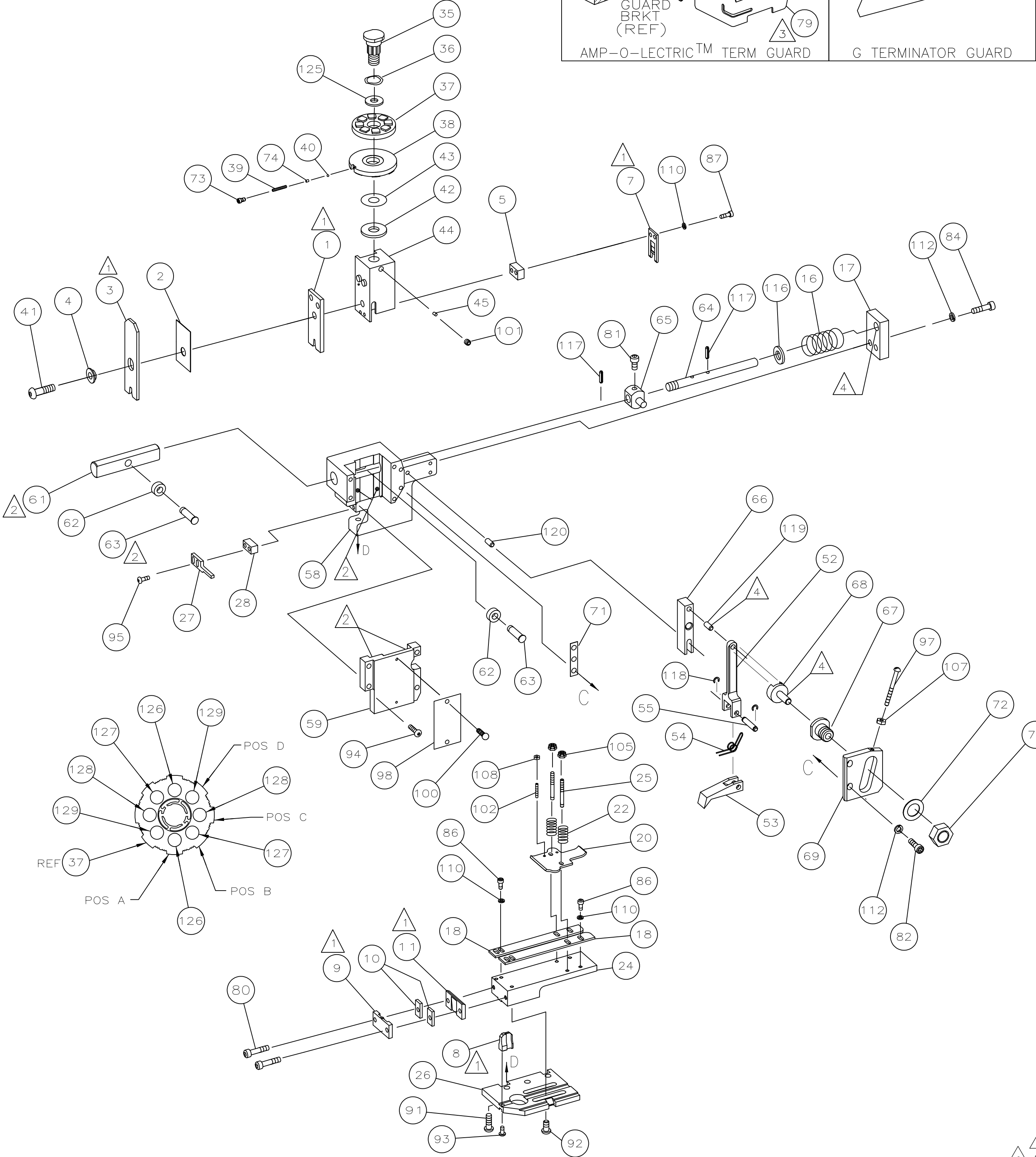

QTY	REV	DESCRIPTION	ITEM NO	
2	2	5-354778-7	PIN, WIRE DISC (.2780)D	129
2	2	5-354778-1	PIN, WIRE DISC (.2750)C	128
2	2	3-354778-3	PIN, WIRE DISC (.2660)B	127
2	2	1-354778-4	PIN, WIRE DISC (.2565)A	126
1	1	986950-1	WASHER, FLAT PRECISION	125
1	1	217238-1	GENERAL INSTRUCTION PACKAGE	124
1	1	4088039	EF APPL INST 408-8039	123
				122
				121
REF	REF	1-21030-7	PIN,DOWEL(Ø.187x1.50)HSG	120
REF	REF	1-21030-1	PIN,DOWEL(Ø.187x.50)LEVER	119
REF	REF	21045-3	RING,RET"C"(Ø.187)FD PIN	118
REF	REF	5-21028-1	PIN,STD SPRING(Ø.12)FD ADJ ROD	117
REF	REF	21899-4	WASHER,FLAT(Ø5/16)SCR ADJ	116
				115
				114
				113
REF	REF	21024-5	WASHER,LOCK(NO.10)FD ROD GDE	112
				111
6	6	21024-4	WASHER,LOCK(NO.8)SHEAR BL	110
				109
2	2	21018-4	NUT,HEX(4-40)DRAG	108
REF	REF	21018-5	NUT,HEX(6-32)FD ADJ PL	107
				106
2	2	21022-2	NUT,HEX SL(8-32)DRAG STUD	105
				104
				103
2	2	2-21006-6	SCR,SKT SET(4-40x.62)DRAG	102
1	1	21009-2	SCR,SKT SET(1/4-20x.25 )RAM	101
2	2	21017-2	SCR,DRIVE(#2x.19)ID PLATE	100
1	1	1-21002-7	SCR,BHC(6-32x.38)CAM	99
1	1	461264-1	PLATE, IDENTIFICATION	98
REF	REF	6-23715-5	SCR,PAN HD(6-32x1.50)FEED ADJ	97
				96
2	2	2-21002-2	SCR,BHC(8-32x.50)STRIPPER	95
REF	REF	2-21002-9	SCR,BHC(10-32x.75)HSG CAP	94
1	1	22733-8	SCR,BHC(8-32x.38 LW)ANVIL	93
4	4	3-21002-3	SCR,BHC(1/4-20x.50)ST GD PL	92
REF	REF	2-22733-8	SCR,BHC(1/4-20x.62)BASE PL	91
				90
				89
				88
2	2	2-21000-7	SCR,SHC(8-32x.50)SLUG BLADE	87
4	4	2-21000-6	SCR,SHC(8-32x.38)STRIP GUIDE	86
				85
REF	REF	3-21000-7	SCR,SHC(10-32x.75)FEED ROD GDE	84
				83
REF	REF	3-21000-6	SCR,SHC(10-32x.62)FEED ADJ PL	82
REF	REF	3-21000-4	SCR,SHC(10-32x.38)PIVOT BLOCK	81
2	2	3-21000-8	SCR,SHC(10-32x.88)SHEAR PL	80
REF	REF	455745-1	GUARD, WINDOW	79
REF	REF	679532-1	INSERT, GUARD	78
				77
				76
				75
1	1	690603-1	SPRING, ASSIST	74
1	1	23030-1	SCR,SKT CAP(6-32x.25)CP DSC	73
REF	REF	458109-1	WASHER, FLAT (SPECIAL)	72
REF	REF	690517-1	SPACER	71

6 3 3

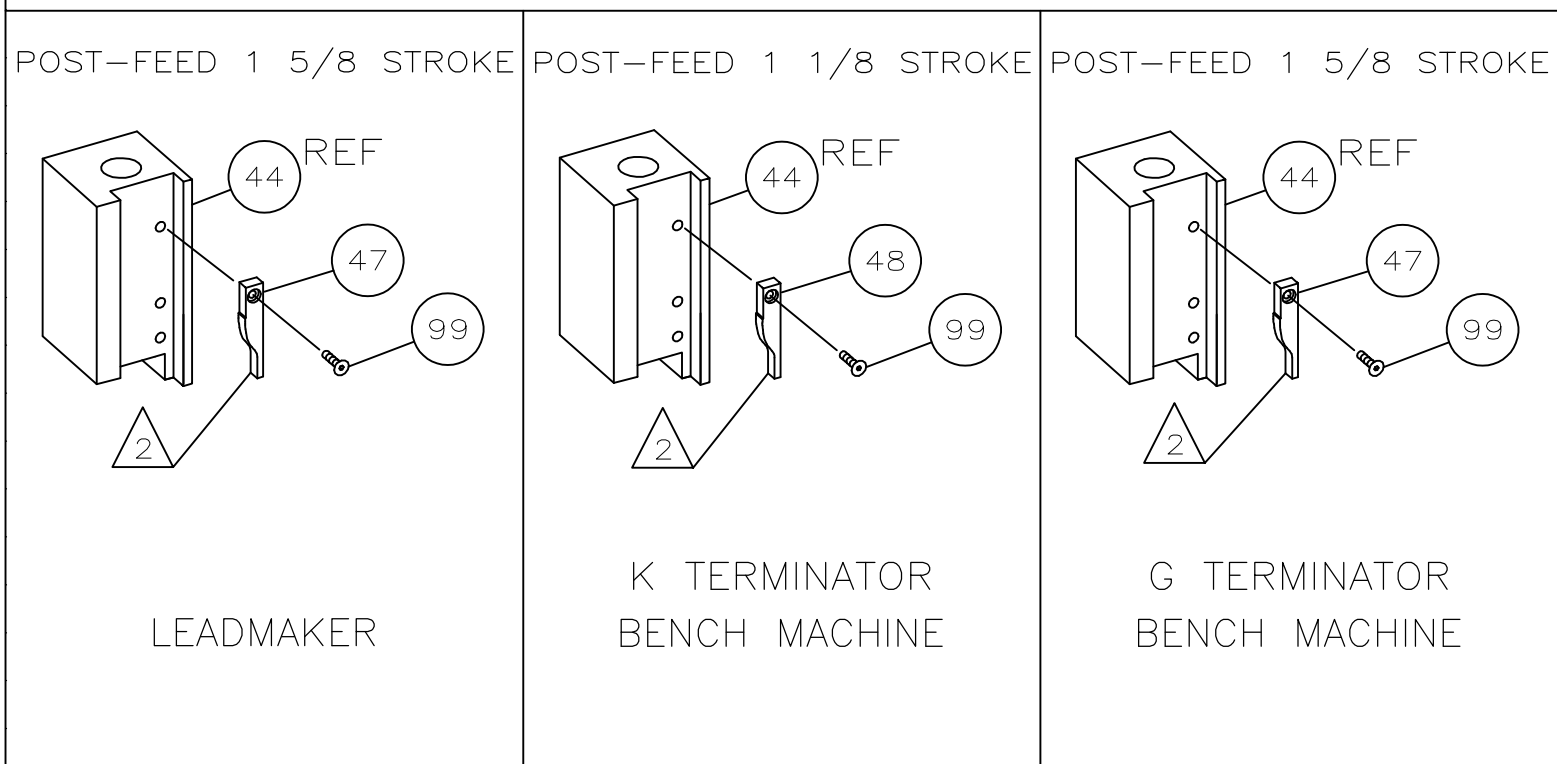

- 1 RECOMMENDED SPARE PARTS.
- 2 GREASE LIGHTLY.
- 3 GUARD MUST BE IN PLACE WHEN OPERATING APPLICATOR IN A BENCH MACHINE.
- 4 LUBRICATE DAILY USING NO. 20 MACHINE OIL.
- 5. ITEMS WITH QTY OF REF SPECIFIED (EXCEPT ITEMS 78 AND 79) ARE USED ON ITEM 32.
- 6 ITEM 78 USED WITH G TERMINATOR ONLY.

OBS

REV	DESCRIPTION	ITEM NO		
REF	REF	22594-8	NUT, HEX	70
REF	REF	240628-1	PLATE, ADJ	69
REF	REF	240626-1	SHAFT, PIVOT	68
REF	REF	240633-1	BUSHING	67
REF	REF	455680-1	LEVER, INTERMEDIATE	66
REF	REF	240629-1	BLOCK, PIVOT	65
REF	REF	240632-2	SCR, ADJ	64
REF	REF	240659-3	PIN, CAM ROLLER	63
REF	REF	240658-1	CAM, ROLLER	62
REF	REF	454398-1	ROD, FEED	61
				60
REF	REF	454220-1	CAP, RAM	59
REF	REF	453736-1	HOUSING	58
				57
				56
REF	REF	240624-1	PIN, FEED FINGER	55
REF	REF	691499-1	SPRING, FEED FINGER	54
REF	REF	240635-1	FINGER, FEED	53
REF	REF	240634-1	LEVER, TERMINAL	52
				51
				50
				49
1		690501-3	CAM, POST FEED 1 1/8 ST	48
		690501-4	CAM, POST-FEED 1 5/8 ST	47
				46
1		690191-1	PLUG, NYLON	45
1		455674-1	RAM	44
1		690125-1	WASHER, LAMINATED	43
1		690124-1	WASHER, RAM	42
1		7-21002-9	BOLT, CRIMPER(5/16-24x1.00)	41
1		23241-6	BALL, STEEL	40
1		690170-1	SPRING, COMPRESSION	39
1		690142-1	DISC, INSULATION	38
1		354777-1	WIRE DISC, PLASTIC	37
1		22480-5	WASHER, SPRING	36
1		690212-1	POST, RAM	35
				34
				33
1		458980-1	APPLICATOR, BASIC (SUB ASSY)	32
				31
				30
				29
1		3-690451-2	SPACER, STRIPPER	28
1		240639-1	STRIPPER	27
REF	REF	455676-1	PLATE, BASE	26
2	2	22354-8	DRAG, STUD	25
1	1	455678-1	PLATE, STRIP GUIDE	24
				23
2	2	4-22281-1	SPRING, DRAG	22
				21
1	1	454177-1	DRAG, STOCK	20
1	1	1-458030-5	GUIDE, STRIP (REAR)	19
1	1	1-458031-5	GUIDE, STRIP (FRONT)	18
REF	REF	454178-1	GUIDE, FEED ROD	17
REF	REF	6-22284-4	SPRING, FEED RETURN	16
				15
				14
				13
				12
1	1	240644-1	PLATE, REAR SHEAR	11
2	2	1-240645-1	SPACER, SHEAR PLATE	10
1	1	240642-1	PLATE, FRONT SHEAR	9
1	1	1-461295-8	ANVIL	8
1	1	2-240651-8	BLADE, SLUG	7
				6
1	1	240641-3	SPACER, SLUG BLADE	5
1	1	238009-1	SPACER, BLOCK CRIMPER	4
1	1	456135-8	CRIMPER, INSULATION	3
1	1	455888-5	SPACER, CRIMPER	2
1	1	456411-9	CRIMPER, WIRE	1

1

1

1

1

QTY	REV	DESCRIPTION	ITEM NO
-2	-1	U/M	

QTY	REV	DESCRIPTION	ITEM NO
-2	-1	U/M	

THIS DRAWING IS A CONTROLLED DOCUMENT.

DWN: CERISMAN 090CT02  
CHK: -

Tyco Electronics Corporation  
Harrisburg, PA 17105-3608

APD: T.FELBIN 090CT02  
NAME: END FEED HDM APPLICATOR

PRODUCT SPEC: -  
APPLICATION SPEC: -  
SIZE: A1  
CAGE CODE: 00779  
DRAWING NO: 466794

RESTRICTED TO: -  
CUSTOMER DRAWING: -  
SCALE: -  
SHEET: 1 of 1  
REV: F