

1

2

3

4

5

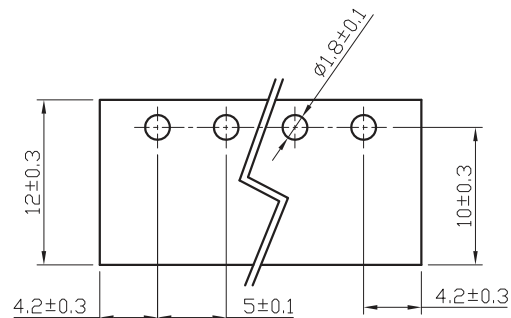

RECOMMENDED PCB LAYOUT - COMPONENT VIEW

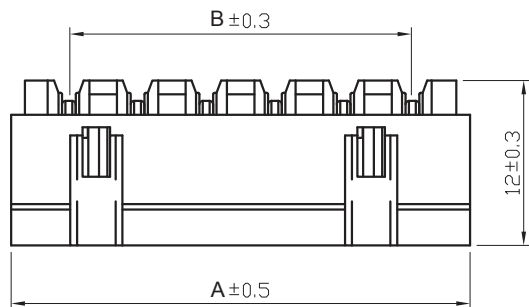
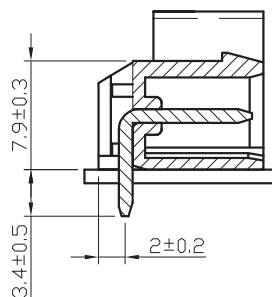
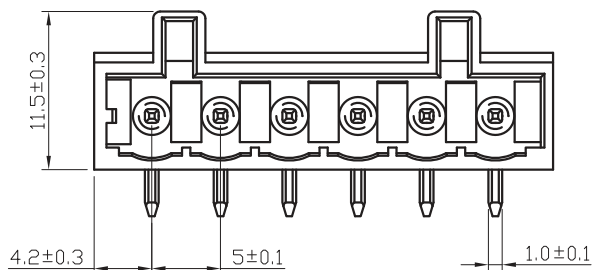

TECHNICAL CHARACTERISTICS

MATERIAL
 INSULATOR: PA 66
 FLAMABILITY RATING: UL94-V0
 COLOR: GREY
 CONTACT: BRASS
 CONTACT PLATING: TIN

ENVIRONMENTAL
 OPERATING TEMPERATURE: -40 UP TO 105°C
 COMPLIANCE: LEAD FREE AND ROHS

ELECTRICAL cULus
 CURRENT RATING: 16A
 WORKING VOLTAGE: 300VAC
 WITHSTANDING VOLTAGE: 2.0KV
 CONTACT RESISTANCE: 2000 MOhm

STANDARD
 RoHS CERTIFIED E315414

PITCH: 5.0 MM

SOLDERING
 JEDEC LEAD FREE WAVE PROCESS ONLY

PACKAGING
 BOX

DIMENSION
 DIM B = 5 x (NB POLES - 1)
 DIM A = 5 x (NB POLES - 1) + 8.4

RoHS Compliant

PROJECTION:



GENERAL TOLERANCE

.X = +/- 0.2

.XX = +/- 0.15



APPROVAL: RJ

UNIT: MM

SCALE:

SHEET: 1/2

DRAW: QL

DESCRIPTION: SERIE 370B - 5.00MM HORIZONTAL PCB HEADER WR-TBL

WERI PART NO: 691 370 710 0xxB

SIZE

A4

G			
F			
E			
D			
C			
B			
A	03-JUN-13	PDF	QL
REV	DATE	FILE	BY

1

2

3

4

5

Cautions and Warnings:

This electronic component is designed and developed with the intention for use in general electronics equipments.

Before incorporating the components into any equipments in the field such as aerospace, aviation, nuclear control, submarine, transportation, (automotive control, train control, ship control), transportation signal, disaster prevention, medical, public information network etc. where higher safety and reliability are especially required or if there is possibility of direct damage or injury to human body, Würth Elektronik must be asked for a written approval.



In addition, even electronic component in general electronic equipments, when used in electrical circuits that require high safety, reliability functions or performance, the sufficient reliability evaluation-check for the safety must be performed before by the user before usage.

A

B

C

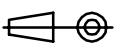
RoHS Compliant

G				PROJECTION: 	GENERAL TOLERANCE .X = +/- 0.2 .XX = +/- 0.15		
F							
E							
D							
C				APPROVAL: JC	UNIT: MM	DESCRIPTION: DISCLAIMER	SIZE A4
B					SCALE:		
A	10-SEP-14	PDF	QL		SHEET: 2/2	WERI PART NO: DISCLAIMER	
REV	DATE	FILE	BY		DRAW: QL		

D