

- NOTES:
1. MOUNTING: Mounts in a $\phi .281 \pm .002$ [$\phi 7.13\text{mm} \pm .05$] panel hole on .375 [9.5mm] centers. Panel thickness .031 [0.8mm] to .250 [6.35mm]. Panel hole should be deburred, but not chamfered.
 2. ASSEMBLY: Insert lens through panel hole, slide RNG 268 retainer on back of lens. PCB mounted LEDs slide into lens when the panel cover is closed or the PCB card is inserted into the case.
 3. MATERIAL: Polycarbonate, UL 94-V2
 4. U.S. & Foreign Pat. Issued & Pend.

REVISIONS				
ECN#	REV.	DESCRIPTION	DATE	INITIALS
	001	REVISED PER EC R111009AZ01	4-23-10	SMU

RETAINER
(ORDER SEPARATELY)

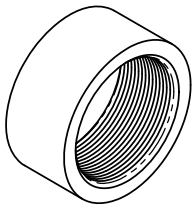

RNG 268

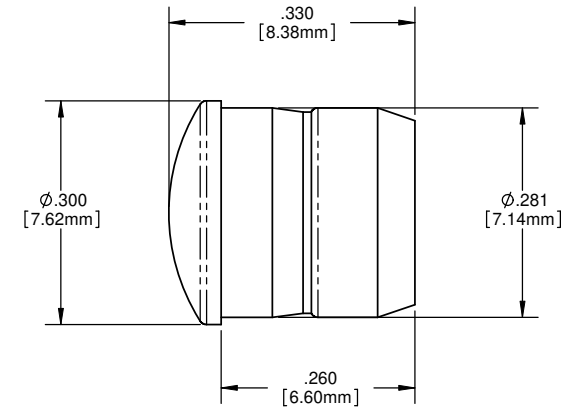
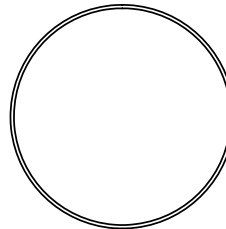

ORDERING CODE : CMC 321 XXX

MODEL

LENS COLOR	
RTP	RED TRANSPARENT
ATP	AMBER TRANSPARENT
GTP	GREEN TRANSPARENT
BTP	BLUE TRANSPARENT
YTP	YELLOW TRANSPARENT
CTP	CLEAR TRANSPARENT

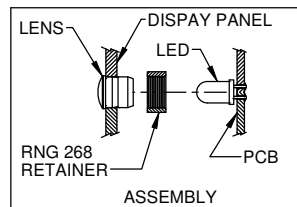

UNLESS OTHERWISE SPECIFIED
DIMENSIONS ARE IN INCHES:
ANGLES DECIMALS
 $\pm 1^\circ$.X $\pm .020$
XXX $\pm .010$
FINISH XXX $\pm .005$

BREAK ALL CORNERS AND SHARP
EDGES 90° MIN

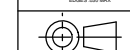

THIRD ANGLE PROJECTION

PROPRIETARY AND CONFIDENTIAL
THE INFORMATION CONTAINED IN THIS
DRAWING IS THE SOLE PROPERTY OF
VISUAL COMMUNICATIONS COMPANY, INC. AND
REPRODUCTION IN PART OR AS A WHOLE
WITHOUT THE WRITTEN CONSENT OF
VISUAL COMMUNICATIONS COMPANY, INC. IS
PROHIBITED.

MATERIAL	
POLYCARBONATE, UL 94-V2	
FINISH	
SEE NOTES	
APPROVAL	DATE
DRAWN: SMU	4-23-10
CHECKED: DZ	4-23-10
DO NOT SCALE DRAWING	

VISUAL COMMUNICATIONS COMPANY, INC. 190 Bosstick Boulevard, Suite 101 San Marcos, CA 92069 USA Phone (760) 560-1300 Fax (760) 560-1301 email vccsales@vccite.com		
TITLE: 5MM ROUND FRESNEL LOW PROFILE LENS		
SIZE	DWG. NO.	REV
B	CMC 321 XXX	001
SCALE: 1:1		SHEET 1 OF 1