

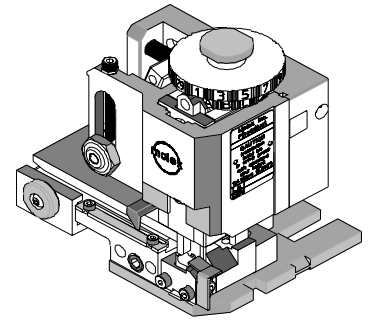

FineAdjust Applicator Specification Sheet Part No. 63867-2000



FEATURES

- Quick punch removal with the push of a button for fast and easy tooling change
- Applicator designed to industry standard mounting and shut height 135.80mm (5.346")
- Quick set-up time; plus the crimp height, track and feed adjustments can be set without removing the applicator from the press
- Fine adjustment allows users to achieve target with little effort by adjusting in increments of 0.15mm (.0006") for conductor crimp height and .063mm (.0025") for insulation height
- Independent adjustment rings allow users to quickly adjust the conductor or insulation crimp height without affecting each other
- Directly adapts to most automatic wire processing machines

SCOPE

Terminal Series No.	Wire Size		Insulation Diameter		Strip Length	
	AWG	mm ²	mm	In.	mm	In.
5194	18-24	0.80-0.20	1.30-3.00	.051-.118	3.00-3.50	.118-.138

DEFINITION OF TERMS

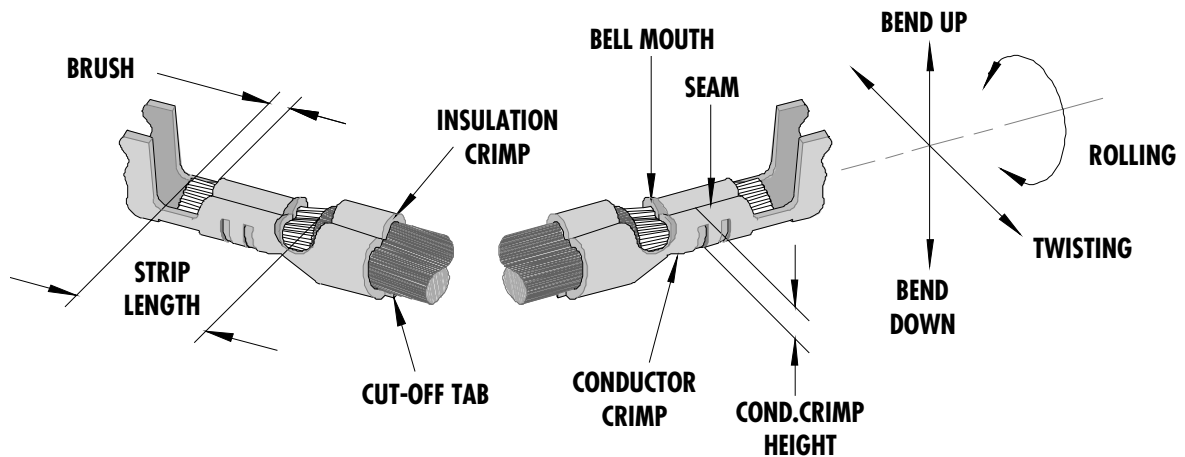

The above terminal drawing is a generic terminal representation. It is not an image of a terminal listed in the scope.

CRIMP SPECIFICATION

Terminal Series No.	Bell mouth		Cut-off Tab Max.		Conductor Brush	
	mm	In.	mm	In.	mm	In.
5194	0.20-0.70	.008-.028	0.40	.016	0.00-1.00	.000-.039

Terminal Series No.	Bend up	Bend down	Twist	Roll	Punch Width mm (Ref)				Seam Seam shall not be open and no wire allowed out of the crimping area
	Degree		Degree		Conductor		Insulation		
					mm	In	mm	In	
5194	6	0	3	8	1.60	.063	2.80	.110	

After crimping, the conductor profile should measure the following.

Terminal Series No.	Wire Size		Conductor Crimp Height		Pull Force Min.	
	AWG	mm ²	mm	In.	N	Lb.
	5194	18	0.80	1.10-1.20	.043-.047	88.1
5194	20	0.50	1.07-1.17	.042-.046	58.7	13.20
5194	22	0.35	0.96-1.06	.038-.042	39.1	8.80
5194	24	0.20	0.90-1.00	.035-.039	29.4	6.60

Pull Force should be measured with no influence from the insulation crimp.

The above specifications are guidelines to an optimum crimp.

PARTS LIST

Item	Order No	Engineering No.	Description	Quantity
	63867-2000	63867-2000	FineAdjust Applicator (Fig. 1)	REF
1	63444-1605	63444-1605	Conductor Punch	1 Y
2	63445-1641	63445-1641	Conductor Anvil	1 Y
3	63446-2827	63446-2827	Insulation Punch	1 Y
4	63445-2835	63445-2835	Insulation Anvil	1 Y
5	63443-0002	63443-0002	Cut-Off Plunger	1 Y
6	63443-0012	63443-0012	Front Plunger Retainer	1 Y
7	11-24-1067	4996-4	Cut-Off Plunger Spring	1
8	11-40-4039	8302-5	Front Plunger Striker	1
9	63443-0021	63443-0021	Lower Tooling Key	1
10	63443-6003	63443-6003	Rear Cover	1
11	11-18-4083	60707-8	Front Cover	1
12	63443-2425	63443-2425	Anvil Mount	1
13	63443-4005	63443-4005	Wire Stop	1
14	63443-0009	63443-0009	Scrap Chute	1
15	63801-3100	63801-3100	Wide Track FineAdjust	1
16	N/A	N/A	M3 by 6Lg. SHCS	2**
17	N/A	N/A	M4 by 6Lg. SHCS	1**
18	N/A	N/A	M4 by 12Lg. BHCS	2**
19	N/A	N/A	M4 by 16Lg. SHCS	1**
20	N/A	N/A	M4 by 20Lg. SHCS	1**
21	N/A	N/A	M4 by 50Lg. SHCS	1**
22	N/A	N/A	3MM by 6Lg. Roll Pin	1**
23	N/A	N/A	#10-32 by 1/4"Lg. BHCS	1**
	63867-2070	63867-2070	Tool Kit (All Y Items)	REF

** The following purchased parts are available from an Industrial supply company such as MSC (1-800-645-7270).

Assembly Drawing

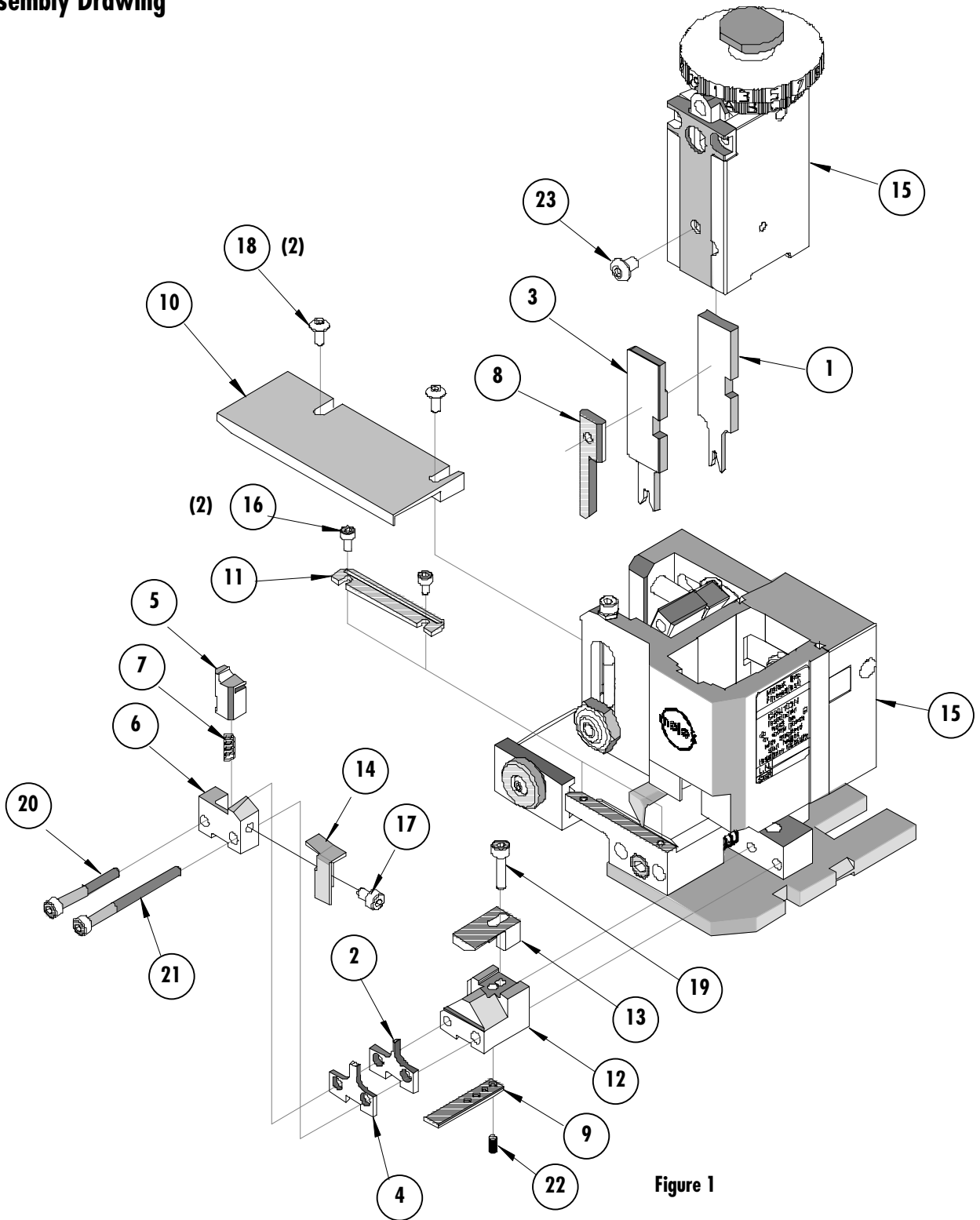

Figure 1

NOTES

1. Molex recommends an extra perishable tooling kit be maintained at your facility.
2. Verify tooling alignment by manually cycling the press and Applicator before crimping under power. Check that all screws are tight.
3. Slugs, Terminals, Dirt and Oil should be kept clear of work area.
4. Wear safety glasses at all times.
5. For recommended maintenance refer to the FineAdjust Manual.

CAUTION: This applicator should only be used in a press with a shut height of 135.8 mm (5.346"). Tooling damage could result at a lower setting.

CAUTION: To prevent injury never operate this Applicator without the guards supplied with the press or wire-processing machine in place. Reference the press or wire processing manufacturer's instruction manual.

CAUTION: Molex crimp specifications are valid only when used with Molex terminals, applicators and tooling.

Molex Application Tooling Group

1150 E. Diehl Road
Naperville, IL 60563
Tel: (630) 969-4550
Fax: (630) 505-0049

Visit our Web site at <http://www.molex.com>