

Data Sheet	SMS-2008MS-R
------------	--------------

Features:

- Pick-and-place, reflow capable speaker with good output
- Great frequency response in a small package
- Grill is integrated into the housing for speaker protection

Speaker Specifications

Parameters	Values	Units
Rated Input Power	0.8	Watts
Max Input Power	1.0	Watts
Impedance	8±15%	Ohms
Sensitivity @ 0.1W/0.1M (Avg 1.0, 1.6, 2.0, 3.2 kHz)	90±3	dB
Resonant Frequency	850±20%	Hz
Frequency Range <i>(based on -10 dB limits on frequency response graph)</i>	550 ~ 20,000	Hz
Frame Material	LCP	-
Magnet Material	SmCo	-
Weight	1.5	Grams
Acceptable Soldering Methods	Hand Solder, Reflow Solder	See below for soldering information
Environmental Compliances	RoHS	-
Polarity	Diaphragm moves outward when positive voltage is applied to positive terminal	-
Storage Temperature	-40 ~ +105	°C
Operating Temperature	-40 ~ +105	°C

Measurement Method

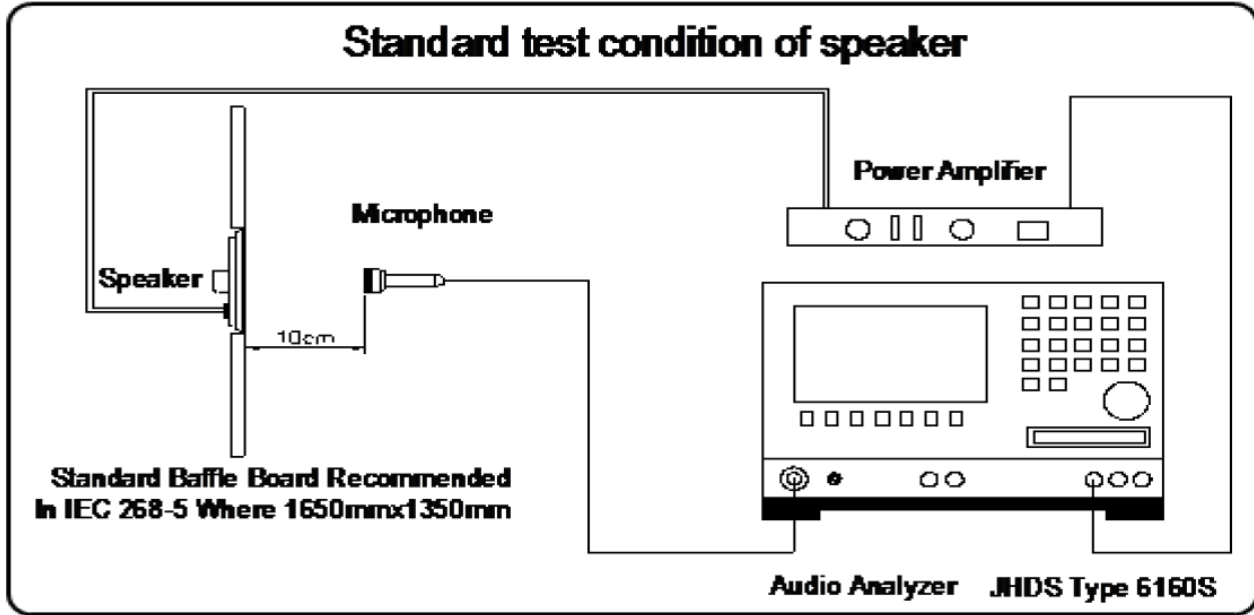

Typical Frequency Response (0.89V signal applied)

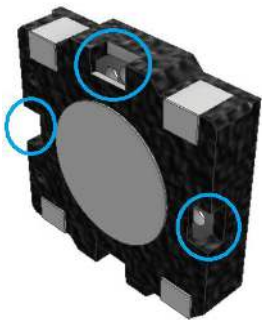

For best frequency response results, fill in these vent holes after reflow or hand soldering to prevent potential cancelation.

Recommended Soldering Procedure

a) Recommendable reflow soldering condition is as follows
 (Reflow soldering is twice)

Note: It is requested that reflow soldering should be executed after heat of product goes down to normal.

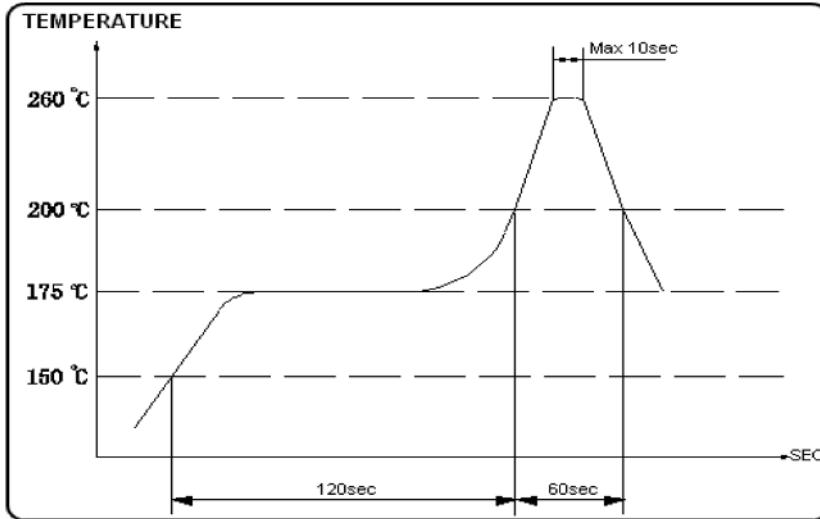

Heat resistant line (Used when heat resistant reliability test is performed)

b) Manual soldering

Manual soldering temperature 350° C within 5 sec.

Reliability Testing

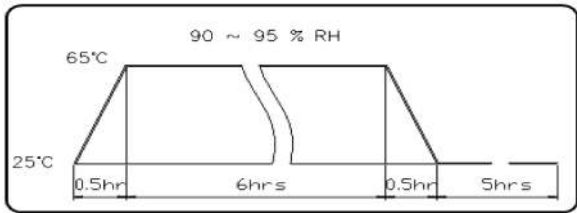
Type of Test	Test Specifications
High Temperature Test	96 hours at +85°C allow speaker to rest at room temperature for 3 hours before testing
Low Temperature Test	96 hours at -40°C allow speaker to rest at room temperature for 3 hours before testing
Humidity Test	96 hours at +40°C with relative humidity at 92-95% allow speaker to rest at room temperature for 3 hours before testing
Temperature Cycle Testing	The part shall be subjected 5 cycles. One cycle shall be 12 hours and consist of; 
Vibration Test	10~55~10 Hz sine-sweep 15 min. at 5G constant. X, Y, Z 6 directions, 1 time for a total of 6 cycles.
Drop Test	Free drop from 100cm height onto concrete floor, X, Y, Z 6 directions, 1 time for a total of 6 cycles
Load Test	Apply white noise at the rated power for 96 hours

Call out how pass/fail conditions are determined after the reliability testing is complete

Dimensions

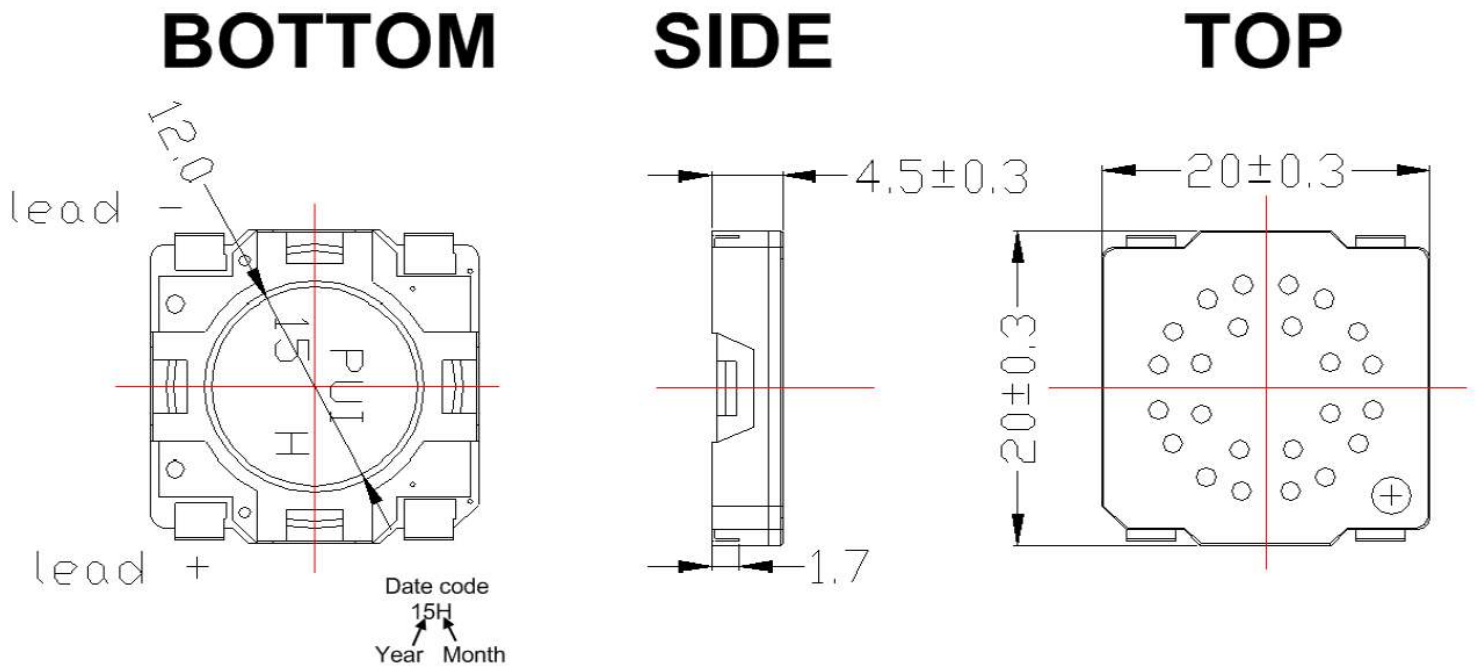

Suggested Land Pattern*

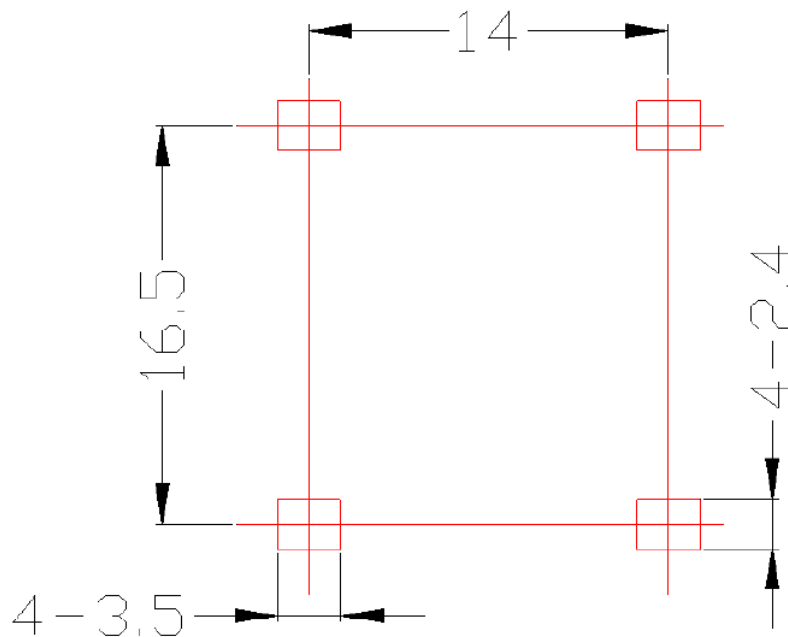

*This land pattern is advisory only and its use or adaptation is entirely voluntary. PUI Audio disclaims all liability of any kind associated with the use, application, or adaptation of this land pattern.

Packaging

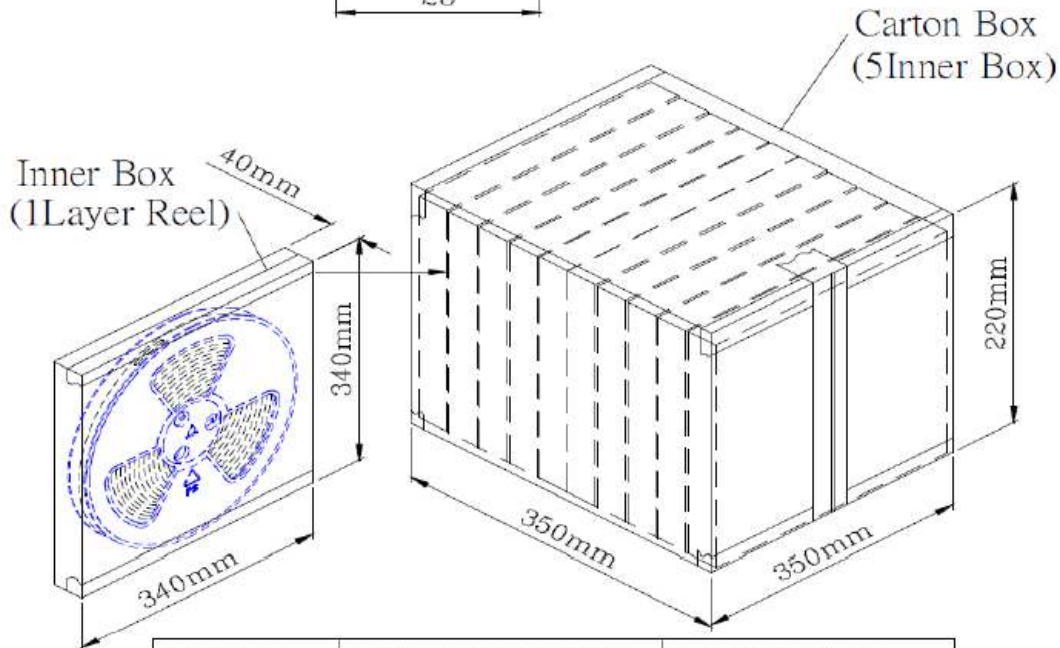
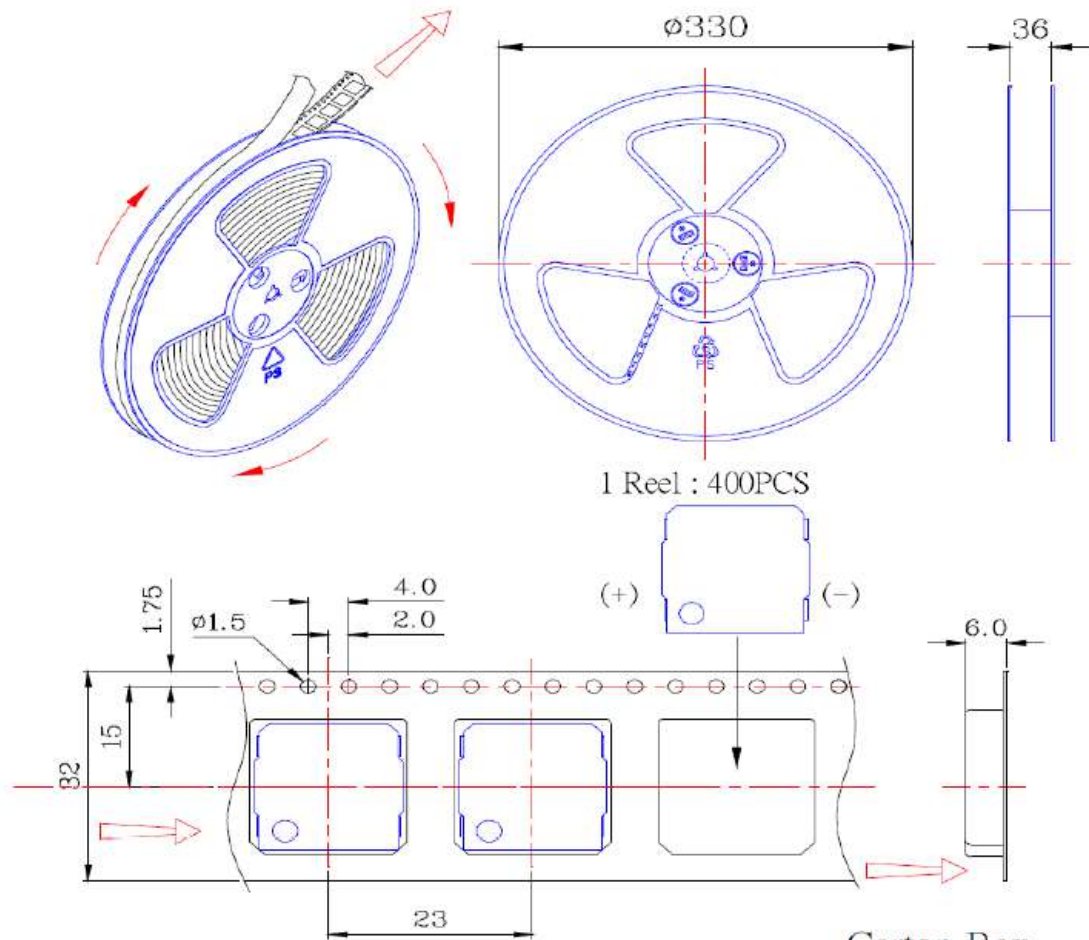

Inner Box	340mmx340mmx40mm	1x400PCS=400PCS
Carton Box	350mmx350mmx220mm	5x400PCS=2,000PCS

Specifications Revisions

Revision	Description	Date
-	Released from Engineering	8/25/2015
A	Revised Operating & Storage Temperature range	5/14/2020

Note:

1. Unless otherwise specified:
 - A. All dimensions are in millimeters.
 - B. Default tolerances are $\pm 0.5\text{mm}$ and angles are $\pm 3^\circ$.
2. Specifications subject to change or withdrawal without notice.