

DESCRIPTION

The H11F series consists of a Gallium-Aluminum-Arsenide IRED emitting diode coupled to a symmetrical bilateral silicon photo-detector. The detector is electrically isolated from the input and performs like an ideal isolated FET designed for distortion-free control of low level AC and DC analog signals. The H11F series devices are mounted in dual in-line packages.

FEATURES

As a remote variable resistor

- $\leq 100\Omega$ to $\geq 300\text{ M}\Omega$
- $\geq 99.9\%$ linearity
- $\leq 15\text{ pF}$ shunt capacitance
- $\geq 100\text{ G}\Omega$ I/O isolation resistance

As an analog switch

- Extremely low offset voltage
- $60\text{ V}_{\text{pk-pk}}$ signal capability
- No charge injection or latch-up
- $t_{\text{on}}, t_{\text{off}} \leq 15\ \mu\text{S}$
- UL recognized (File #E90700)
- VDE recognized (File #E94766)
 - Ordering option '300' (e.g. H11F1.300)

APPLICATIONS

As a variable resistor –

- Isolated variable attenuator
- Automatic gain control
- Active filter fine tuning/band switching

As an analog switch –

- Isolated sample and hold circuit
- Multiplexed, optically isolated A/D conversion

H11F1 H11F2 H11F3

Absolute Maximum Ratings ($T_A = 25^\circ\text{C}$ unless otherwise specified)				
Parameter	Symbol	Device	Value	Units
TOTAL DEVICE				
Storage Temperature	T_{STG}	All	-55 to +150	$^\circ\text{C}$
Operating Temperature	T_{OPR}	All	-55 to +100	$^\circ\text{C}$
Lead Solder Temperature	T_{SOL}	All	260 for 10 sec	$^\circ\text{C}$
EMITTER				
Continuous Forward Current	I_F	All	60	mA
Reverse Voltage	V_R	All	5	V
Forward Current - Peak (10 μs pulse, 1% duty cycle)	$I_{F(\text{pk})}$	All	1	A
LED Power Dissipation 25°C Ambient Derate Linearly From 25°C	P_D	All	100	mW
			1.33	mW/ $^\circ\text{C}$
DETECTOR				
Detector Power Dissipation @ 25°C Derate linearly from 25°C	P_D	All	300	mW
			4.0	mW/ $^\circ\text{C}$
Breakdown Voltage (either polarity)	BV_{4-6}	H11F1, H11F2	± 30	V
		H11F3	± 15	V
Continuous Detector Current (either polarity)	I_{4-6}	All	± 100	mA

ELECTRICAL CHARACTERISTICS ($T_A = 25^\circ\text{C}$ Unless otherwise specified.)

INDIVIDUAL COMPONENT CHARACTERISTICS

Parameter	Test Conditions	Symbol	Device	Min	Typ*	Max	Unit
EMITTER							
Input Forward Voltage	$I_F = 16 \text{ mA}$	V_F	All		1.3	1.75	V
Reverse Leakage Current	$V_R = 5 \text{ V}$	I_R	All			10	μA
Capacitance	$V = 0 \text{ V}, f = 1.0 \text{ MHz}$	C_J	All		50		pF
OUTPUT DETECTOR							
Breakdown Voltage Either Polarity	$I_{4-6} = 10\mu\text{A}, I_F = 0$	BV_{4-6}	H11F1, H11F2	30			V
			H11F3	15			
Off-State Dark Current	$V_{4-6} = 15 \text{ V}, I_F = 0$	I_{4-6}	All			50	nA
	$V_{4-6} = 15 \text{ V}, I_F = 0, T_A = 100^\circ\text{C}$		All			50	μA
Off-State Resistance	$V_{4-6} = 15 \text{ V}, I_F = 0$	R_{4-6}	All	300			M Ω
Capacitance	$V_{4-6} = 15 \text{ V}, I_F = 0, f = 1\text{MHz}$	C_{4-6}	All			15	pF

H11F1 H11F2 H11F3

ISOLATION CHARACTERISTICS

Parameter	Test Conditions	Symbol	Min	Typ*	Max	Units
Input-Output Isolation Voltage	f = 60Hz, t = 1 min.	V_{ISO}	5300			Vac (rms)
Isolation Resistance	$V_{I-O} = 500$ VDC	R_{ISO}	10^{11}			Ω
Isolation Capacitance	$V_{I-O} = 0$, f = 1.0 MHz	C_{ISO}			2	pF

TRANSFER CHARACTERISTICS (T_A = 25°C Unless otherwise specified.)

DC Characteristics	Test Conditions	Symbol	Device	Min	Typ*	Max	Units
On-State Resistance	$I_F = 16$ mA, $I_{4-6} = 100$ μ A	R_{4-6}	H11F1			200	Ω
			H11F2			330	
			H11F3			470	
On-State Resistance	$I_F = 16$ mA, $I_{6-4} = 100$ μ A	R_{6-4}	H11F1			200	Ω
			H11F2			330	
			H11F3			470	
Resistance, non-linearity and assymetry	$I_F = 16$ mA, $I_{4-6} = 25$ μ A RMS, f = 1kHz		All			0.1	%
AC Characteristics	Test Conditions	Symbol	Device	Min	Typ*	Max	Units
Turn-On Time	$R_L = 50\Omega$, $I_F = 16$ mA, $V_{4-6} = 5$ V	t_{on}	All			25	μ S
Turn-Off Time	$R_L = 50\Omega$, $I_F = 16$ mA, $V_{4-6} = 5$ V	t_{off}	All			25	μ S

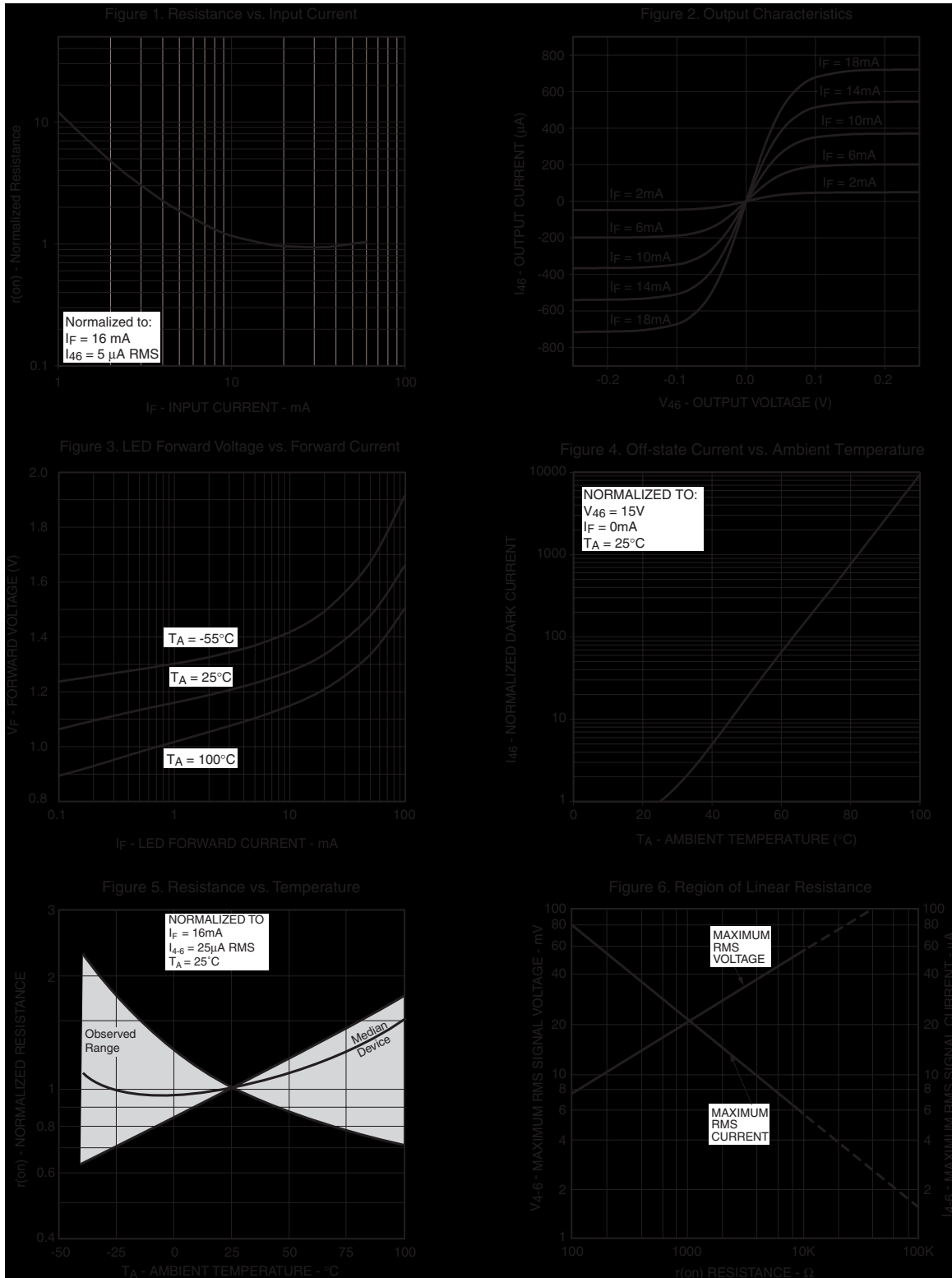

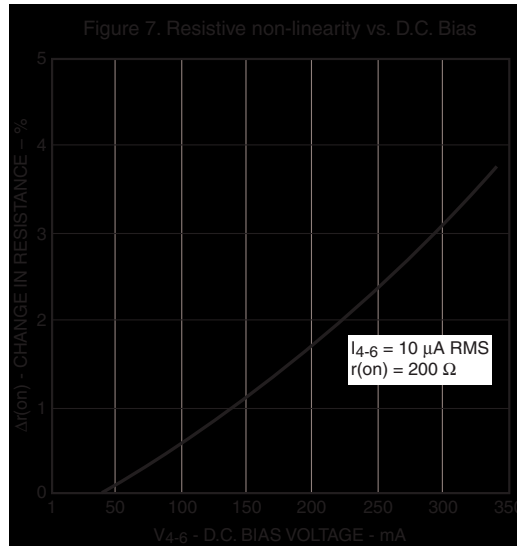

TYPICAL APPLICATIONS

AS A VARIABLE RESISTOR

ISOLATED VARIABLE ATTENUATORS

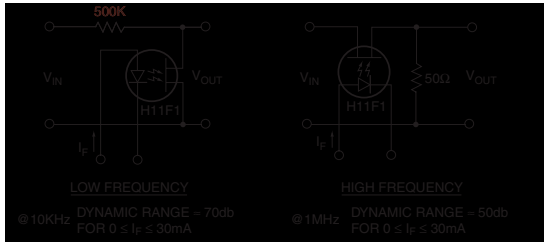

Distortion free attenuation of low level A.C. signals is accomplished by varying the IRED current, I_F . Note the wide dynamic range and absence of coupling capacitors; D.C. level shifting or parasitic feedback to the controlling function.

AS AN ANALOG SIGNAL SWITCH

ISOLATED SAMPLE AND HOLD CIRCUIT

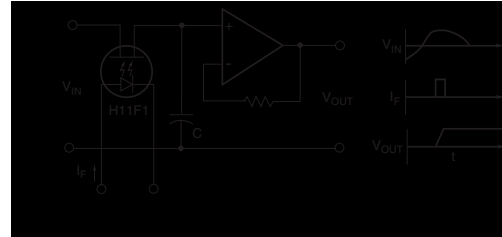

Accuracy and range are improved over conventional FET switches because the H11F has no charge injection from the control signal. The H11F also provides switching of either polarity input signal up to 30V magnitude.

AUTOMATIC GAIN CONTROL

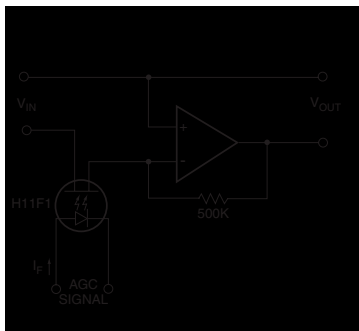

This simple circuit provides over 70db of stable gain control for an AGC signal range of from 0 to 30mA. This basic circuit can be used to provide programmable fade and attack for electronic music.

MULTIPLEXED, OPTICALLY-ISOLATED A/D CONVERSION

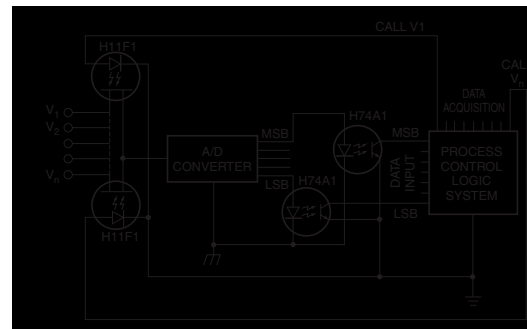

The optical isolation, linearity and low offset voltage of the H11F allows the remote multiplexing of low level analog signals from such transducers as thermocouples, Hall effect devices, strain gauges, etc. to a single A/D converter.

ACTIVE FILTER FINE TUNING/BAND SWITCHING

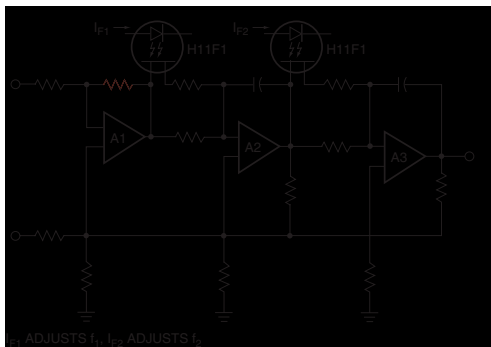

The linearity of resistance and the low offset voltage of the H11F allows the remote tuning or band-switching of active filters without switching glitches or distortion. This schematic illustrates the concept, with current to the H11F1 IRED's controlling the filter's transfer characteristic.

TEST EQUIPMENT - KELVIN CONTACT POLARITY

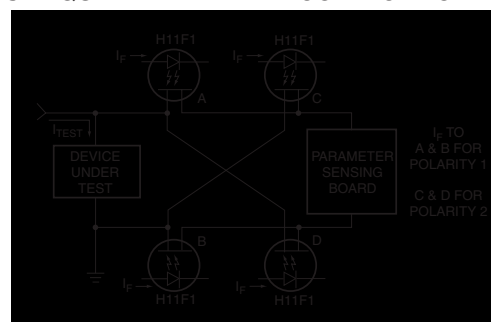

In many test equipment designs the auto polarity function uses reed relay contacts to switch the Kelvin Contact polarity. These reeds are normally one of the highest maintenance cost items due to sticking contacts and mechanical problems. The totally solid-State H11F eliminates these troubles while providing faster switching.

PHOTO FET OPTOCOUPPLERS

H11F1 H11F2 H11F3

Package Dimensions (Through Hole)

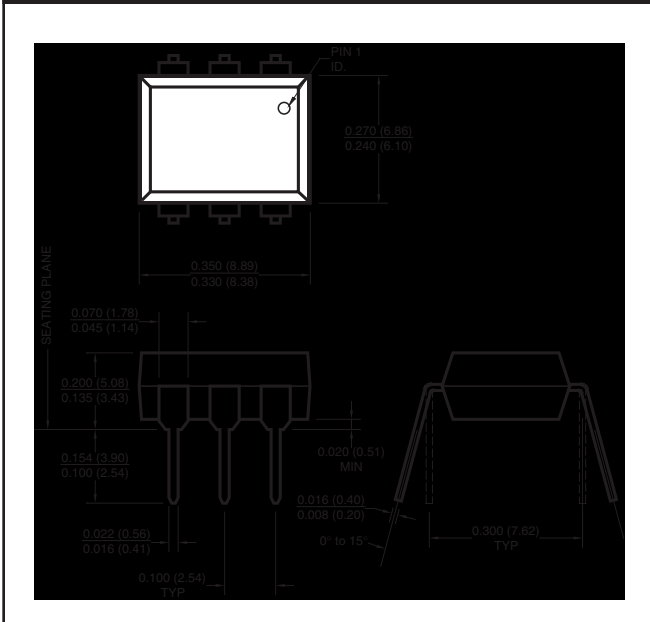

Package Dimensions (Surface Mount)



Package Dimensions (0.4" Lead Spacing)

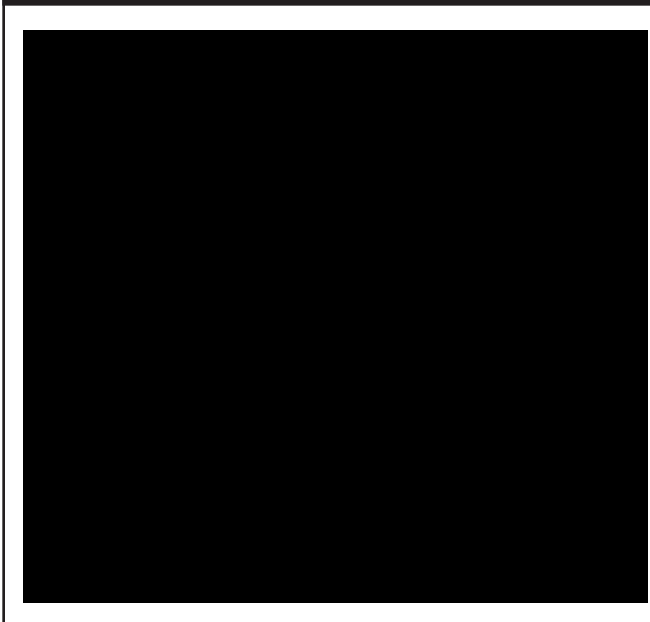

Recommended Pad Layout for Surface Mount Leadform

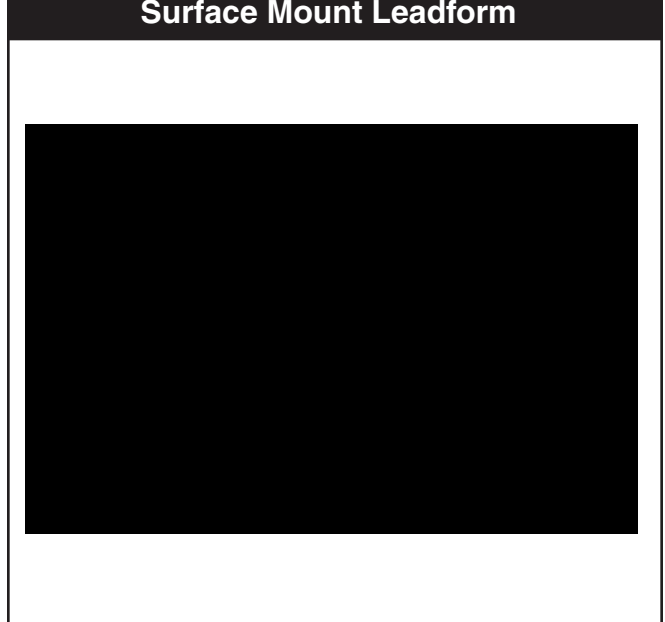

NOTE

All dimensions are in inches (millimeters)

PHOTO FET OPTOCOUPPLERS

H11F1 H11F2 H11F3

ORDERING INFORMATION

Option	Order Entry Identifier	Description
S	.S	Surface Mount Lead Bend
SD	.SD	Surface Mount; Tape and Reel
W	.W	0.4" Lead Spacing
300	.300	VDE 0884
300W	.300W	VDE 0884, 0.4" Lead Spacing
3S	.3S	VDE 0884, Surface Mount
3SD	.3SD	VDE 0884, Surface Mount, Tape and Reel

MARKING INFORMATION

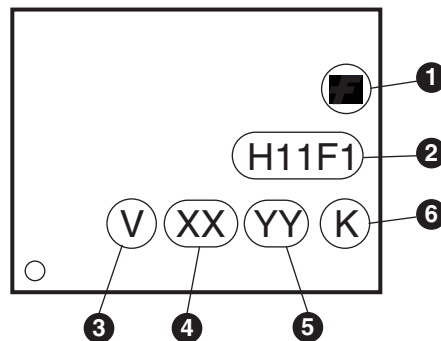

Definitions	
1	Fairchild logo
2	Device number
3	VDE mark (Note: Only appears on parts ordered with VDE option – See order entry table)
4	Two digit year code, e.g., '03'
5	Two digit work week ranging from '01' to '53'
6	Assembly package code

Carrier Tape Specifications



NOTE

All dimensions are in inches (millimeters)

Tape and reel quantity is 1,000 units per reel

Reflow Profile (Black Package, No Suffix)

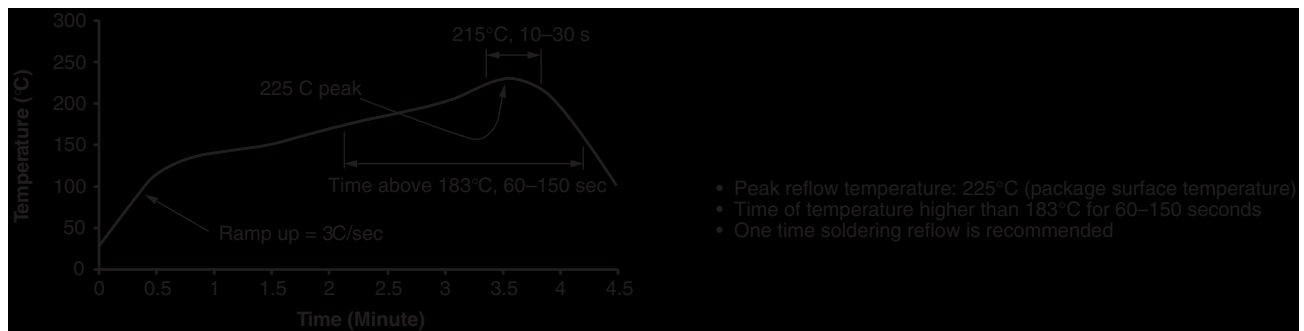

DISCLAIMER

FAIRCHILD SEMICONDUCTOR RESERVES THE RIGHT TO MAKE CHANGES WITHOUT FURTHER NOTICE TO ANY PRODUCTS HEREIN TO IMPROVE RELIABILITY, FUNCTION OR DESIGN. FAIRCHILD DOES NOT ASSUME ANY LIABILITY ARISING OUT OF THE APPLICATION OR USE OF ANY PRODUCT OR CIRCUIT DESCRIBED HEREIN; NEITHER DOES IT CONVEY ANY LICENSE UNDER ITS PATENT RIGHTS, NOR THE RIGHTS OF OTHERS.

LIFE SUPPORT POLICY

FAIRCHILD'S PRODUCTS ARE NOT AUTHORIZED FOR USE AS CRITICAL COMPONENTS IN LIFE SUPPORT DEVICES OR SYSTEMS WITHOUT THE EXPRESS WRITTEN APPROVAL OF THE PRESIDENT OF FAIRCHILD SEMICONDUCTOR CORPORATION. As used herein:

1. Life support devices or systems are devices or systems which, (a) are intended for surgical implant into the body, or (b) support or sustain life, and (c) whose failure to perform when properly used in accordance with instructions for use provided in the labeling, can be reasonably expected to result in a significant injury of the user.
2. A critical component in any component of a life support device or system whose failure to perform can be reasonably expected to cause the failure of the life support device or system, or to affect its safety or effectiveness.