

LOC		DIST		REVISIONS			
P	LTN	DESCRIPTION	DATE	DWN	APVD		
B1		REVISED PER ECO-09-021480	08OCT2009	CR	DG		
B2		REVISED PER ECO-10-016367	02AUG2010	JY	SY		
B3		REVISED PER ECN-22-179890	17OCT2022	SK	DZ		

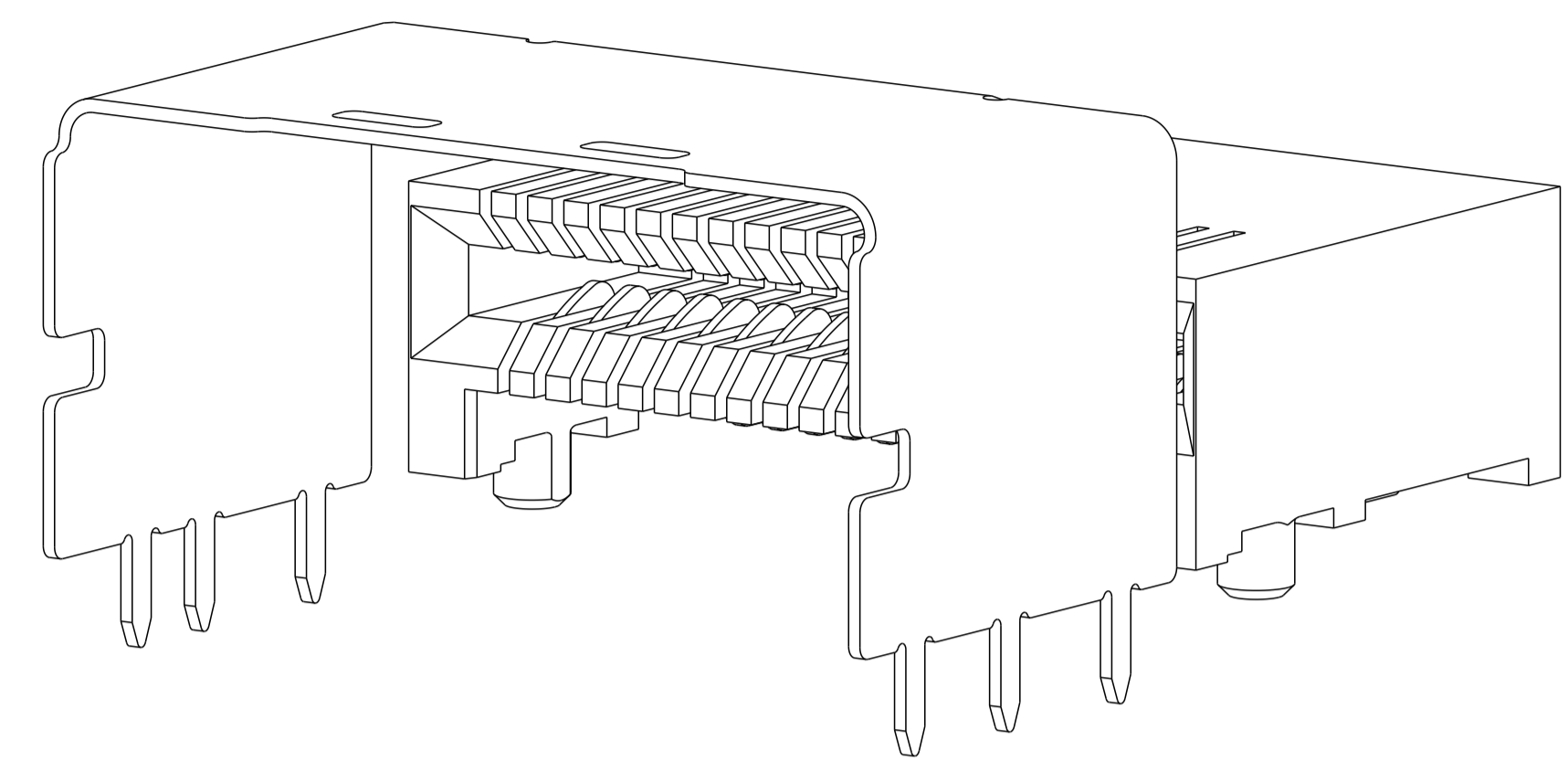

1888861-2 AND 1888861-9
 SHOWN WITHOUT PICK AND PLACE DEVICE

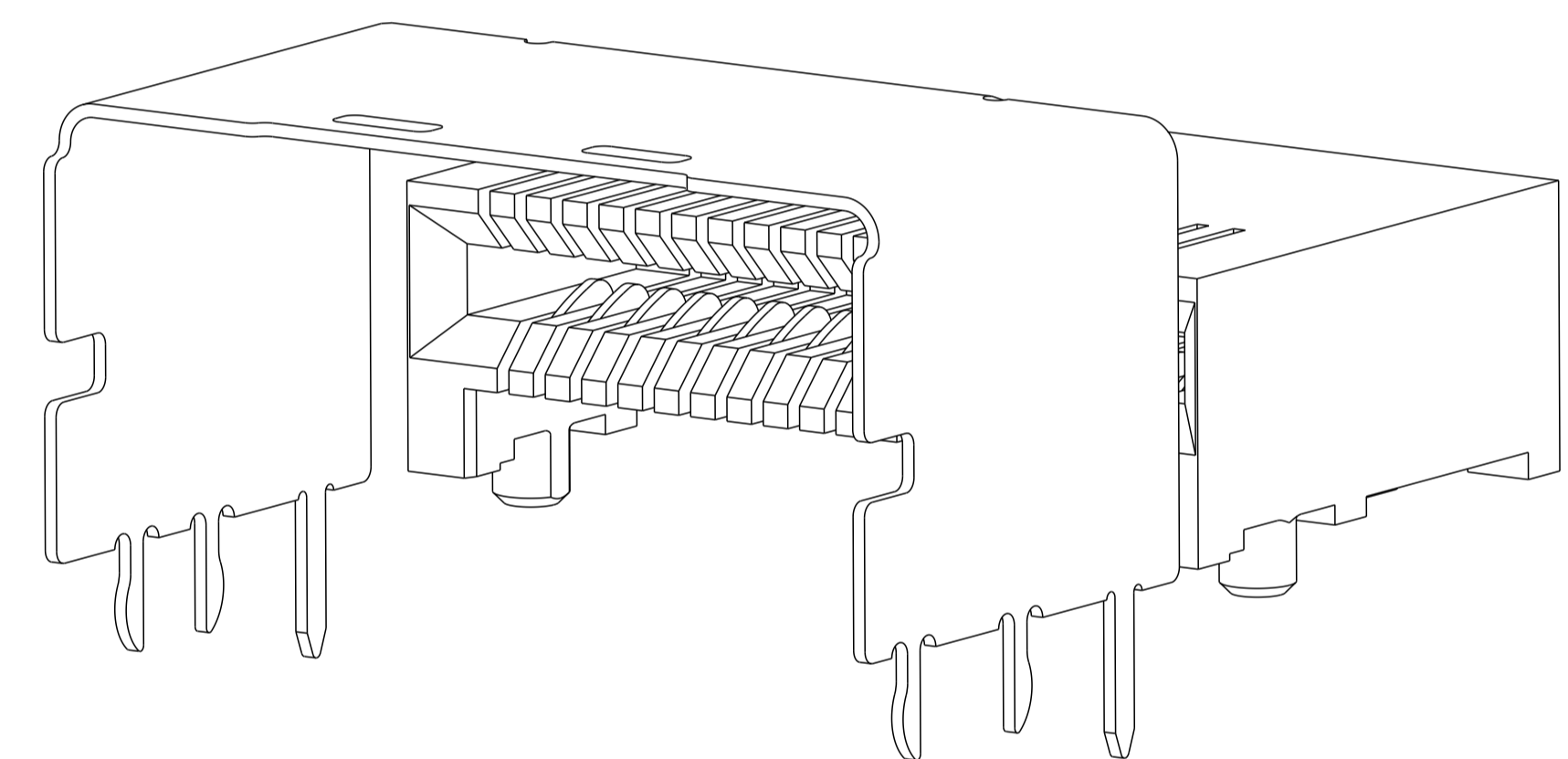

1888861-4 AND 1-1888861-0
 SHOWN WITHOUT PICK AND PLACE DEVICE

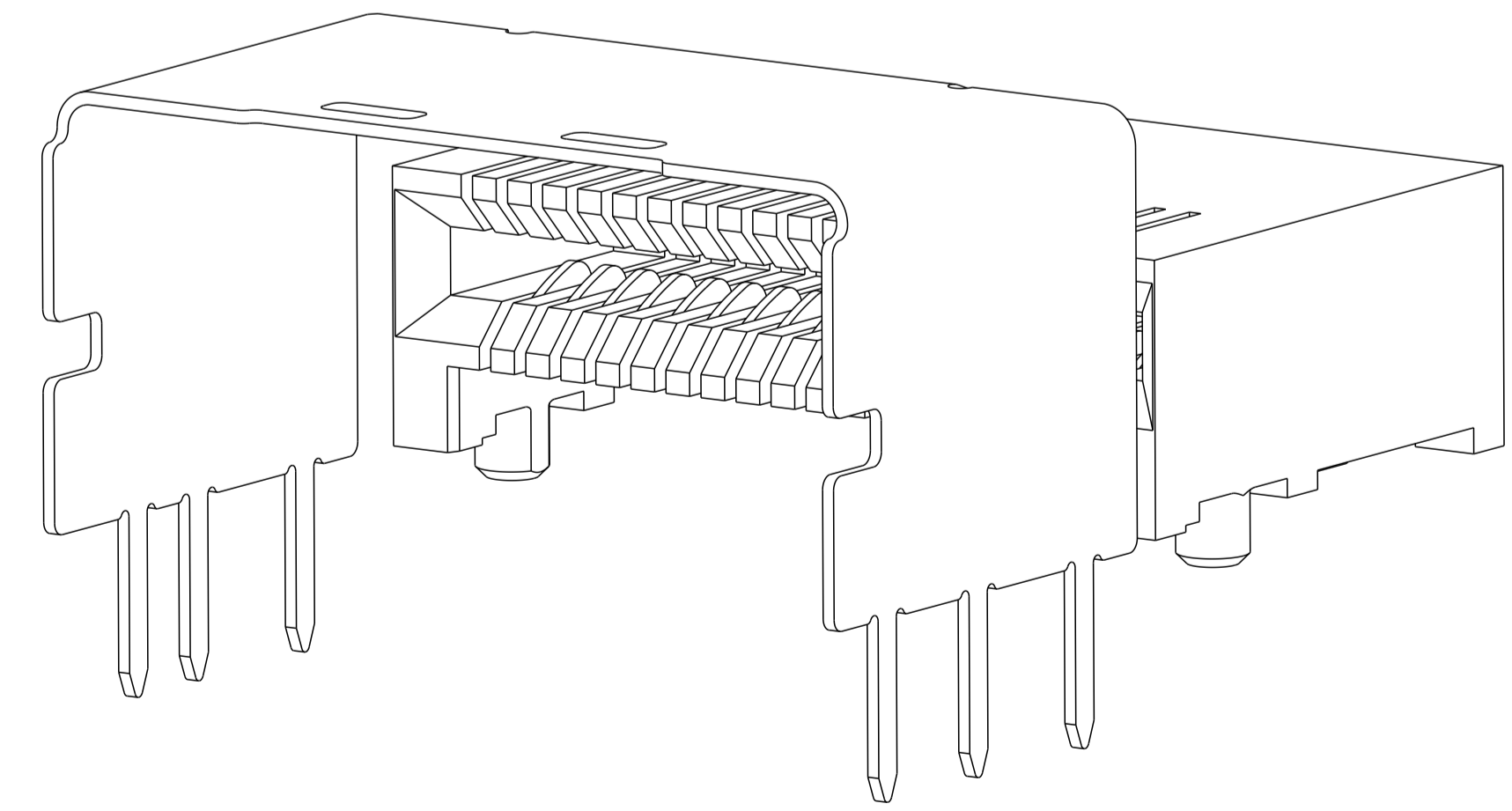

1888861-8 AND 1-1888861-2
 SHOWN WITHOUT PICK AND PLACE DEVICE

△ MATERIAL: LCP, BLACK.

△ MATERIAL: PHOSPHOR BRONZE PER ASTM B 103.

△ FINISH: 0.76um MIN GOLD PLATE PER ASTM B 488, APPLIES TO INTERFACE AREA AND 2.03um MIN TIN PLATE SOLDER TAILS, ALL OVER 3.81um MIN NICKEL PLATE PER QQ-N-290.

△ MATERIAL: NICKEL-SILVER PER ASTM B 122.

△ DATUM AND BASIC DIMENSION ESTABLISHED BY CUSTOMER.

6. REFER TO CUSTOMER DRAWING 1761987 FOR CONNECTOR DETAILS.

7. PACKAGED IN TAPE AND REEL PER EIA-481.

△ FINISH: 0.38um MIN GOLD PLATE PER ASTM B 488, APPLIES TO INTERFACE AREA AND 2.03um MIN TIN PLATE SOLDER TAILS, ALL OVER 3.81um MIN NICKEL PLATE PER QQ-N-290.

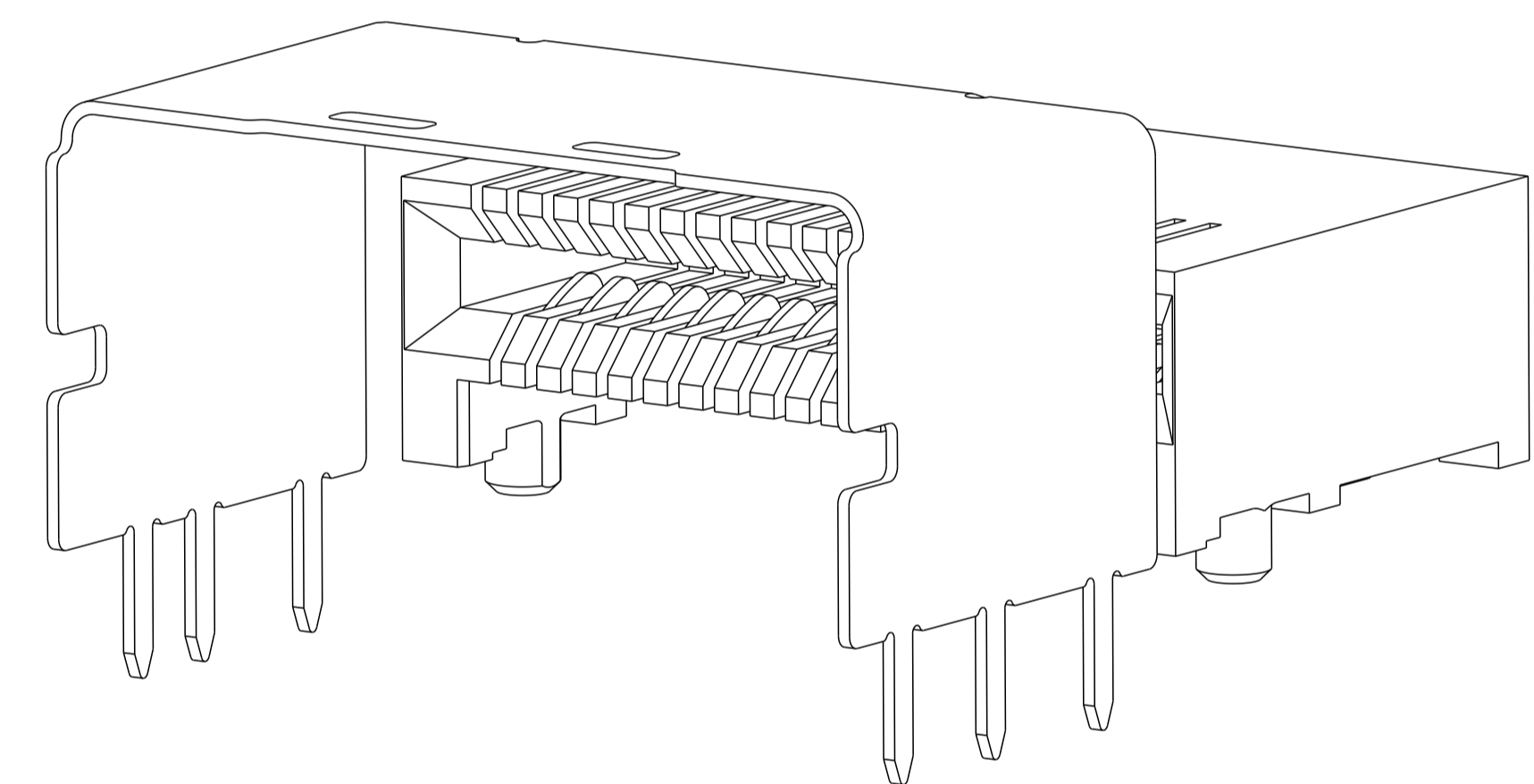

1888861-6 AND 1-1888861-1
 SHOWN WITHOUT PICK AND PLACE DEVICE

1-1888861-2 IS DISCONTINUED

FINISH	REMARKS	G	E	D	C	B	A	POSN	PART NUMBER
△	THRU HOLE	3.5	17.8	16	16	36	18.05	36	1-1888861-2
		2.8	17.8	16	16	36	18.05	36	1-1888861-1
	PRESS FIT	-	17.8	16	16	36	18.05	36	1-1888861-0
△	THRU HOLE	2	17.8	16	16	36	18.05	36	1888861-9
	THRU HOLE	3.5	17.8	16	16	36	18.05	36	1888861-8
	PRESS FIT	-	17.8	16	16	36	18.05	36	1888861-4
	THRU HOLE	2	17.8	16	16	36	18.05	36	1888861-2

DIMENSIONS: mm 		TOLERANCES UNLESS OTHERWISE SPECIFIED: 0 PLC ± 1 PLC ± 2 PLC ± 3 PLC ± 4 PLC ± ANGLES ± FINISH ±		DWN B. MCMASTER 21FEB07 CHK D. GORENC 21FEB07 APVD D. GORENC 21FEB07		Tyco Electronics Harrisburg, PA 17105-3608	
MATERIAL: SEE NOTES		FINISH: SEE TABLE		WEIGHT: - CUSTOMER DRAWING		NAME: EVERCLEAR Mini-SAS RIGHT ANGLE, INTERNAL RECEPTACLE ASSEMBLY, WITH UNKEYED SHELL PRODUCT SPEC: 108-2234 APPLICATION SPEC: - SIZE: A 00779 C=1888861 SCALE: 8:1 SHEET 1 OF 3 REV B3	

LOC	DIST	REVISIONS					
GP	00	P	LTN	DESCRIPTION	DATE	DWN	APVD
		-		SEE SHEET 1			

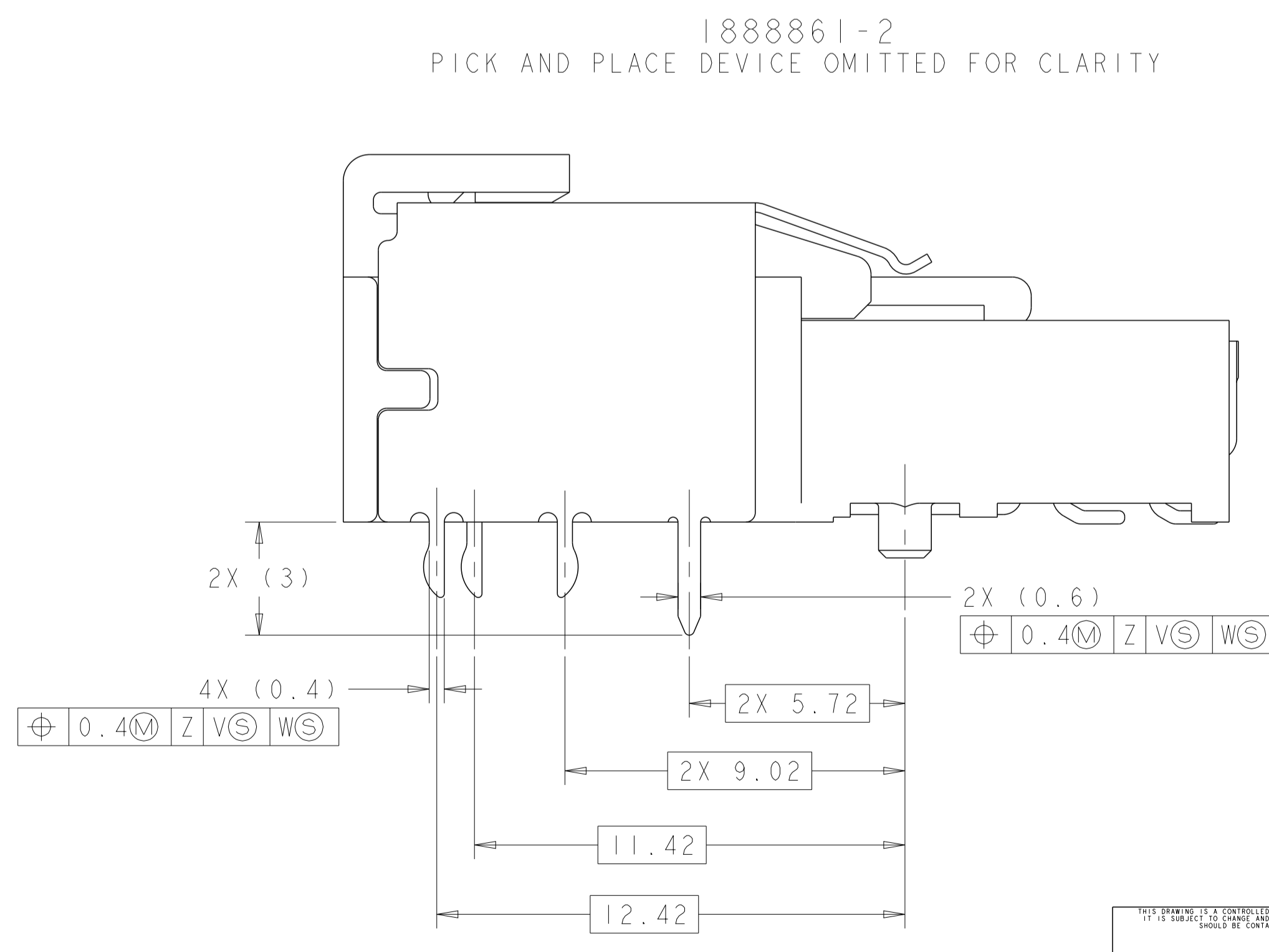
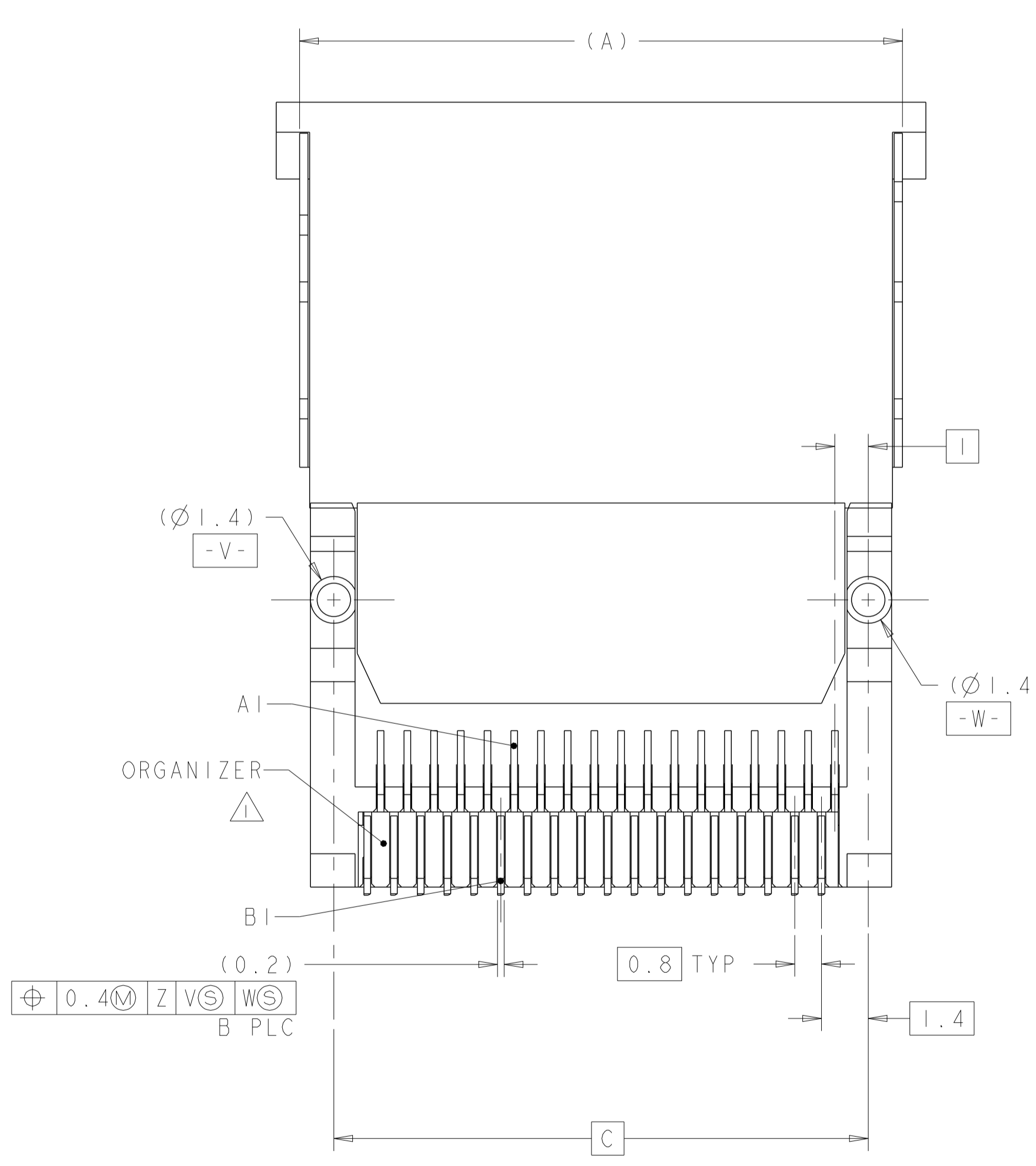
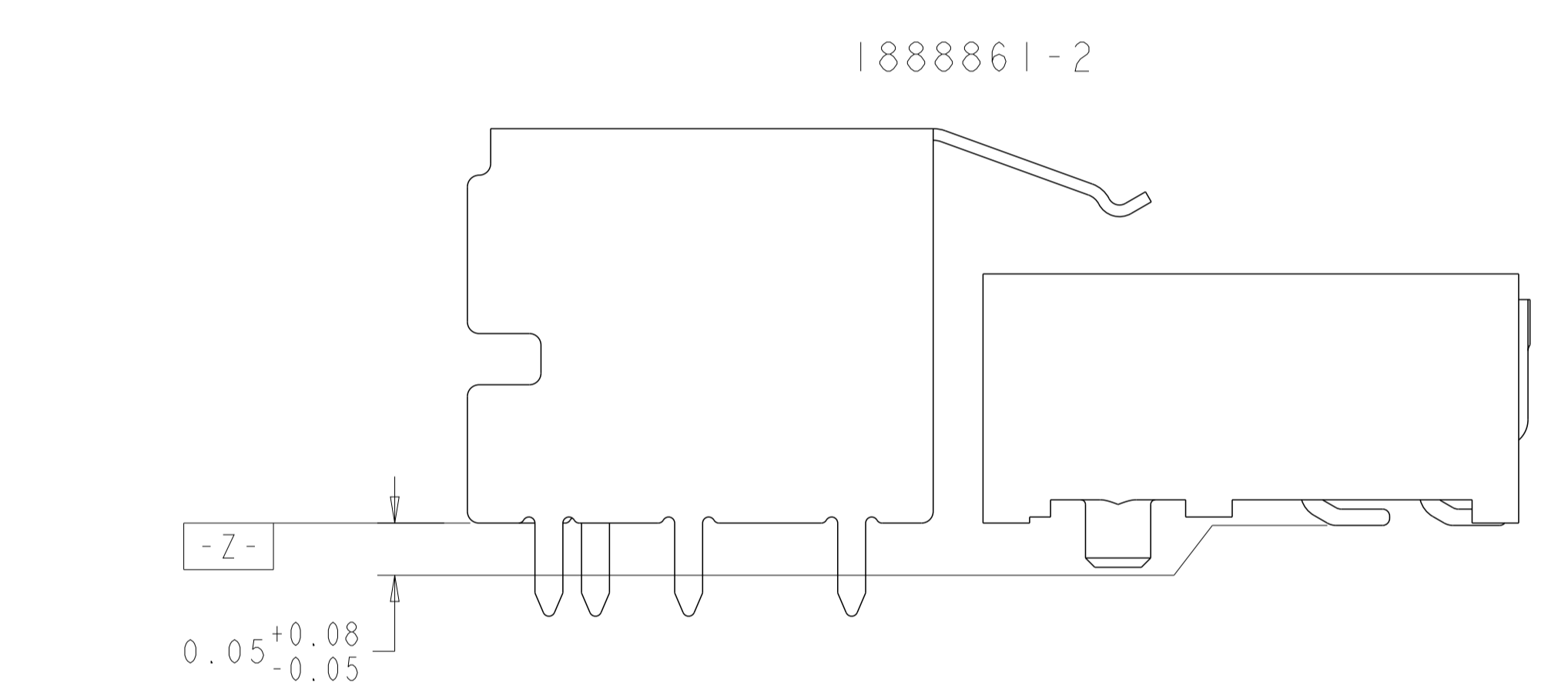
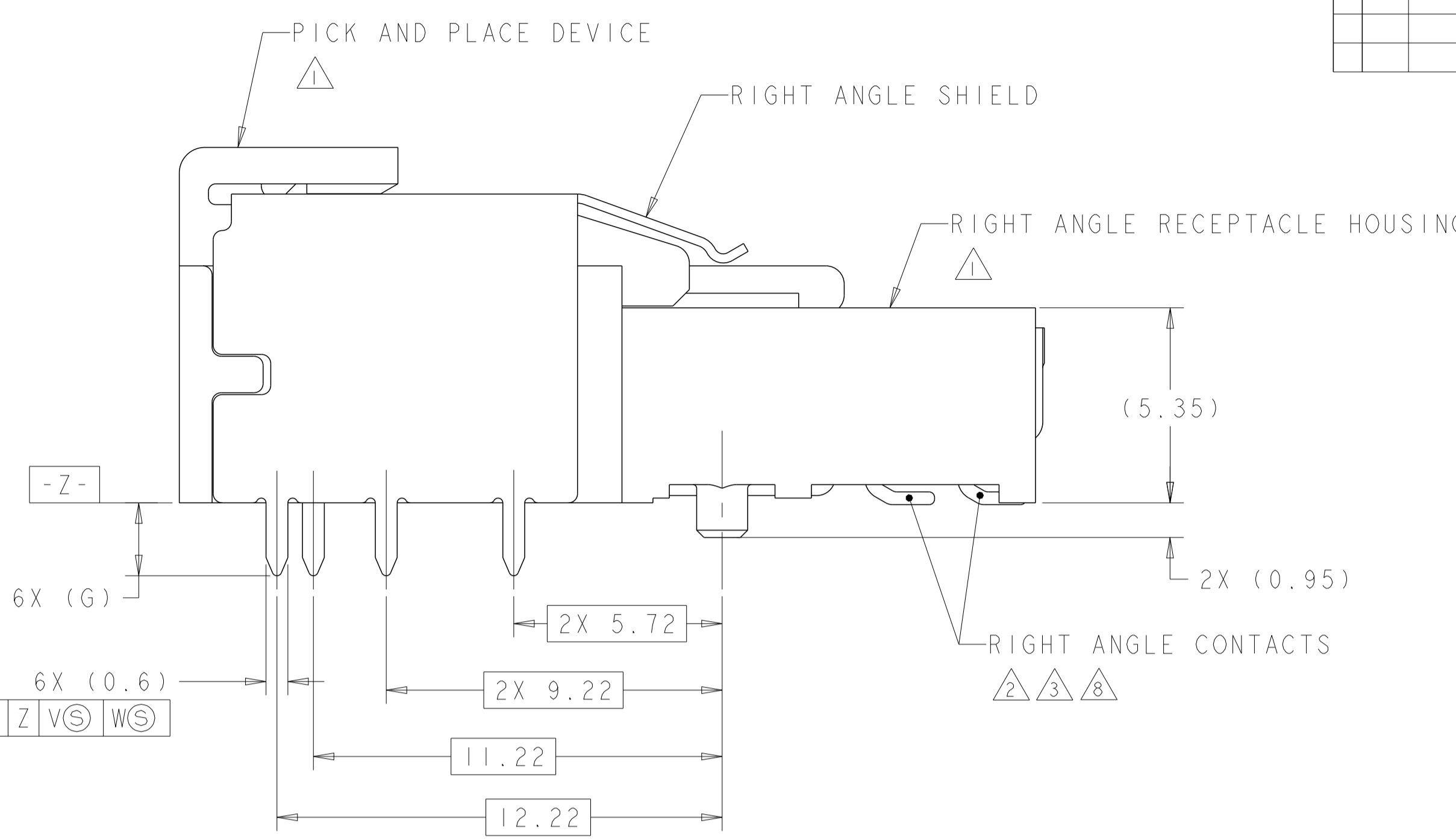
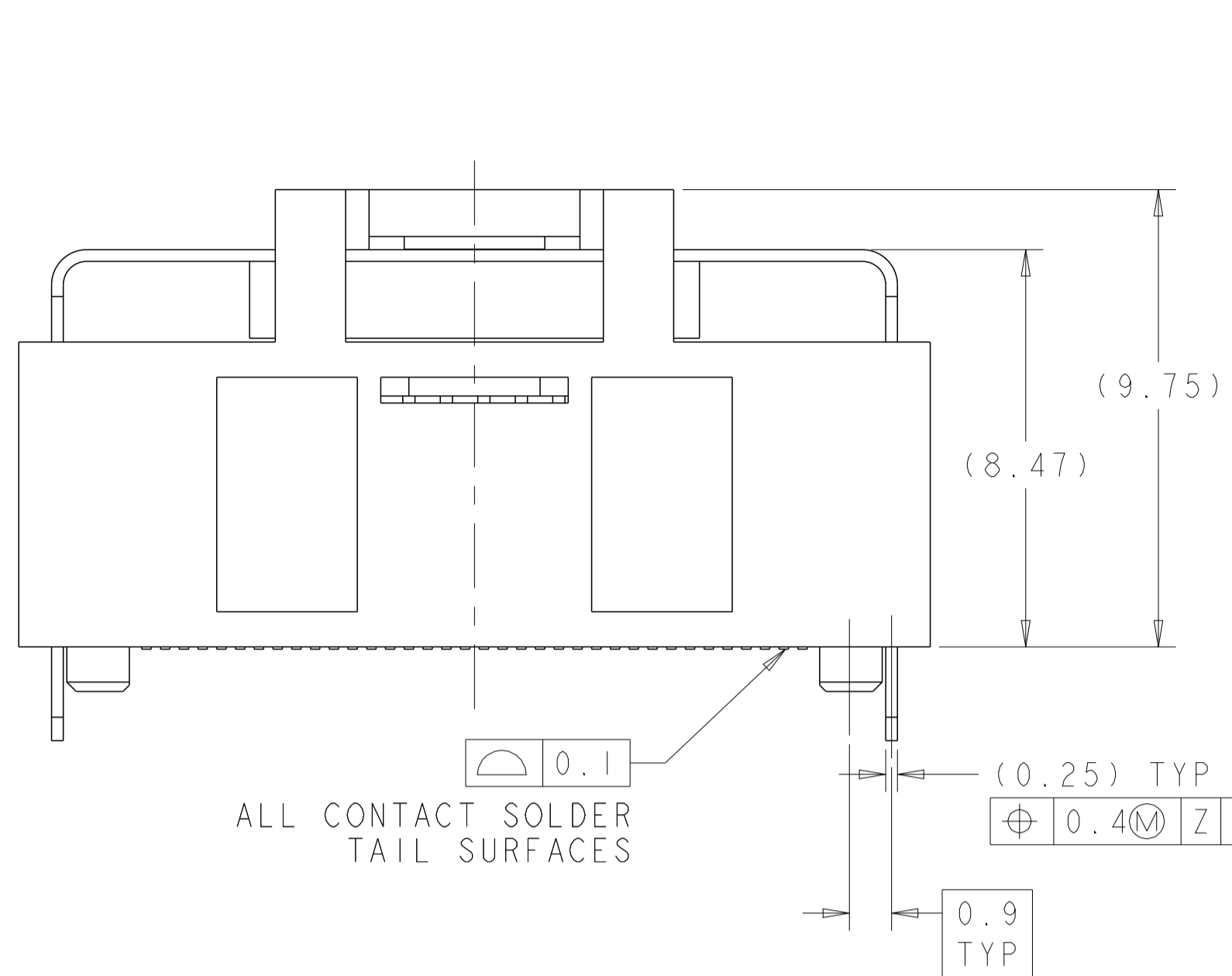

DIMENSIONS: mm 		TOLERANCES UNLESS OTHERWISE SPECIFIED: 0 PLC ± 1 PLC ± 2 PLC ± 3 PLC ± 4 PLC ± ANGLES ± FINISH ±		DWN B. MCMASTER 21FEB07 CHK D. GORENC 21FEB07 APVD D. GORENC 21FEB07 PRODUCT SPEC 108-2234 APPLICATION SPEC WEIGHT CUSTOMER DRAWING		Tyco Electronics Harrisburg, PA 17105-3608 NAME EVERCLEAR Mini-SAS RIGHT ANGLE, INTERNAL RECEPTACLE ASSEMBLY, WITH UNKEYED SHELL SIZE CAGE CODE DRAWING NO. A100779C=1888861 RESTRICTED TO	
MATERIAL SEE NOTES		FINISH SEE TABLE		SCALE 6:1 SHEET 2 OF 3 REV B3		DATE	

LOC	DIST	REVISIONS					
GP	00	P	LTN	DESCRIPTION	DATE	DWN	APVD
		-		SEE SHEET 1			

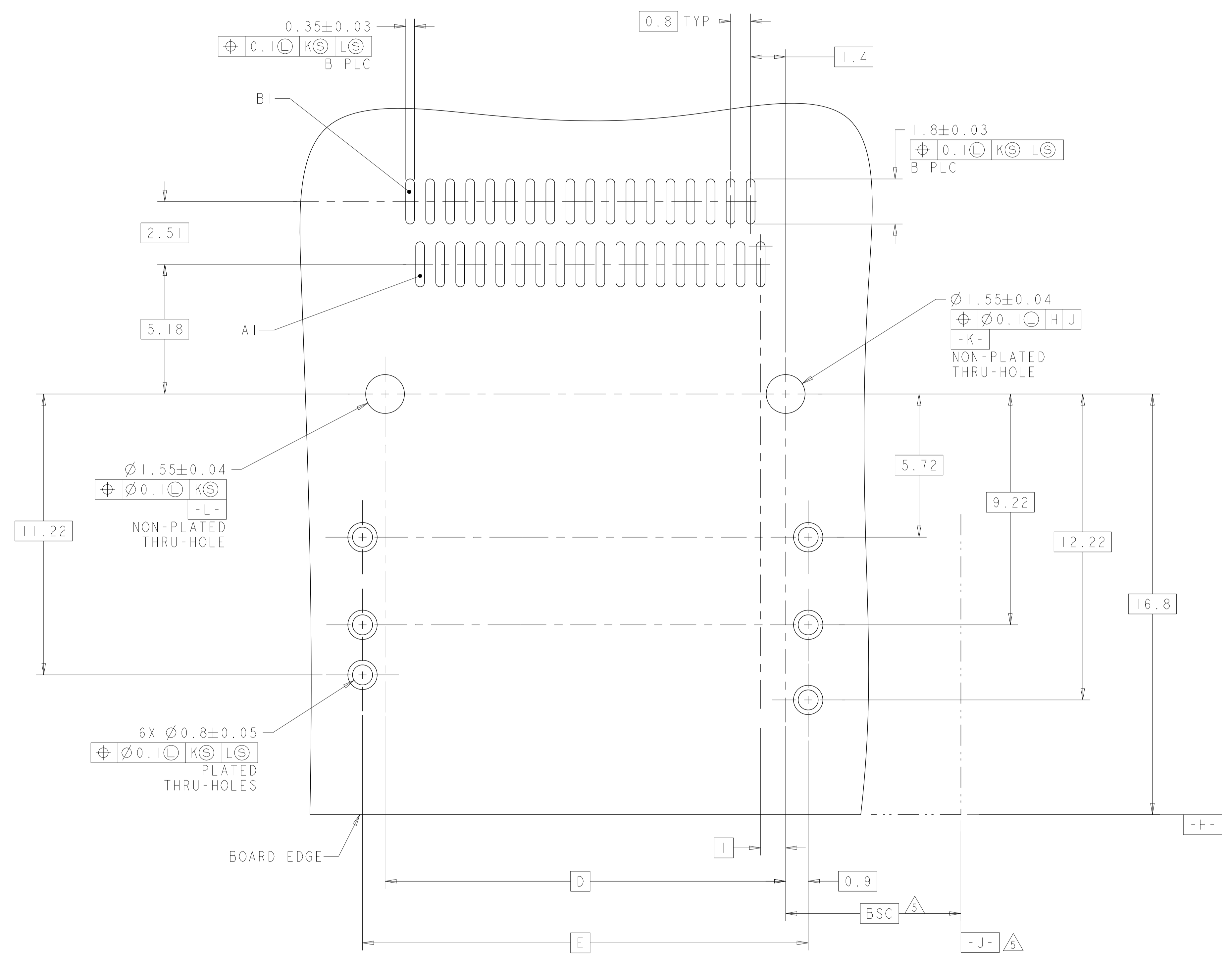

RECOMMENDED PCB LAYOUT
 SCALE 10:1

<small>THIS DRAWING IS UNPUBLISHED. RELEASED FOR PUBLICATION 20. COPYRIGHT 20 BY TYCO ELECTRONICS CORPORATION. ALL RIGHTS RESERVED.</small>		DWN: B. MCMASTER 21FEB07 CHK: D. GORENC 21FEB07 APVD: D. GORENC 21FEB07	Tyco Electronics Harrisburg, PA 17105-3608
DIMENSIONS: mm 		TOLERANCES UNLESS OTHERWISE SPECIFIED: 0 PLC ± 1 PLC ± 2 PLC ± 3 PLC ± 4 PLC ± ANGLES ±	NAME: EVERCLEAR Mini-SAS RIGHT ANGLE, INTERNAL RECEPTACLE ASSEMBLY, WITH UNKEYED SHELL PRODUCT SPEC: 108-2234 APPLICATION SPEC:
MATERIAL: SEE NOTES FINISH: SEE TABLE		WEIGHT: - CUSTOMER DRAWING	SIZE: A100779C=1888861 RESTRICTED TO: - SCALE: 6:1 SHEET 3 OF 3 REV: B3