

Precision Thick Film Chip Resistors

Type: **ERJ XG, 1G**
ERJ 1R, 2R, 3R, 6R
ERJ 3E, 6E, 8E, 14, 12, 1T

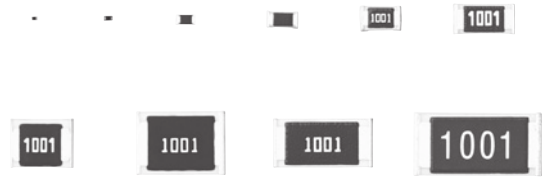

Features

- Small size and lightweight
- High reliability
Metal glaze thick film resistive element and three layers of electrodes
- Compatible with placement machines
Taping packaging available
- Suitable for both reflow and flow soldering
- Low Resistance Tolerance
ERJXG, 1G, 2R, 3E, 6E, 8E, 14, 12, 1T Type : ±1 %
ERJ1R, 2R, 3R, 6R Type : ±0.5 %
- Reference Standards
IEC 60115-8, JIS C 5201-8, EIAJ RC-2134B
- AEC-Q200 qualified (Exemption ERJXG, ERJ1R)
- RoHS compliant

■ **As for Packaging Methods, Land Pattern, Soldering Conditions and Safety Precautions,**
 Please see Data Files

Explanation of Part Numbers

- ERJ1R, 2R, 3R, 6R Type, ±0.5 %

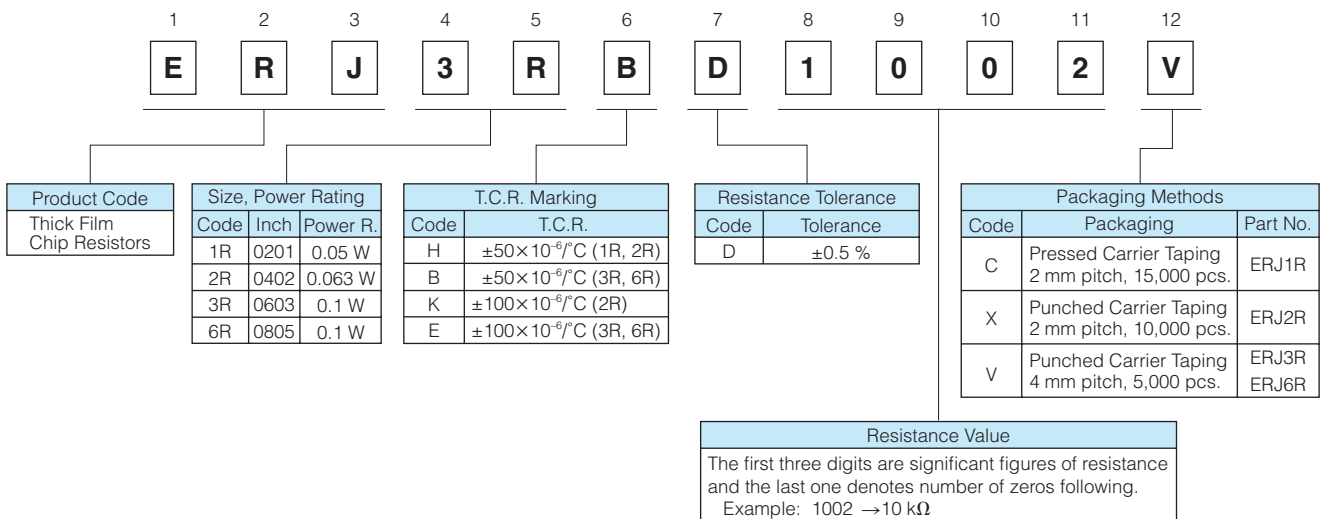

● ERJXG, 1G, 2R, 3E, 6E, 8E, 14, 12, 1T Type, $\pm 1\%$

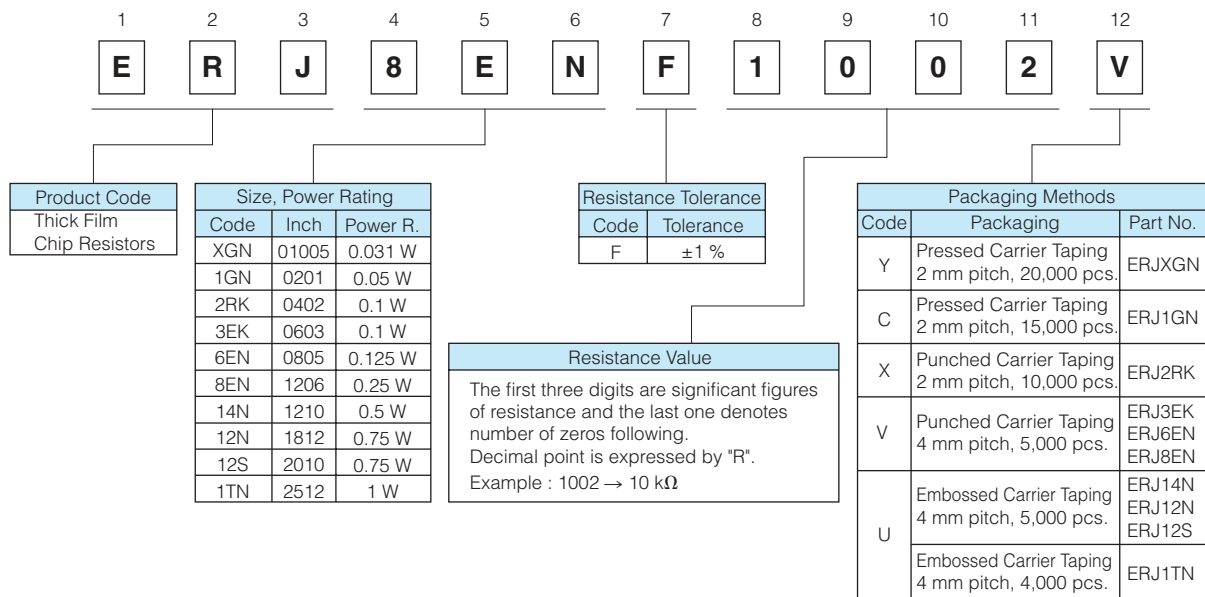

Construction

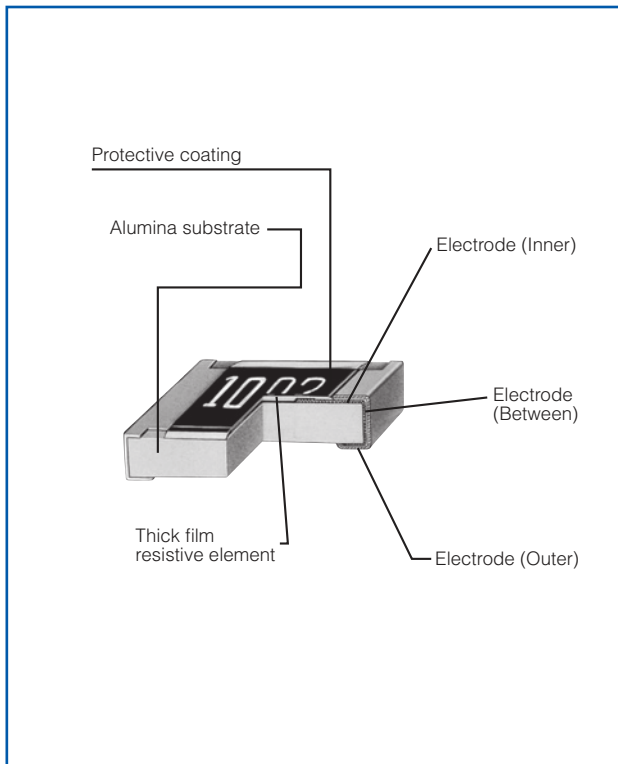

Dimensions in mm (not to scale)

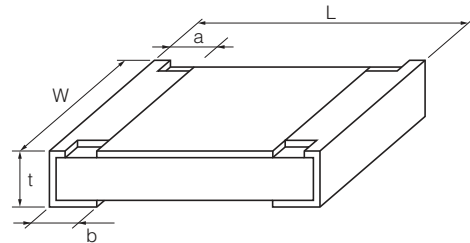

Part No. (inch size)	Dimensions (mm)					Mass (Weight) [g/1000 pcs.]
	L	W	a	b	t	
ERJXG (01005)	0.40 $^{\pm 0.02}$	0.20 $^{\pm 0.02}$	0.10 $^{\pm 0.03}$	0.10 $^{\pm 0.03}$	0.13 $^{\pm 0.02}$	0.04
ERJ1G, 1R (0201)	0.60 $^{\pm 0.03}$	0.30 $^{\pm 0.03}$	0.10 $^{\pm 0.05}$	0.15 $^{\pm 0.05}$	0.23 $^{\pm 0.03}$	0.15
ERJ2R□ (0402)	1.00 $^{\pm 0.05}$	0.50 $^{\pm 0.05}$	0.20 $^{\pm 0.10}$	0.25 $^{\pm 0.05}$	0.35 $^{\pm 0.05}$	0.8
ERJ3R□ ERJ3EK (0603)	1.60 $^{\pm 0.15}$	0.80 $^{\pm 0.15}$	0.30 $^{\pm 0.20}$	0.30 $^{\pm 0.15}$	0.45 $^{\pm 0.10}$	2
ERJ6R□ ERJ6EN (0805)	2.00 $^{\pm 0.20}$	1.25 $^{\pm 0.10}$	0.40 $^{\pm 0.20}$	0.40 $^{\pm 0.20}$	0.60 $^{\pm 0.10}$	4
ERJ8EN (1206)	3.20 $^{\pm 0.05}$	1.60 $^{\pm 0.05}$	0.50 $^{\pm 0.20}$	0.50 $^{\pm 0.20}$	0.60 $^{\pm 0.10}$	10
ERJ14N (1210)	3.20 $^{\pm 0.20}$	2.50 $^{\pm 0.20}$	0.50 $^{\pm 0.20}$	0.50 $^{\pm 0.20}$	0.60 $^{\pm 0.10}$	16
ERJ12N (1812)	4.50 $^{\pm 0.20}$	3.20 $^{\pm 0.20}$	0.50 $^{\pm 0.20}$	0.50 $^{\pm 0.20}$	0.60 $^{\pm 0.10}$	27
ERJ12S (2010)	5.00 $^{\pm 0.20}$	2.50 $^{\pm 0.20}$	0.60 $^{\pm 0.20}$	0.60 $^{\pm 0.20}$	0.60 $^{\pm 0.10}$	27
ERJ1TN (2512)	6.40 $^{\pm 0.20}$	3.20 $^{\pm 0.20}$	0.65 $^{\pm 0.20}$	0.60 $^{\pm 0.20}$	0.60 $^{\pm 0.10}$	45

Ratings

<±0.5 %>

Part No. (inch size)	Power Rating at 70 °C (W)	Limiting Element Voltage ⁽¹⁾ (V)	Maximum Overload Voltage ⁽²⁾ (V)	Resistance Tolerance (%)	Resistance Range (Ω)	T.C.R. (×10 ⁻⁶ /°C)	Category Temperature Range (°C)
ERJ1RH (0201)	0.05	15	30	±0.5	1 k to 1 M (E24, E96)	±50	-55 to +125
ERJ2RH (0402)	0.063	50	100	±0.5	100 to 100 k (E24, E96)	±50	-55 to +125
ERJ2RK (0402)	0.063	50	100	±0.5	10 to 97.6 102 k to 1 M (E24, E96)	±100	-55 to +125
ERJ3RB (0603)	0.1	50	100	±0.5	100 to 100 k (E24, E96)	±50	-55 to +125
ERJ3RE (0603)	0.1	50	100	±0.5	10 to 97.6 102 k to 1 M (E24, E96)	±100	-55 to +125
ERJ6RB (0805)	0.1	150	200	±0.5	100 to 100 k (E24, E96)	±50	-55 to +125
ERJ6RE (0805)	0.1	150	200	±0.5	10 to 97.6 102 k to 1 M (E24, E96)	±100	-55 to +125

<±1 %>

Part No. (inch size)	Power Rating at 70 °C (W)	Limiting Element Voltage ⁽¹⁾ (V)	Maximum Overload Voltage ⁽²⁾ (V)	Resistance Tolerance (%)	Resistance Range (Ω)	T.C.R. (×10 ⁻⁶ /°C)	Category Temperature Range (°C)
ERJXGN (01005)	0.031	15	30	±1	10 to 1 M (E24, E96)	<100 Ω : ±300 100 Ω ≤ : ±200	-55 to +125
ERJ1GN (0201)	0.05	25	50	±1	10 to 1 M ⁽³⁾ (E24, E96)	±200	-55 to +125
ERJ2RK (0402)	0.1	50	100	±1	10 to 1 M ⁽³⁾ (E24, E96)	±100	-55 to +155
ERJ3EK (0603)	0.1	75	150	±1	10 to 1 M (E24, E96)	±100	-55 to +155
ERJ6EN (0805)	0.125	150	200	±1	10 to 2.2 M (E24, E96)	±100	-55 to +155
ERJ8EN (1206)	0.25	200	400	±1	10 to 2.2 M (E24, E96)	±100	-55 to +155
ERJ14N (1210)	0.5	200	400	±1	10 to 1 M (E24, E96)	±100	-55 to +155
ERJ12N (1812)	0.75	200	500	±1	10 to 1 M (E24, E96)	±100	-55 to +155
ERJ12S (2010)	0.75	200	500	±1	10 to 1 M (E24, E96)	±100	-55 to +155
ERJ1TN (2512)	1	200	500	±1	10 to 1 M (E24, E96)	±100	-55 to +155

(1) Rated Continuous Working Voltage (RCWV) shall be determined from $RCWV = \sqrt{\text{Power Rating} \times \text{Resistance Values}}$, or Limiting Element Voltage listed above, whichever less.

(2) Overload (Short-time Overload) Test Voltage (SOTV) shall be determined from $SOTV = 2.5$ (Only ERJ2RK ±1% =2.0) × Power Rating or max. Overload Voltage listed above whichever less.

(3) Please contact us when you need a type with a resistance of less than 10 Ω.

Power Derating Curve

For resistors operated in ambient temperatures above 70 °C, power rating shall be derated in accordance with the figure on the right.

