

Reflective Line Reader Sensor

Type OPB739RWZ

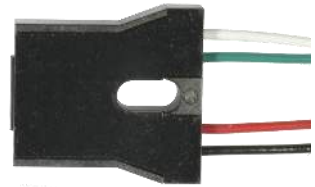

Features:

- Focused for maximum sensitivity
- Phototransistor Output
- 650nm Visible Red LED to optimize detection of dye based inks
- Low-cost plastic housing
- 24" minimum 26AWG wire leads
- Optimal operating distance range 0.015" [.38mm] to 0.045" [1.14mm]

Description:

The **OPB739RWZ** is a reflective line reader sensor. The sensor utilizes a visible red (650nm) LED and an NPN silicon phototransistor mounted side by side on converging optical axes in a black plastic housing. The converging light beam makes this sensor capable of detecting line widths as small as 0.004" [0.1mm] at the optimum distance of 0.030" [0.76mm] from the target. The red LED maximizes the reflected signal contrast of black lines on white backgrounds. Recommended line spacing is .050" minimum.

This sensor can be used with Optek's OCB100CZ auto calibration module to reduce variability from sensor to sensor and to achieve a digital output.

Custom electrical, wire, cabling and connectors are available. Contact your local representative or OPTEK for more information.

Applications:

- Line Reading
- Low Resolution Bar Code Sensing
- Paper edge detection
- Mark detection
- Reflective Optical Encoders

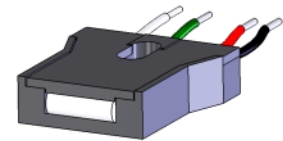
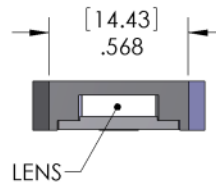

OPB739RWZ

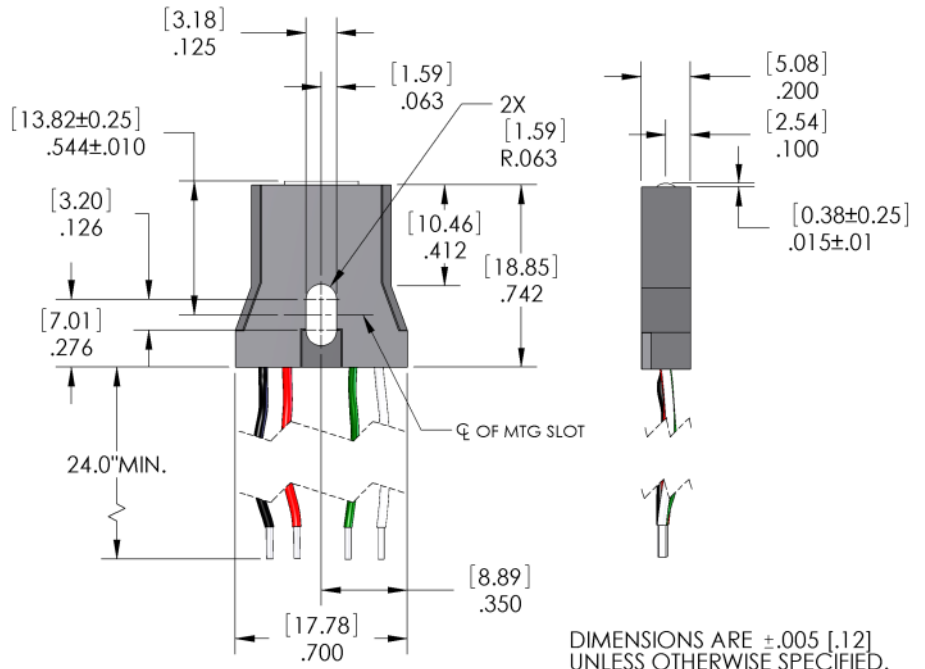
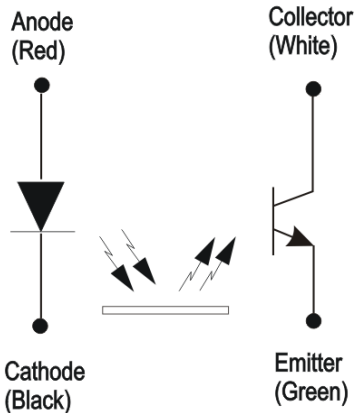

DIMENSIONS ARE ±.005 [.12] UNLESS OTHERWISE SPECIFIED.



General Note
TT Electronics reserves the right to make changes in product specification without notice or liability. All information is subject to TT Electronics' own data and is considered accurate at time of going to print.

OPTEK Technology, Inc.
1645 Wallace Drive, Carrollton, TX 75006 | Ph: +1 972 323 2200
www.optekinc.com | www.ttelectronics.com

Reflective Line Reader Sensor

Type OPB739RWZ



Absolute Maximum Ratings ($T_A = 25^\circ\text{C}$ unless otherwise noted)						
Storage and Operating Temperature Range						-40° C to +85° C
Input LED						
Forward DC Current						40 mA
Reverse DC Voltage						2 V
Power Dissipation						100 mW
Output Phototransistor						
Collector-Emitter Voltage						30 V
Emitter-Collector Voltage						5 V
Power Dissipation						100 mW
Electrical Characteristics ($T_A = 25^\circ\text{C}$ unless otherwise noted)						
SYMBOL	PARAMETER	MIN	TYP	MAX	UNITS	TEST CONDITIONS
Input IR LED						
V_F	Forward Voltage	1.2	2.0	2.3	V	$I_F = 20\text{ mA}$
I_R	Reverse Current	-	-	100	μA	$V_R = 2\text{ V}$
λ_P	Peak Emission Wavelength	-	650	-	nm	$I_F = 20\text{ mA}$
Output Phototransistor						
$V_{(BR)CEO}$	Collector Emitter Breakdown Voltage	30	-	-	V	$I_C = 100\ \mu\text{A}$
$V_{(BR)ECO}$	Emitter Collector Breakdown Voltage	5	-	-	v	$I_E = 100\ \mu\text{A}$
I_{CEO}	Collector Dark Current	-	-	100	nA	$V_{CE} = 10\text{ V}, I_F = 0$
T_r	Rise Time	-	300	-	μs	$V_{CE} = 5\text{ Volts}^{(3)}$
T_f	Fall Time	-	300	-	μs	$I_C = 1\text{ mA}$ $R_L = 20\text{K}\Omega$
Coupled Characteristics						
$I_{C(ON)}$	On-State Collector Current	0.25	-	-	mA	$d = 0.030'' (.76\text{ mm})^{(1)(2)}$ $I_F = 20\text{ mA}, V_{CE} = 5\text{ V}$
$V_{CE(SAT)}$	Collector Emitter Saturation Voltage	-	-	0.4	V	$d = 0.030'' (.76\text{ mm})^{(1)(2)}$ $I_C = 50\ \mu\text{A}, I_F = 20\text{ mA}$
I_{CX}	Crosstalk Collector Current	-	-	0.05	mA	$I_F = 20\text{ mA}, V_{CE} = 5\text{ V}$ No reflective test surface present

Notes:

1. "d" is the distance from the assembly's lens surface to the reflective surface.
2. Measured using 90% diffuse reflectance white test card as the reflecting surface.
3. Typical values by design. Rise and Fall times are not tested.
4. Methanol or Isopropanol are recommended as cleaning agents. Plastic housing is soluble in chlorinated hydrocarbons and ketones.

General Note
TT Electronics reserves the right to make changes in product specification without notice or liability. All information is subject to TT Electronics' own data and is considered accurate at time of going to print.

OPTEK Technology, Inc.
1645 Wallace Drive, Carrollton, TX 75006 | Ph: +1 972 323 2200
www.optekinc.com | www.ttelectronics.com

Reflective Line Reader Sensor

Type OPB739RWZ



Typical Drive Circuit

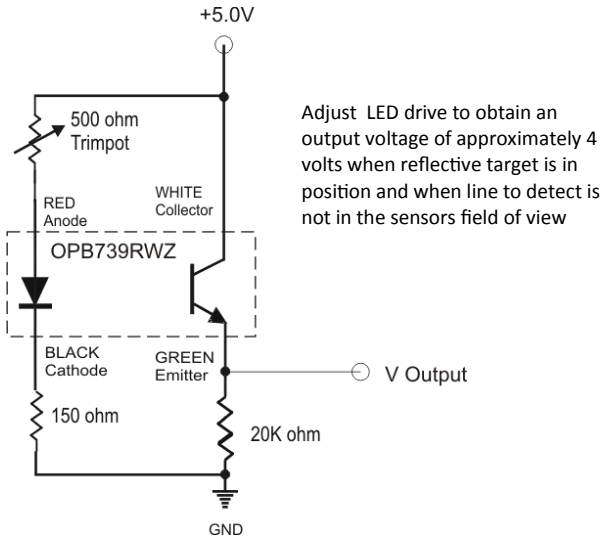

Example reflective target with 0.004", 0.008", and .012" line widths spaced 0.050" apart

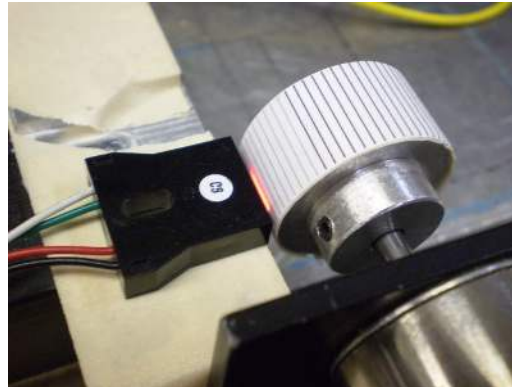

Typical Output Voltage vs Time

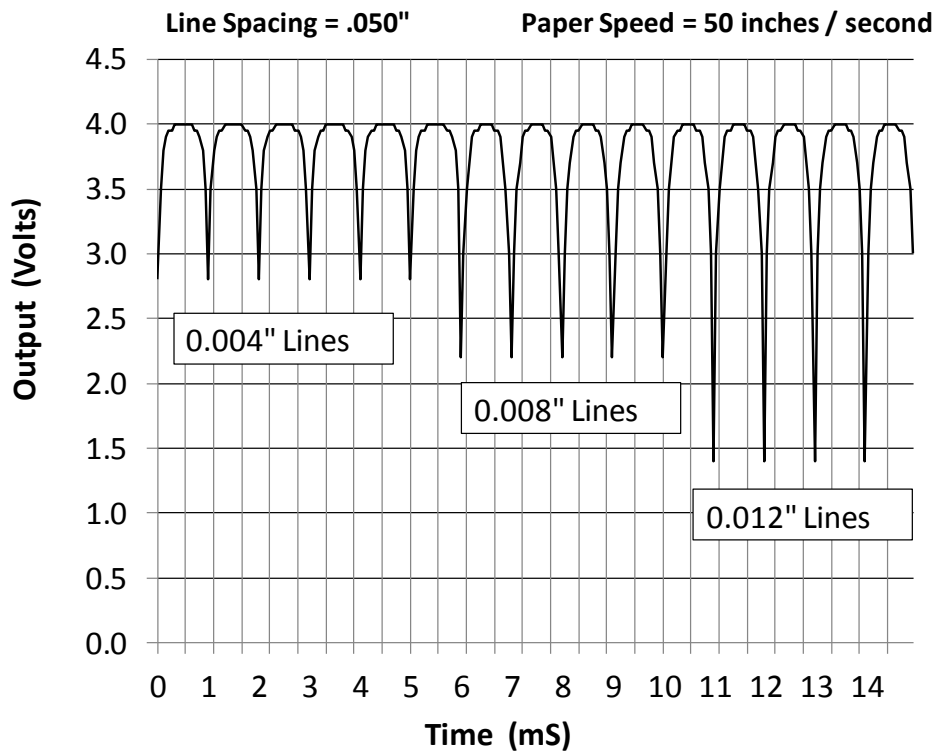

General Note
TT Electronics reserves the right to make changes in product specification without notice or liability. All information is subject to TT Electronics' own data and is considered accurate at time of going to print.

OPTEK Technology, Inc.
1645 Wallace Drive, Carrollton, TX 75006 | Ph: +1 972 323 2200
www.optekinc.com | www.ttelectronics.com

Reflective Line Reader Sensor

Type OPB739RWZ



Typical Performance Curves

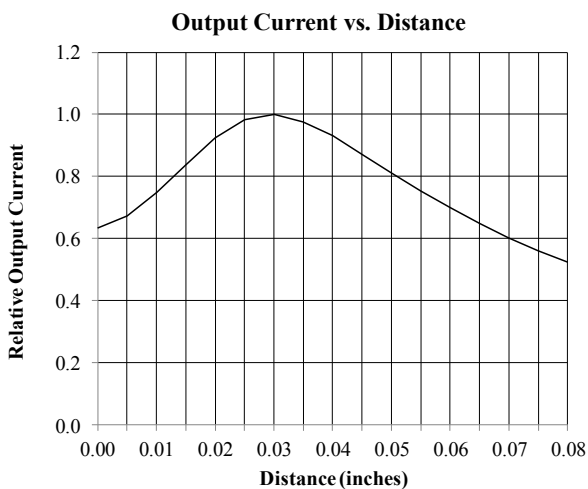
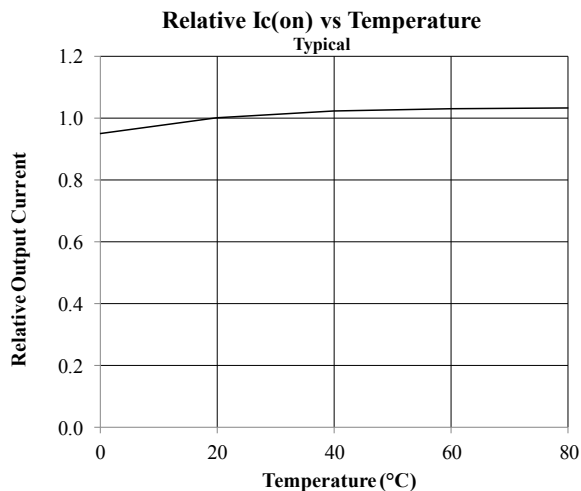
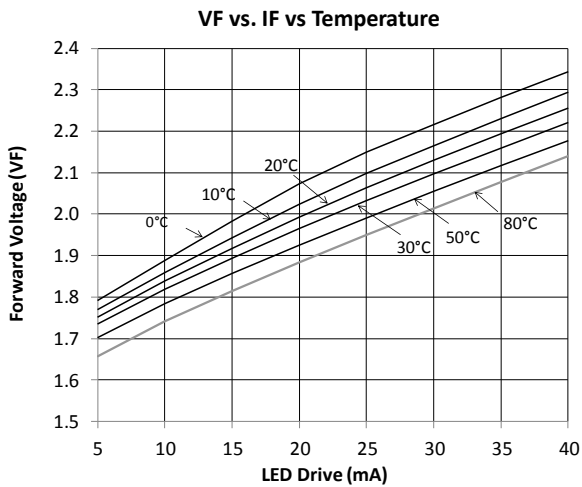

General Note
TT Electronics reserves the right to make changes in product specification without notice or liability. All information is subject to TT Electronics' own data and is considered accurate at time of going to print.

OPTEK Technology, Inc.
1645 Wallace Drive, Carrollton, TX 75006 | Ph: +1 972 323 2200
www.optekinc.com | www.ttelectronics.com