

THIS DRAWING IS UNPUBLISHED. RELEASED FOR PUBLICATION
 © COPYRIGHT BY TYCO ELECTRONICS CORPORATION. ALL RIGHTS RESERVED.

LOC	DIST	REVISIONS					
		P	LTR	DESCRIPTION	DATE	DWN	APVD
AJ	16		F	RDW & REV PER OS14-0114-04	05-10-04	JDP	JL

1. COPPER PER QQ-C-576
2. SILVER PLATE PER QQ-S-365, 5.08μm [.000200] MIN THICKNESS.
3. TIN-LEAD PLATE PER ASTM-B-571, 2.54μm [.000100] MIN THICKNESS, WITH SUPPLEMENTAL ANTI FRETTING LUBRICANT.
4. V SERRATIONS PERMISSIBLE
5. TIN PLATE PER ASTM B-545 WITH SUPPLEMENTAL ANTI-FRETTING LUBRICANT.

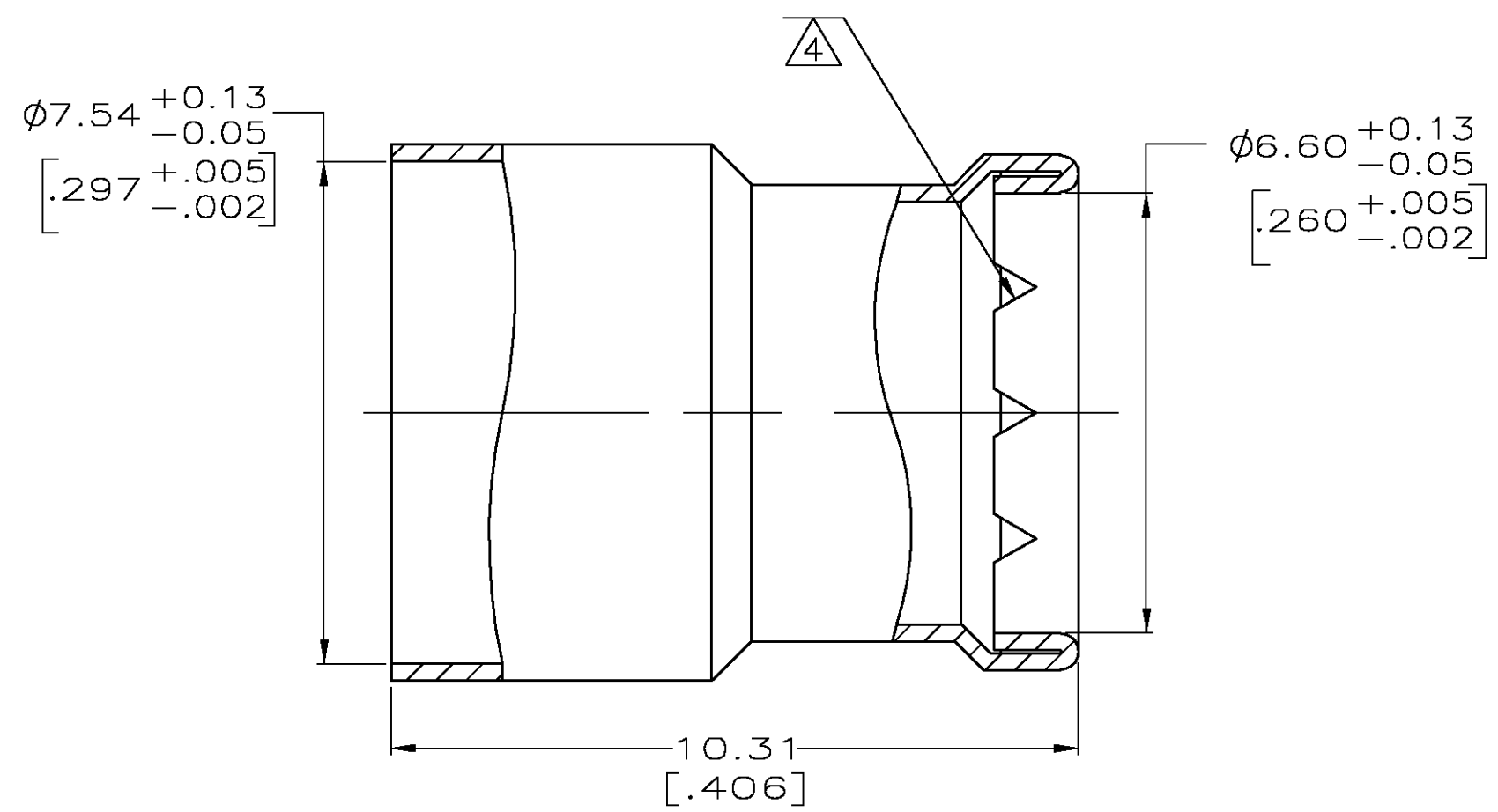

5	9-332224-0
3	1-332224-1
2	1-332224-0
FINISH	PART NUMBER

THIS DRAWING IS A CONTROLLED DOCUMENT.		DWN M.E. COWHER 6-19-92	Tyco Electronics Corporation Harrisburg, Pa 17105-3608													
DIMENSIONS: mm [INCHES]		CHK W.R. GRAY 6-22-92														
TOLERANCES UNLESS OTHERWISE SPECIFIED:		APVD M. E. COWHER 06-22-92	NAME FERRULE, STEP DOWN													
<table border="0"> <tr><td>0 PLC</td><td>± -</td></tr> <tr><td>1 PLC</td><td>± -</td></tr> <tr><td>2 PLC</td><td>± 0.38 [.015]</td></tr> <tr><td>3 PLC</td><td>± -</td></tr> <tr><td>4 PLC</td><td>± -</td></tr> <tr><td>ANGLES</td><td>± -</td></tr> </table>		0 PLC	± -	1 PLC	± -	2 PLC	± 0.38 [.015]	3 PLC	± -	4 PLC	± -	ANGLES	± -	PRODUCT SPEC -	RESTRICTED TO -	
0 PLC	± -															
1 PLC	± -															
2 PLC	± 0.38 [.015]															
3 PLC	± -															
4 PLC	± -															
ANGLES	± -															
MATERIAL SEE NOTES		APPLICATION SPEC -	SIZE A3	CAGE CODE 00779	DRAWING NO C-332224											
FINISH SEE TABLE		WEIGHT -	SCALE 10:1		SHEET 1 OF 1											
CUSTOMER DRAWING			REV F													