

FL SWITCH 300...

Factoryline 5- and 8-port managed switches with optional fiber optic ports and wide temperature ratings



Data sheet
3037_en_B

© PHOENIX CONTACT 2012-06-20

1 Description

The FL SWITCH 300... managed switches provide scalable power for application flexibility and ease of use.

The FL SWITCH 300... consists of 5- and 8-port managed switches that provide maximum redundancy, message filtering and security functions with both wide and normal industrial temperature options. The large IEEE function set meets application and IT requirements while retaining the ease-of-use needed by supporting plant floor personnel. Versions with 10/100Base-T and fiber-optic port combinations are available.

The unique web simplification approach allows users to choose from extensive redundancy, message filtering and security functions while reducing overall system complexity. It allows maintenance personnel complete access to read diagnostic information without login requirements.

Features

- Large capacity message filtering with 64 VLANs and 256 multicast groups provide increased network performance for expanding applications
- -10...60°C and -40...75°C options, 5 or 8 ports and up to 2 multimode fiber ports allow selection of a cost-effective switch
- 802.1x, radius authentication, user accounts and more provide flexible security options
- Unique "cleanup" function hides unused configuration pages, reducing complexity, maintenance and startup times
- Complete redundancy options, including the ability to mix RSTP and the new extended ring (three rings of up to 134 devices per ring), increases network uptime (<15 ms) for IT-compatible and control applications



Make sure you always use the latest documentation.
It can be downloaded from the product at www.phoenixcontact.net/catalog.



This data sheet is valid for all products listed on the following page:

2 Ordering data

Description	Type	Order No.	Pcs. / Pkt.
Managed Ethernet switch with four RJ45 ports at 10/100 Mbps, one SC format fiber optic port and operating temperature of -40°C ... +75°C	FL SWITCH 3004T-FX	2891033	1
Managed Ethernet switch with five RJ45 ports at 10/100 Mbps and operating temperature of -10°C ... +60°C	FL SWITCH 3005	2891030	1
Managed Ethernet switch with five RJ45 ports at 10/100 Mbps and operating temperature of -40°C ... +75°C	FL SWITCH 3005T	2891032	1
Managed Ethernet switch with eight RJ45 ports at 10/100 Mbps and operating temperature of -10°C ... +60°C	FL SWITCH 3008	2891031	1
Managed Ethernet switch with eight RJ45 ports at 10/100 Mbps and operating temperature of -40°C ... +75°C	FL SWITCH 3008T	2891035	1
Managed Ethernet switch with four RJ45 ports at 10/100 Mbps, one ST format fiber optic port and operating temperature of -40°C ... +75°C	FL SWITCH 3004T-FX ST	2891034	1
Managed Ethernet switch with six RJ45 ports at 10/100 Mbps, two SC format fiber optic ports and an operating temperature of -40°C ... +75°C	FL SWITCH 3006T-2FX	2891036	1
Managed Ethernet switch with six RJ45 ports at 10/100 Mbps, two ST format fiber optic ports and an operating temperature of -40°C ... +75°C	FL SWITCH 3006T-2FX ST	2891037	1
Accessories	Type	Order No.	Pcs. / Pkt.
Lockable security element	FL PATCH GUARD	2891424	20
Key for lockable security element	FL PATCH GUARD KEY	2891521	1
Patch cable, CAT5, assembled, 0.3 m (Cable/conductor)	FL CAT5 PATCH 0,3	2832250	10
Patch cable, CAT5, assembled, 0.5 m (Cable/conductor)	FL CAT5 PATCH 0,5	2832263	10
Patch cable, CAT5, assembled, 1.0 m (Cable/conductor)	FL CAT5 PATCH 1,0	2832276	10
Patch cable, CAT5, assembled, 2.0 m (Cable/conductor)	FL CAT5 PATCH 2,0	2832289	10
Patch cable, CAT5, assembled, 3.0 m (Cable/conductor)	FL CAT5 PATCH 3,0	2832292	10
Patch cable, CAT5, assembled, 5.0 m (Cable/conductor)	FL CAT5 PATCH 5,0	2832580	10
Patch cable, CAT5, assembled, 7.5 m (Cable/conductor)	FL CAT5 PATCH 7,5	2832616	10
Patch cable, CAT5, assembled, 10.0 m (Cable/conductor)	FL CAT5 PATCH 10,0	2832629	10

3 Technical data

Dimensions (in mm)

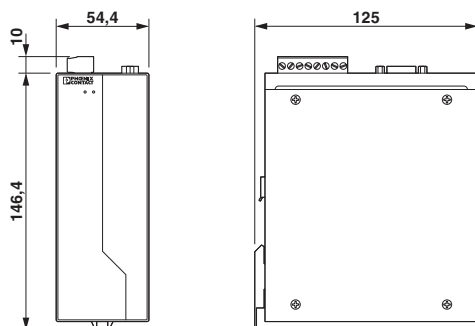

General data

Width	54.4 mm
Height	146.4 mm
Depth	125 mm
Mounting type	NS 35 (IEC 60715) DIN rail
Ambient temperature (storage/transport)	-40°C ... 85°C
Permissible humidity (operation)	5% ... 95% (no condensation)
Permissible humidity (storage/transport)	5% ... 95% (no condensation)
Air pressure (operation)	72 kPa ... 108 kPa (up to 3000 m above mean sea level)
Air pressure (storage/transport)	66 kPa ... 108 kPa (up to 3500 m above mean sea level)
Degree of protection	IP20
Protection class	III, VDE 0106, IEC 60536

Temperature range

FL SWITCH 3004T-FX	-40°C ... 75°C
FL SWITCH 3005	-10°C ... 60°C
FL SWITCH 3005T	-40°C ... 75°C
FL SWITCH 3008	-10°C ... 60°C
FL SWITCH 3008T	-40°C ... 75°C
FL SWITCH 3004T-FX ST	-40°C ... 75°C
FL SWITCH 3006T-2FX	-40°C ... 75°C
FL SWITCH 3006T-2FX ST	-40°C ... 75°C

Weight

FL SWITCH 3004T-FX	920 g
FL SWITCH 3005	920 g
FL SWITCH 3005T	920 g
FL SWITCH 3008	940 g
FL SWITCH 3008T	940 g
FL SWITCH 3004T-FX ST	930 g
FL SWITCH 3006T-2FX	960 g
FL SWITCH 3006T-2FX ST	955 g

Power

Connection method	Pluggable COMBICON screw connections,
Conductor cross section, solid	0.2 mm ² ... 2.5 mm ²
Conductor cross section, stranded	0.2 mm ² ... 2.5 mm ²
Conductor cross section [AWG]	24 ... 12
Supply voltage	24 V DC
Supply voltage range	12 V DC ... 48 V DC
Residual ripple	3.6 V _{pp} (within the permitted voltage range)

Current

	Current draw	Inrush current
FL SWITCH 3004T-FX	230 mA (24 V DC)	9.2 A (2 ms)
FL SWITCH 3005	200 mA (24 V DC)	8.6 A (2 ms)
FL SWITCH 3005T	200 mA (24 V DC)	8.6 A (2 ms)
FL SWITCH 3008	210 mA (24 V DC)	8.6 A (2 ms)
FL SWITCH 3008T	210 mA (24 V DC)	8.6 A (2 ms)
FL SWITCH 3004T-FX ST	230 mA (24 V DC)	9.2 A (2 ms)
FL SWITCH 3006T-2FX	330 mA (24 V DC)	8.2 A (2 ms)
FL SWITCH 3006T-2FX ST	330 mA (24 V DC)	8.2 A (2 ms)

Port configurations

	No. of RJ45 ports	No. of fiber optic ports
FL SWITCH 3004T-FX	4	1 (SC)
FL SWITCH 3005	5	
FL SWITCH 3005T	5	
FL SWITCH 3008	8	
FL SWITCH 3008T	8	
FL SWITCH 3004T-FX ST	4	1 (ST)
FL SWITCH 3006T-2FX	6	2 (SC)
FL SWITCH 3006T-2FX ST	6	2 (ST)

Ethernet (RJ45)

Connection method	RJ45
Transmission speed	10/100 MBit/s
Transmission length	100 m

Fiber optic interface

Connection method	SC
Transmission speed	100 MBit/s (SC-D, full duplex)
Wavelength	1300/1310 nm
Transmission length	12.1 km (fiberglass with F-G 62.5/125 0.7 dB/km F1000) 3.3 km (fiberglass with F-G 62.5/125 2.6 dB/km F600) 7.1 km (fiberglass with F-G 50/125 0.7 dB/km F1200) 3.1 km (fiberglass with F-G 50/125 1.6 dB/km F800)

Electrical isolation/isolation of the voltage areas

Supply voltage/functional earth ground	500 V, 1 min
--	--------------

Mechanical tests

Shock test in acc. with IEC 60068-2-27	25g, 11 ms half-sine shock pulse
Vibration resistance in acc. with IEC 60068-2-6	5g, 150 Hz, Criterion 3
Free fall in acc. with IEC 60068-2-32	1 m

4 Managed switch functions

Ease of use for everyone

FL SWITCH 300... switches include context-sensitive help for hardware and firmware functions. Web viewing modes can be configured for different user types, such as maintenance, control engineers or network administrators, providing quick access to data.

- Monitor mode provides one-click access to read-only diagnostics – no logins and no searching for web pages
- Administrative mode allows access to the complete range of switch functions and customizing of the user-mode web pages
- User mode can be customized to include only those functions that are actually used, whether for start up or on-going maintenance purposes. With one click, unwanted web pages are hidden from the user.

Telnet	Yes
SNMP V1, V2	Yes
Serial interface	Password protected for basic maintenance addressing and major function access
Transfer of firmware and configuration files	via TFTP
Web view simplification	Monitor, user and administrative views. User mode is customizable by account type or individual.
Network addressing	BOOTP or DHCP

Mix IT and high-performance redundancy

The extended ring redundancy protocol allows network recovery time in as little as 15 ms (18 ms between rings) and configurations up to 134 devices. Coupling of up to three rings of 134 switches each allows redundancy systems of over 300 switches. Coupling rings and ring ports may only be connected to other switches (no other devices allowed). Both extended ring and IEEE redundancy may be operated simultaneously in the switch. Complete IEEE STP/RSTP/MST options, with the additional option of extended ring redundancy, serves a broad range of IT compatibility and industrial performance-based applications.

Powerful network performance options

The FL SWITCH 300... provides a complete range of message filtering and network performance-increasing functions. Performance may be scaled from basic to increasingly sophisticated functions.

IGMP snooping/query	Yes; 256 multicast groups and GMRP support
QoS: priority queus	4
QoS: ToS: COS diff serv	Yes
Link aggregation trunking	Yes; up to four ports combined with LACP trunk control
Flow control	User enable/disable by port
Bandwidth rate control by message type by port	Yes - percent bandwidth by message type to separate ingress/egress transfer rates by port
Time synchronization	SNTP
VLAN Static	16 port-based VLANs, 64 maximum; tagging-based VLAN supported with >4000 address range
VLAN Dynamic (tagging based)	GVRP

Tailor security functions to your facility

The FL SWITCH 300... provides a wide array of security functions that can be tailored to guard against unauthorized network access. Scaleable security measures can be used to protect against unauthorized access by people, devices or network communications.

Secure people access: General	Enable/disable Web interface and Telnet, 802.1x Radius Authentication
Secure people access: Manage access to switch configuration parameters	User login accounts, customization of read and read/write access, and control of function access for each type of account or on an individual basis
Secure device access	MAC address filtering (up to 24) by port; enable/disable ports; and global MAC discard
Secure network access	SNMP V3 with encryption; enable/disable SNMP; https secure web access

5 Structure

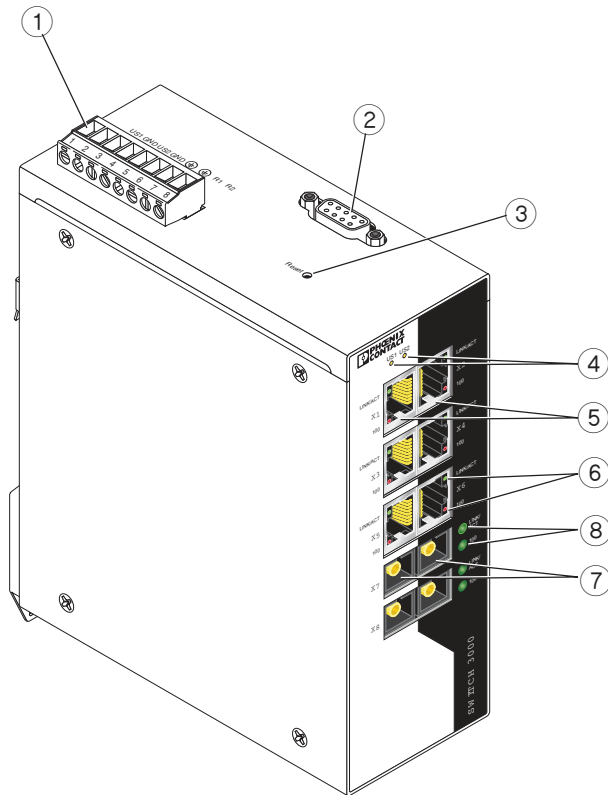

Figure 1 Structure (FL SWITCH 3006T-2FX shown)

- 1 Power supply/remote alarm connector
- 2 DB-9 serial port (RS-232)
- 3 Reset button
- 4 Power LEDs (US1/US2)
- 5 RJ45 ports
- 6 RJ45 port LEDs (LNK/ACT and 10/100 Mbps)
- 7 Fiber optic ports
- 8 Fiber optic port LEDs (LNK/ACT and 100 Mbps)

6 Installation



This device is designed for SELV and PELV operation according to IEC 61140/EN 61140.

Assembly

Position the device on the upper edge of the DIN rail and snap it into place with a downward motion.

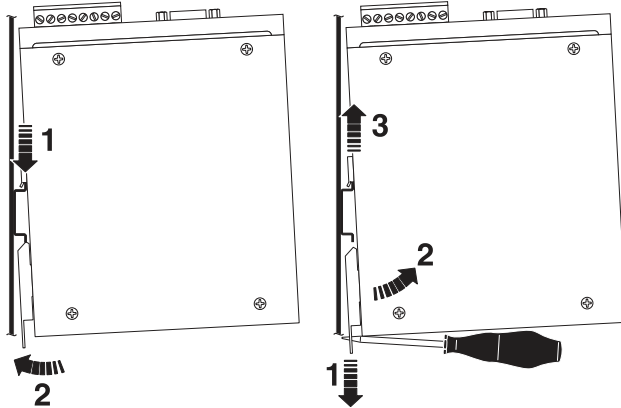

Removal

Pull the release lever open using a screwdriver. Rotate the device upward and remove from DIN rail.

Power supply

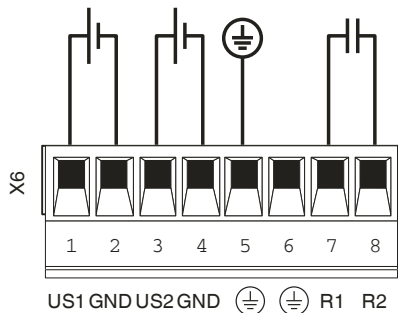

Figure 2 Redundant power supply connection

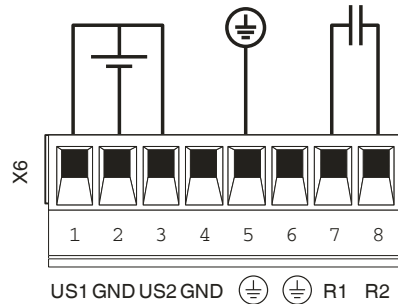

Figure 3 Single power supply connection

Snapping the switch onto a grounded rail connects it to the ground potential. In an environment particularly prone to EMI, noise immunity can be increased through the additional ground connections on the power connector.

Alarm contacts

FL SWITCH 300... switch provides contacts (R1 and R2) to provide an external alarm in the event of a failure. If either power supply fails (≤ 12 V) or a port fails (LNK), the internal dry contacts close.



Individual ports that are monitored for alarm notification are configured using the software interface. Refer to the User Manual for details on configuration.