

P/N	PLATING	DIM'A	DIM'B	DIM'C	HUSING COLOR	REMARK
67492-1630	NOTES 2 (A)					
67492-1631	NOTES 2 (B)	2.70	4.45	2.80	BLACK	WITH CAP
67492-1632	NOTES 2 (C)					
67492-1730	NOTES 2 (A)					
67492-1731	NOTES 2 (B)	1.95	3.70	2.05	WHITE	WITH CAP
67492-1732	NOTES 2 (C)					
67492-1620	NOTES 2 (A)					
67492-1621	NOTES 2 (B)	2.70	4.45	2.80	BLACK	WITHOUT CAP
67492-1622	NOTES 2 (C)					
67492-1720	NOTES 2 (A)					
67492-1721	NOTES 2 (B)	1.95	3.70	2.05	WHITE	WITHOUT CAP
67492-1722	NOTES 2 (C)					

- NOTES:
- MATERIAL:
 - HOUSING: HIGH TEMPERATURE THERMAL PLASTIC, UL94V-0, COLOR: REFER TO TABLE IN SHEET 2.
 - TERMINAL: COPPER ALLOY, FORKLOCK: COPPER ALLOY.
 - TERMINAL PLATING:
 - CONTACT AREA:
 - (A) GOLD FLASH,
 - (B) GOLD, THICKNESS=0.76 MICRONS MINIMUM,
 - (C) GOLD, THICKNESS=0.38 MICRONS MINIMUM,
 - SOLDER AREA: TIN, THICKNESS=1.27 MICRONS MINIMUM, UNDER PLATE: NICKEL, THICKNESS=1.27 MICRONS MINIMUM.
 - FORKLOCK PLATING:
 - SOLDER AREA: TIN, THICKNESS=1.27 MICRONS MINIMUM, UNDER PLATE: NICKEL, THICKNESS=1.27 MICRONS MINIMUM.
 - PRODUCT SPECIFICATION: REFER TO PS-67492-001.
 - PACKAGING METHOD: TAPE REEL, 67492-163* REFER TO PK-67492-005, 67492-173* REFER TO PK-67492-006.
 - MATING PARTS: 87703/87672.

RTM	EC NO:	2006/02/08	QUALITY SYMBOLS ▽=0 ∇=0	GENERAL TOLERANCES (UNLESS SPECIFIED)		DIMENSION STYLE MM ONLY		SCALE 2:1	DESIGN UNITS METRIC	THIRD ANGLE PROJECTION	
	DR:WJGLL	2006/02/28		mm	INCH	DRAWN BY DIXON LI	DATE 2005/12/22	SATA HOST RECEPTACLE R/A SMT TYPE -LEAD FREE-			
	CHKD:	2006/03/01		4 PLACES ± --- ± ---	3 PLACES ± --- ± ---	CHECKED BY JANNY ZENG	DATE 2005/12/22				
	APPR:GRWA			2 PLACES ± 0.15 ± ---	1 PLACE ± 0.25 ± ---	APPROVED BY GRATE MA	DATE 2005/12/22	MOLEX INCORPORATED			
REV	DESCRIPTION		ANGULAR ± 3 °		MATERIAL NO.		DOCUMENT NO.		SHEET NO.		
B			DRAFT WHERE APPLICABLE MUST REMAIN WITHIN DIMENSIONS		SEE TABLE		SD-67492-008		1 OF 1		
SIZE A3		THIS DRAWING CONTAINS INFORMATION THAT IS PROPRIETARY TO MOLEX INCORPORATED AND SHOULD NOT BE USED WITHOUT WRITTEN PERMISSION									

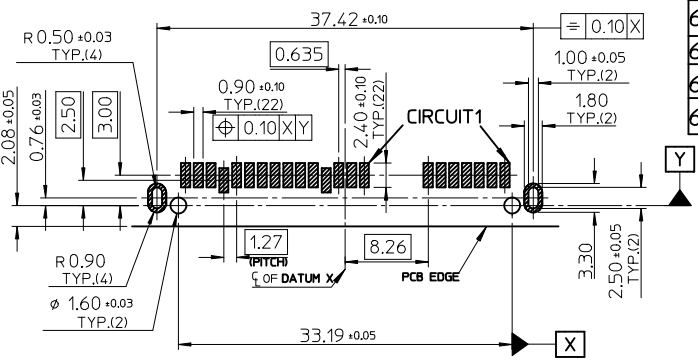
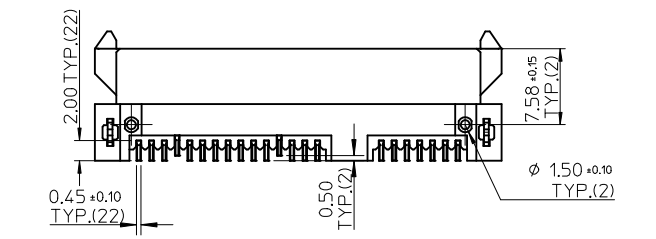
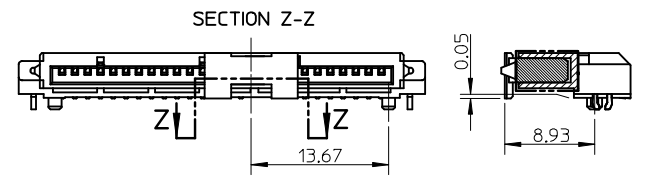
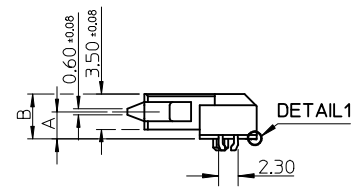
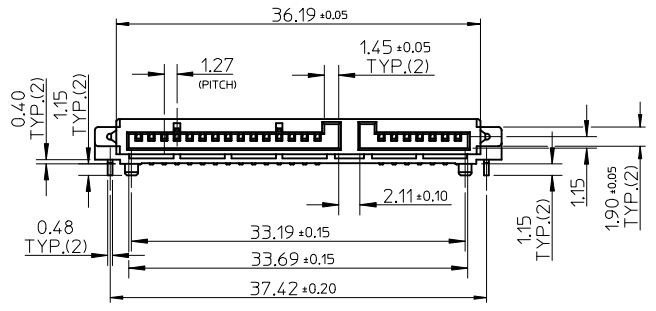
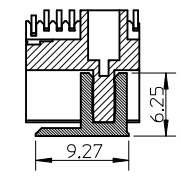
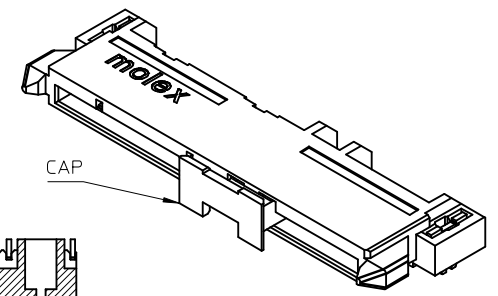
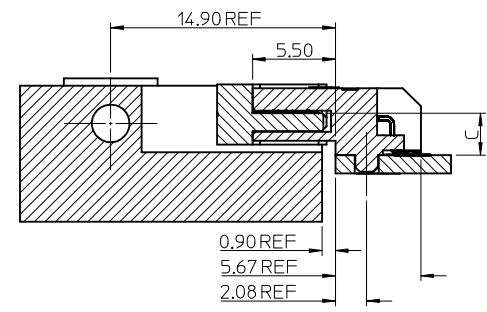
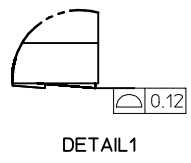
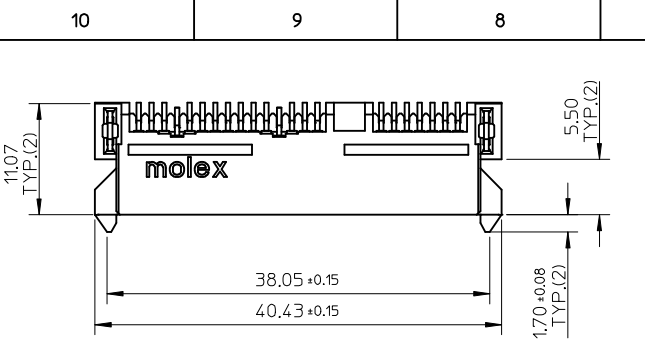

P/N	PLATING	DIM'A	DIM'B	DIM'C	HOUSING COLOR	REMARK
67492-1630	NOTES 2 (A)					
67492-1631	NOTES 2 (B)	2.70	4.45	2.80	BLACK	WITH CAP
67492-1632	NOTES 2 (C)					
67492-1730	NOTES 2 (A)					
67492-1731	NOTES 2 (B)	1.95	3.70	2.05	WHITE	WITH CAP
67492-1732	NOTES 2 (C)					
67492-1620	NOTES 2 (A)					
67492-1621	NOTES 2 (B)	2.70	4.45	2.80	BLACK	WITHOUT CAP
67492-1622	NOTES 2 (C)					
67492-1720	NOTES 2 (A)					
67492-1721	NOTES 2 (B)	1.95	3.70	2.05	WHITE	WITHOUT CAP
67492-1722	NOTES 2 (C)					

- NOTES:
- MATERIAL:
 - HOUSING: HIGH TEMPERATURE THERMAL PLASTIC, UL94V-0, COLOR: REFER TO TABLE IN SHEET 2.
 - TERMINAL: COPPER ALLOY, FORKLOCK: COPPER ALLOY.
 - TERMINAL PLATING:
 - CONTACT AREA:
 - (A) GOLD FLASH,
 - (B) GOLD, THICKNESS=0.76 MICRONS MINIMUM,
 - (C) GOLD, THICKNESS=0.38 MICRONS MINIMUM,
 - SOLDER AREA: TIN, THICKNESS=1.27 MICRONS MINIMUM, UNDER PLATE: NICKEL, THICKNESS=1.27 MICRONS MINIMUM.
 - FORKLOCK PLATING:
 - SOLDER AREA: TIN, THICKNESS=1.27 MICRONS MINIMUM, UNDER PLATE: NICKEL, THICKNESS=1.27 MICRONS MINIMUM.
 - PRODUCT SPECIFICATION: REFER TO PS-67492-001.
 - PACKAGING METHOD: TAPE REEL, 67492-163* REFER TO PK-67492-005, 67492-173* REFER TO PK-67492-006.
 - MATING PARTS: 87703/87672.

RTM	EC NO:	2006/02/08	QUALITY SYMBOLS ▽=0 ∇=0	GENERAL TOLERANCES (UNLESS SPECIFIED)		DIMENSION STYLE MM ONLY		SCALE 2:1	DESIGN UNITS METRIC	THIRD ANGLE PROJECTION	
	DRW:WGLLI	2006/02/28		mm	INCH	DRAWN BY DIXON LI	DATE 2005/12/22	SATA HOST RECEPTACLE R/A SMT TYPE -LEAD FREE-			
	CHKD:	2006/03/01		4 PLACES ± --- ± ---	3 PLACES ± --- ± ---	CHECKED BY JANNY ZENG	DATE 2005/12/22				
	APPR:GRM/A			2 PLACES ± 0.15 ± ---	1 PLACE ± 0.25 ± ---	APPROVED BY GRATE MA	DATE 2005/12/22	MOLEX INCORPORATED		DOCUMENT NO.	SHEET NO.
REV	DESCRIPTION		ANGULAR ± 3 °		MATERIAL NO.		SEE TABLE		SD-67492-008	1 OF 1	
DRAFT WHERE APPLICABLE MUST REMAIN WITHIN DIMENSIONS			SIZE A3		THIS DRAWING CONTAINS INFORMATION THAT IS PROPRIETARY TO MOLEX INCORPORATED AND SHOULD NOT BE USED WITHOUT WRITTEN PERMISSION						