

THIS DRAWING IS UNPUBLISHED. RELEASED FOR PUBLICATION  
 © COPYRIGHT BY TYCO ELECTRONICS CORPORATION. ALL RIGHTS RESERVED.

LOC	DIST	REVISIONS					
GP	00	P	LTR	DESCRIPTION	DATE	DWN	APVD
		L		REVISED PER EC 0S13-0257-04	11-15-04	LV	JG

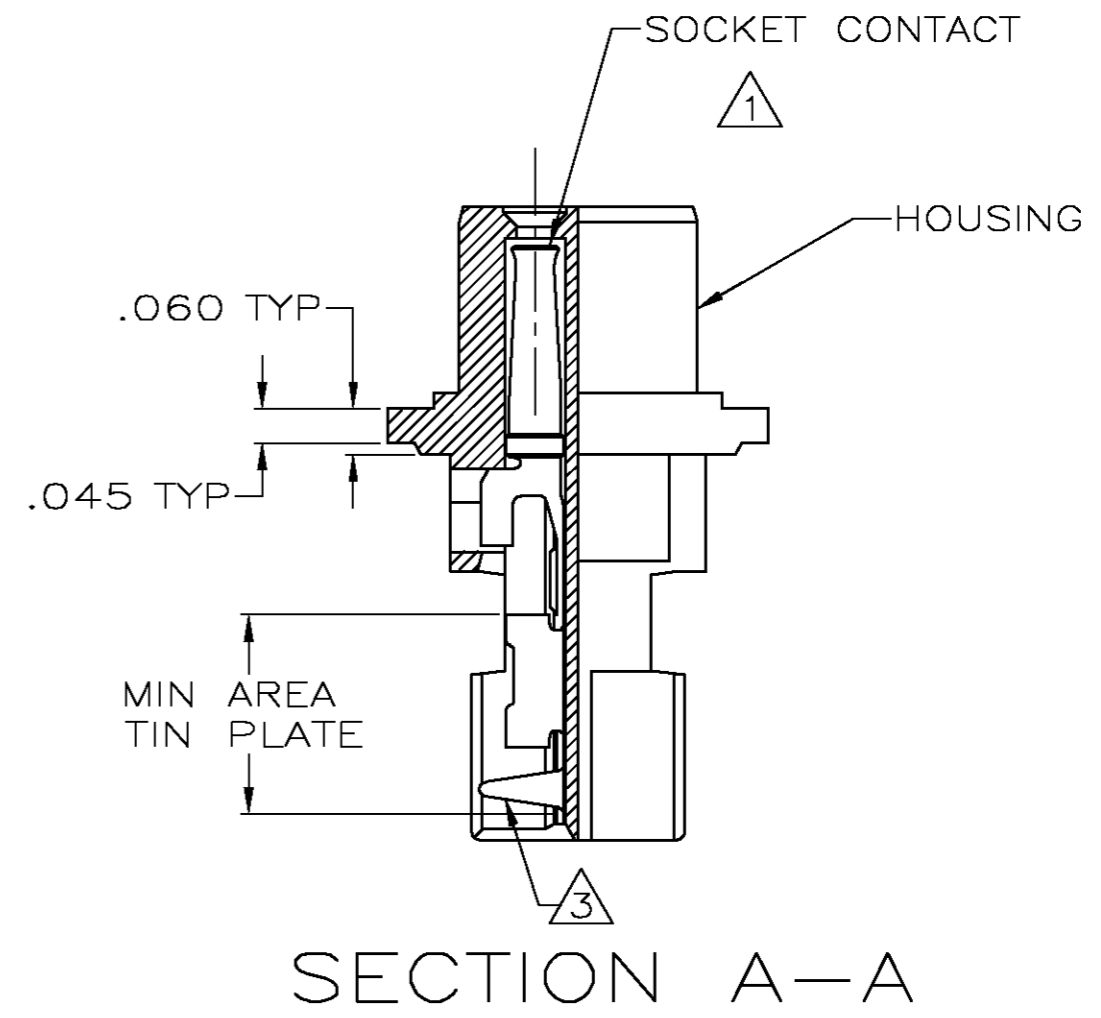
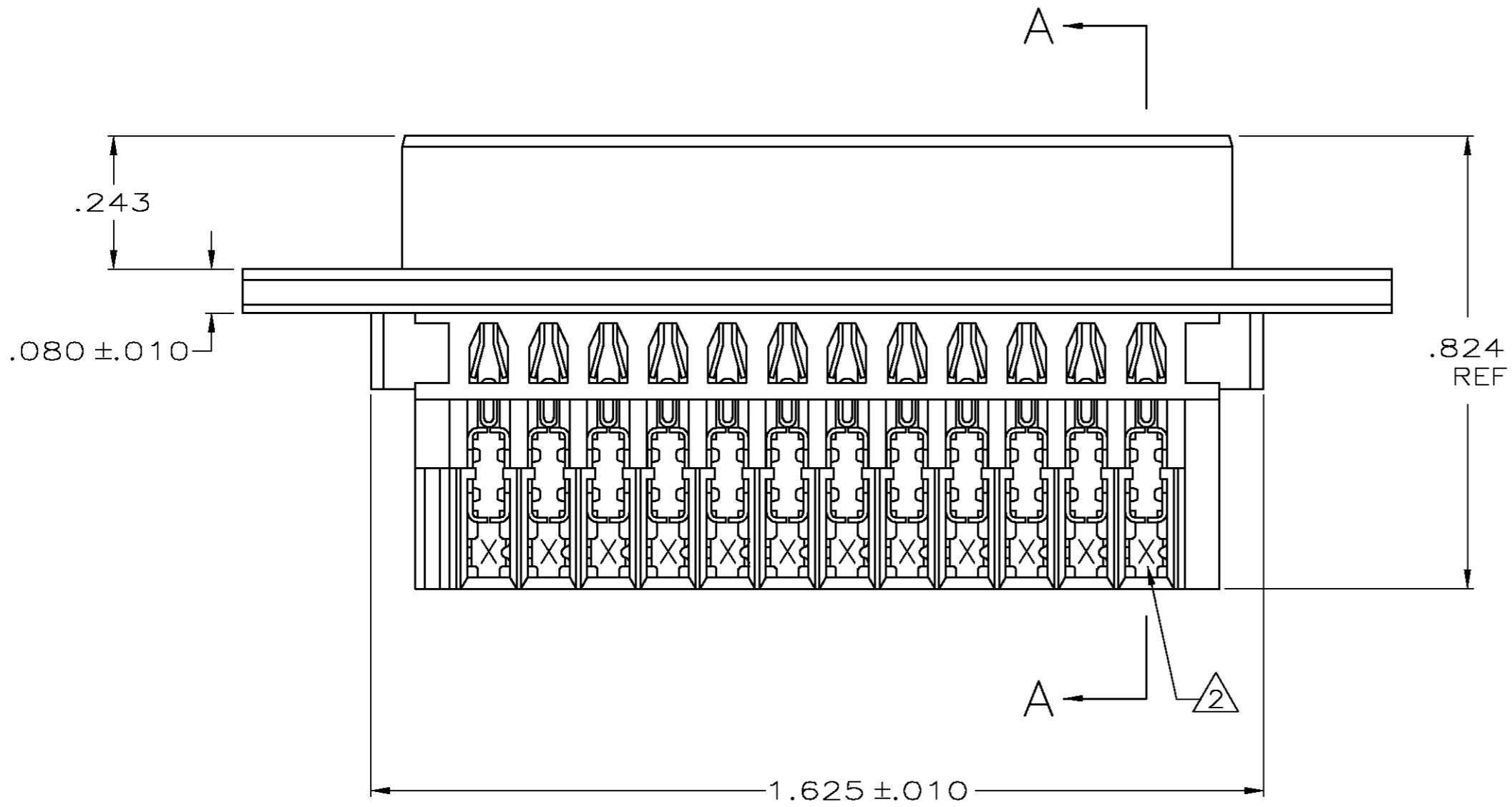
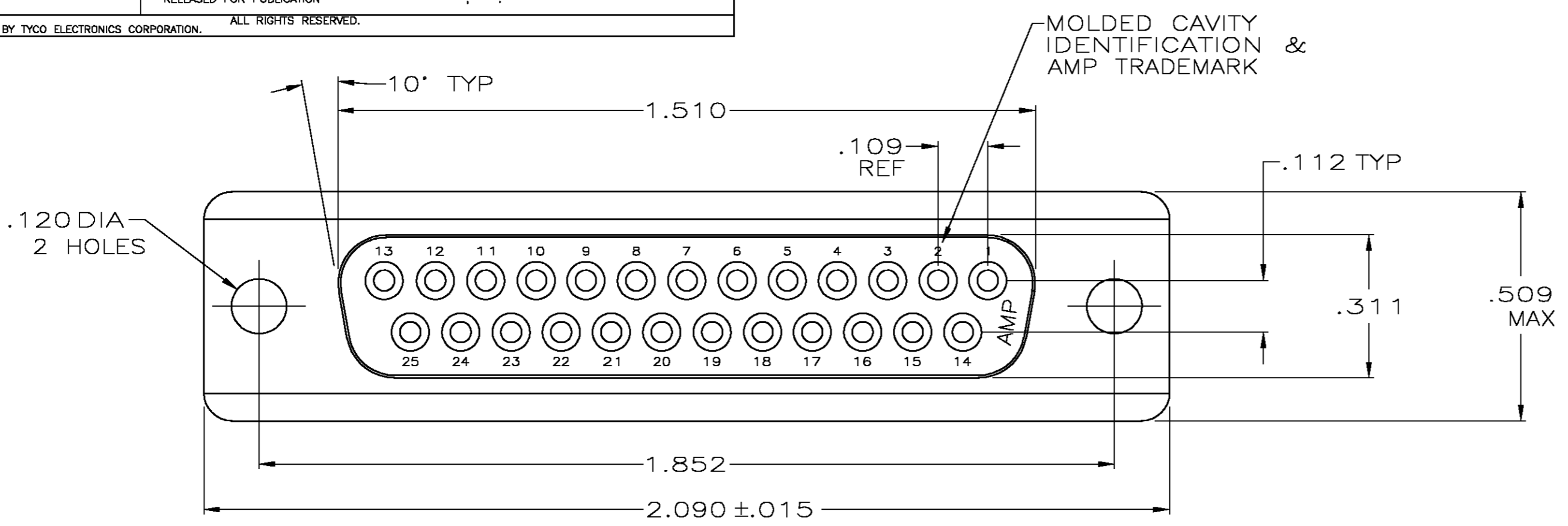

- ① HOUSING FULLY LOADED WITH CONTACTS.
- ② NUMBER ON CONTACT INDICATES WIRE RANGE.
- ③ CONTACT INSULATION RANGE: .060 MAXIMUM O.D.
- ④ CONTACTS PLATED .000030 GOLD ON MATING END FOR .100 MIN LENGTH. .000100-.000200 THICK BRIGHT TIN OR BRIGHT TIN-LEAD IN AREA SHOWN. .000050 THICK NICKEL UNDERPLATE ON ENTIRE CONTACT.
- ⑤ CONTACTS PLATED WITH GOLD FLASH ON MATING END FOR .100 MIN LENGTH. .000100-.000200 THICK BRIGHT TIN OR BRIGHT TIN-LEAD IN AREA SHOWN. .000030 THICK NICKEL UNDERPLATE ON ENTIRE CONTACT.
- ⑥ CONTACTS PLATED .000030 GOLD ON MATING END FOR .100 MIN LENGTH. .000100-.000200 THICK MATTE TIN IN AREA SHOWN. .000050 THICK NICKEL UNDERPLATE ON ENTIRE CONTACT.
- ⑦ CONTACTS PLATED WITH GOLD FLASH ON MATING END FOR .100 MIN LENGTH. .0001-.0002 THICK MATTE TIN PLATE IN AREA SHOWN. .000030 MIN NICKEL UNDERPLATE ON ENTIRE CONTACT.
- ⑧ HOUSING: BLACK THERMOPLASTIC 94V-0 RATED. CONTACTS: PHOSPHOR BRONZE.

SUPD BY 745209-3	③	2	#22-26	745209-8
	⑥	2	#22-26	745209-7
	⑤	3	#20-22	745209-6
		2	#22-26	745209-5
	④	1	#26-30	745209-4
		3	#20-22	745209-3
	④	2	#22-26	745209-2
		1	#26-30	745209-1
FINISH	②	AWG WIRE RANGE	PART NUMBER	

THIS DRAWING IS A CONTROLLED DOCUMENT.		DWN L. VARELA - DOCKS 11-15-04	Tyco Electronics Corporation Harrisburg, PA 17105-3608	
DIMENSIONS: INCHES	TOLERANCES UNLESS OTHERWISE SPECIFIED:	CHK J. GERACE 11-15-04	RECEPTACLE ASSEMBLY, SIZE 3, 25 POSITION, AMPLIMITE	
	0 PLC ± -	APVD M. WALMSLEY 11-15-04	SIZE A2	CAGE CODE 00779
	1 PLC ± -	PRODUCT SPEC 108-40011	DRAWING NO C=745209	RESTRICTED TO -
	2 PLC ± -	APPLICATION SPEC 114-40002	SCALE 4:1	SHEET 1 OF 1
	3 PLC ± .005	WEIGHT -	CUSTOMER DRAWING	REV L
	4 PLC ± - z	FINISH SEE TABLE		
	ANGLES ± z			