

STRAIGHT PLUG CRIMP TYPE

CABLE 2.6/50 S

R141.075.161

Series : **BNC-COM**

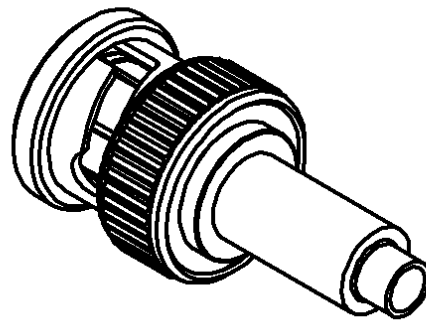
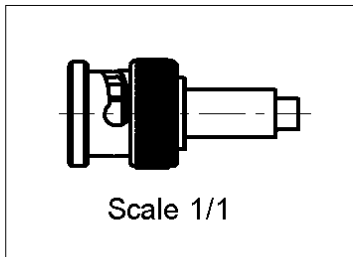
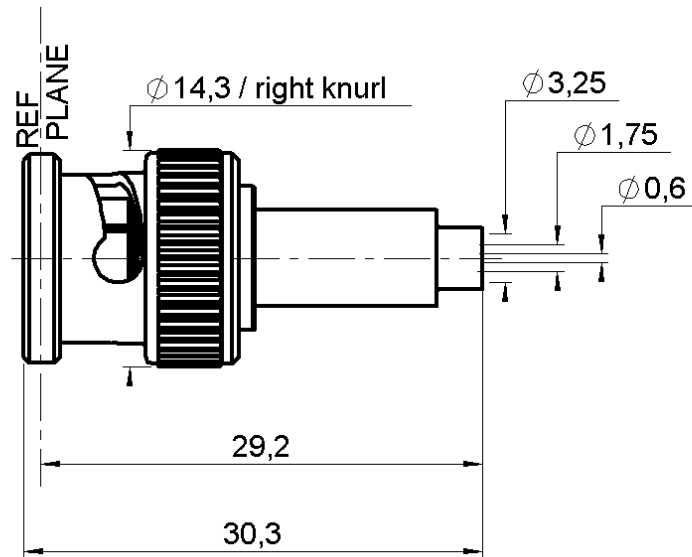

All dimensions are in mm.



COMPONENTS	MATERIALS	PLATINGS (µm)
BODY	BRASS	NICKEL 2
CENTER CONTACT	BRASS	GOLD 0.2 OVER NICKEL 2
OUTER CONTACT	-	-
INSULATOR	PTFE , POLYAMIDE	-
GASKET	SILICONE RUBBER	-
OTHERS PARTS	-	-
-	-	-
-	-	-

Issue : 0325 C

In the effort to improve our products, we reserve the right to make changes judged to be necessary.



STRAIGHT PLUG CRIMP TYPE

R141.075.161

CABLE 2.6/50 S

Series : **BNC-COM**

PACKAGING

Standard	Unit	Other
100	'W' option	Contact us

SPECIFICATION

ELECTRICAL CHARACTERISTICS

Impedance		50	Ω
Frequency		0-1.5	GHz
VSWR	1.8 +	0.000	x F(GHz) Maxi
Insertion loss		0.115	\sqrt{F} (GHz) dB Maxi
RF leakage	- (NA	- F(GHz)) dB Maxi
Voltage rating		500	Veff Maxi
Dielectric withstanding voltage		1500	Veff mini
Insulation resistance		5000	M Ω mini

CABLE ASSEMBLY

Stripping	a	b	c	d	e	f
mm	4.00	10.0	18.5	0.00	14.5	0.00

Assembly instruction : **Crimp 03**

Recommended cable(s)

KX 22A

RG 188

RG 316

Characteristics indicated on this data sheet are those that can be achieved with the highest performance cable. Intrinsic limitations of the cable may diminish the performance of the assembly

Cable retention

- pull off **40** N mini

- torque **NA** N.cm

MECHANICAL CHARACTERISTICS

Center contact retention			
Axial force – Mating end		10	N mini
Axial force – Opposite end		10	N mini
Torque		NA	N.cm mini

TOOLING

Part Number	Description	Hexagon
.	.	.
R282.223.000	CRIMPING TOOL	1.73.5.41
R282.235.011	CRIMPING DIES	1.73.5.41
R282.293.000	CRIMPING TOOL	-

Recommended torque			
Mating		NA	N.cm
Panel nut		NA	N.cm
Clamp nut		NA	N.cm
A/F clamp nut		0.000	mm

Mating life		100	Cycles mini
Weight		8.800	g

OTHERS CHARACTERISTICS

-

ENVIRONMENTAL

Operating temperature		-35/+70	$^{\circ}$ C
Hermetic seal		NA	Atm.cm3/s
Panel leakage		NA	

Issue : 0325 C

In the effort to improve our products, we reserve the right to make changes judged to be necessary.

